

LT8551
Multiphase Boost Converter Expander

DESCRIPTION

Demonstration circuit 2332A-A is a multiphase boost converter expander that features the LT®8551. The DC2332A-A uses the LTC®3769 as primary controller and LT8551 as a phase extender. The increased number of power phases, allowed by the LT8551, results in higher output power without a corresponding increase in design difficulty or a sacrifice of the primary controller LTC3769 features.

The input voltage range of DC2332A-A is from 6V to 46V and the output is 48V. The maximum input current is 10A per power section, so the maximum input current of DC2332A-A is 50A. It can produce a 25A output current and output power of 1,200W with an input voltage of 24V. Correspondingly, output current will drop to 12A and output power to 576W at 12V_{IN}. Higher output power can be achieved at a 12V_{IN} if heat sinks are installed, see Parts List.

The switching frequency is 350kHz and at a 24V_{IN} to a 48V_{OUT} at full load, the efficiency of DC2133A-A is 97.5%. As the input voltage decreases, the output current should be decreased to prevent saturation of the DC2133A-A' inductors, (see the derating curve in Figure 3 and efficiency curves in Figure 4).

The DC2332A-A supports an option to program the phase relationship between the power sections, setting the Total Distinct Phase Number (TDPN). For increased efficiency and reduced switching losses at light loads the DC2332A-A supports disconnecting some power sections or stage shedding, which can be programmed by stage shed jumper JP3. Jumper JP1 programs the LT8551 SYNC pin to allow the DC2332A-A to be synchronized to an external clock.

The DC2332A-A uses jumper JP2 to enable or disable the controller. The SYNC (E19) input can be used to sync the LT8551 with external signal. There are also terminals that make it easy to monitor the control logic between master and slave DC2332's (if used). Removal of jumper resistors can cleanly separate the electrical interface between the LTC3769 primary controller and the remainder of DC2332A-A, making it possible to connect an alternate primary controller in place of the LTC3769. Noise immune signal and ground via pairs are available to reestablish the connections between the DC2332A-A and twisted wire pairs sensing the new primary controller.

The DC2332A-A includes filters and filter options for inputs to the LT8551 in accordance with data sheet recommendations. Under voltage shutdown, switching frequency and LT8551 ILIM current limit levels can all be adjusted by resistors or resistor jumpers. The DC2332A-A comes with a housekeeping circuit that provides an 5.0V input voltage to the LT8551. The housekeeping circuit based on U3 and the LT8631 reduces the power dissipation that would otherwise occur at high input voltages in regulator transistor Q21. The DC2133A-A uses resistors to sense inductor current but can be configured for DCR sensing of inductor current as well.

A high level of available output power without a corresponding high level of design complexity makes the LT8551 attractive for high current DC bus and battery systems in commercial, industrial and automotive settings. The DC2332A-A features the LT8551EUKG in a thermally enhanced 52-pin 7mm × 8mm QFN package. The LT8551 and LTC3769 data sheets must be read in conjunction with this demo manual to properly use or modify DC2332A-A.

[Design files for this circuit board are available.](#)

All registered trademarks and trademarks are the property of their respective owners.

DEMO MANUAL DC2332A-A

PERFORMANCE SUMMARY Specifications are at $T_A = 25^\circ\text{C}$

PARAMETER	CONDITIONS	MIN	TYP	MAX	UNITS
Minimum Input Voltage, V_{IN}				12	V
Maximum Input Voltage, V_{IN}		46			V
Output Voltage, V_{OUT}			48		V
Input current, I_{IN}				50	A
Efficiency	$V_{IN} = 24\text{V}, I_{OUT} = 25\text{A}$		97.5		%
Switching Frequency		350			kHz

QUICK START PROCEDURE

To evaluate the performance of DC2332A-A follow procedure below:

1. Read LT8551 data sheet, conduct visual inspection of DC2332A-A, locating input/output terminals and control jumpers.
2. Prepare to use the SHDN terminal to control the startup: Connect the SHDN terminal to GND by setting jumper JP2 SHDN into OFF position.
3. Set the STAGE SHED MODE jumper JP4 to ENABLE if phase shedding is desired or to DISABLE if phase shedding is not desired.
4. Set the SYNC jumper JP1 to GND.
5. Verify the phase selection resistors.
6. Connect the input power supply with power off, load and meters as shown on Figure 1.
7. Make sure that input power supply is 1,500W and output current at least 60A, the same related to load, it should be at least 1,500W and 60V rating.
8. After connections are made, turn on the input power supply and verify that input voltage between 6V and 46V.
9. Set output load to 0A.

10. Set jumper JP2 SHDN into ON position, you should observe 48V on the output terminals and the load.

11. Once the proper output voltage is established, adjust the load and observe the output voltage regulation, ripple voltage, efficiency and other parameters.

NOTE: If the output voltage is low, try startup again using SHDN with the load disconnected. The load may cause low output if some of the DC2332A power sections are inadvertently disconnected and not able to deliver power. It is possible the input supply may current limit and cause DC2332A to have low output. In more extreme cases it is possible that the load may be set too high for DC2332A.

The DC2332A-A supports the multi-chip (master-slave) feature of the LT8551 so the total number of power sections can be increased in four power section increments: The DC2133A-A (master) and future, under development, DC2133A-B (slave), use the same PCB. Please use notation [2] in the electrical schematic for assembling slave group of phases. DC2332A-A is designed so it is easy to add power sections and increase output power. The master and slave assemblies are programmed using jumpers and adjustment of regulation loop compensation is usually not necessary as power sections are added. The control signal interface between master and slave assemblies is a common ribbon cable.

QUICK START PROCEDURE

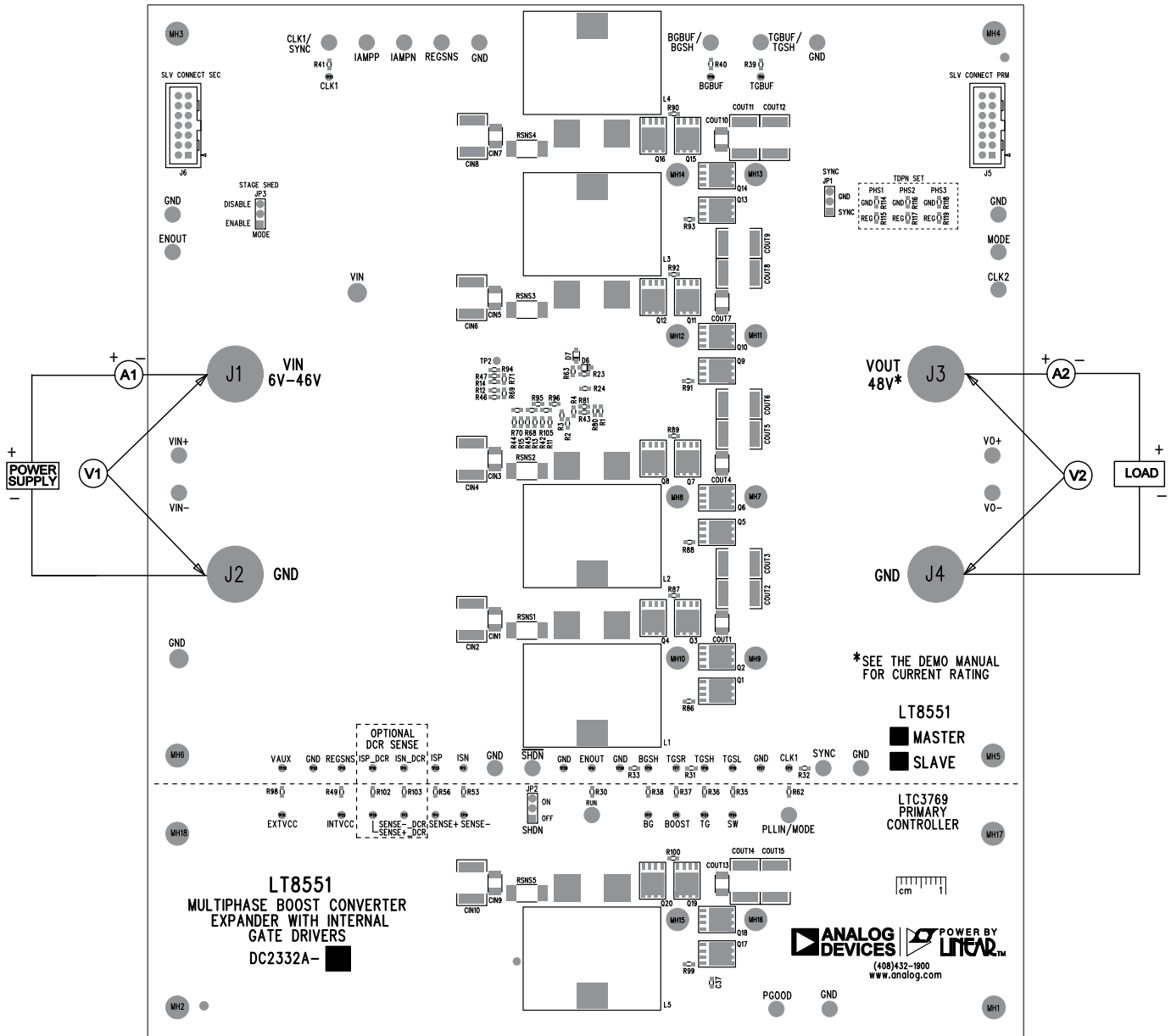

Figure 1. Proper Equipment Setup for DC2332A-A

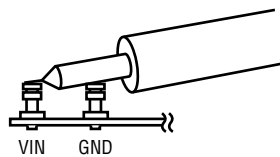

Figure 2. Measuring Input or Output Ripple

QUICK START PROCEDURE

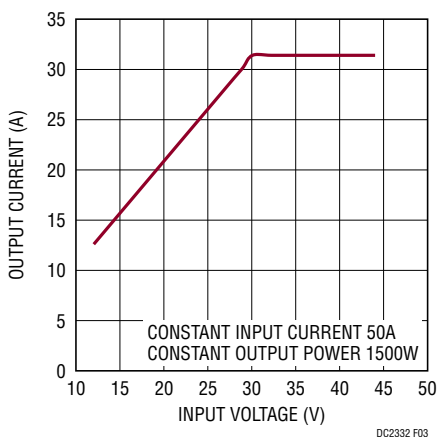

Figure 3. Derating Guidelines, Output Current vs Input Voltage

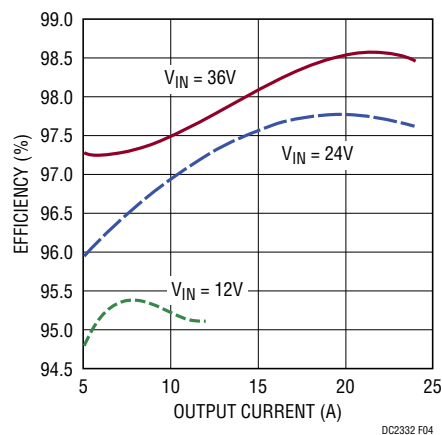

Figure 4. Efficiency vs Output Current and Input Voltage, V_{OUT} is 48V

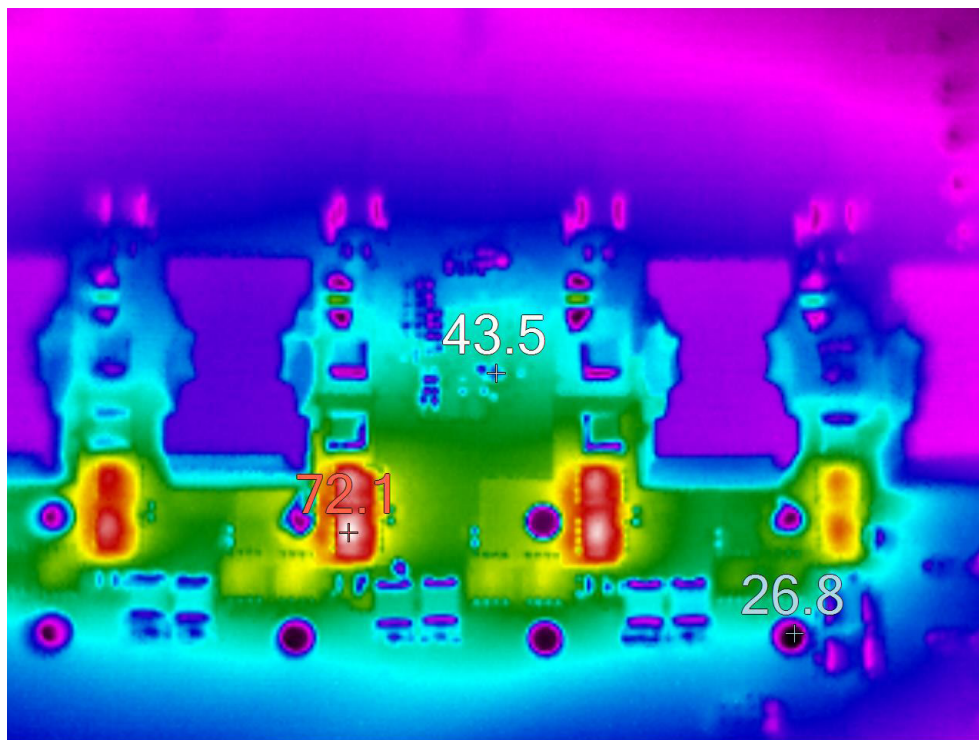

Figure 5. Thermal Map of Four Phases of LT8551 Multiphase Boost Converter Expander ($V_{IN} = 24.0V$, $V_{OUT} = 48.0V$, $I_{OUT} = 25A$, $T_{MAX} = 72.1^{\circ}C$), $T_A = 25^{\circ}C$ without Cooling Fan

PARTS LIST

ITEM	QTY	REFERENCE	PART DESCRIPTION	MANUFACTURER/PART NUMBER
Required Circuit Components				
1	4	CIN1, CIN3, CIN5, CIN7	CAP., X7R, 10µF, 50V, 10%, 1210	MURATA, GRM32ER71H106KA12L
2	1	CIN9	CAP., X7R, 10µF, 50V, 10%, 1210	MURATA, GRM32ER71H106KA12L
3	12	CIN2, CIN4, CIN6, CIN8, COUT2, COUT3, COUT5, COUT6, COUT8, COUT9, COUT11, COUT12	CAP., X7R, 15µF, 100V, 20%, 2220	TDK, CGA9P3X7S2A156M250
4	4	COUT1, COUT4, COUT7, COUT10	CAP., X7S, 4.7µF, 100V, 10%, 1210	MURATA, GRJ32DC72A475KE11L
5	3	CIN10, COUT14, COUT15	CAP., X7R, 15µF, 100V, 20%, 2220	MURATA, KRM55WR72A156MH01K
6	1	COUT13	CAP., X7S, 4.7µF, 100V, 10%, 1210	MURATA, GRJ32DC72A475KE11L
7	1	C1	CAP., X7R, 1µF, 50V, 10%, 1206	MURATA, GRM31CR71H105KA61L
8	2	C2, C33	CAP., X5R, 2.2µF, 16V, 10%, 0603	MURATA, GRM188R61C225KE15D
9	1	C3	CAP., X5R, 10µF, 16V, 10%, 0603	MURATA, GRM188R61C106KAALD
10	10	C4, C7, C8, C9, C10, C11, C12, C13, C35, C55	CAP., X7R, 1nF, 25V, 10%, 0603	MURATA, GRM188R71E102KA01D
11	3	C5, C15, C30	CAP., X7R, 1nF, 25V, 10%, 0603	MURATA, GRM188R71E102KA01D
12	1	C6	CAP., X7R, 100pF, 16V, 10%, 0603	AVX, 0603YC101KAT2A
13	1	C16	CAP., ALUM., 10µF, 100V, 20%	SUN ELEC., 100CE10BS
14	4	C17, C18, C19, C20	CAP., X7R, 0.22µF, 16V, 10%, 0603	MURATA, GRM188R71C224KA01D
15	3	C21, C27, C34	CAP., X7R, 0.1µF, 50V, 10%, 0603	MURATA, GRM188R71H104KA93D
16	1	C22	CAP., X7R, 0.22µF, 16V, 10%, 0603	MURATA, GRM188R71C224KA01D
17	1	C23	CAP., X7R, 1µF, 50V, 10%, 1206	MURATA, GRM31CR71H105KA61L
18	1	C24	CAP., X7R, 1µF, 16V, 10%, 0603	MURATA, GRM188R71C105KA12D
19	1	C25	CAP., X5R, 1µF, 25V, 10%, 0603	AVX, 06033D105KAT2A
20	1	C26	CAP., NP0, 4.7pF, 50V, ±0.25pF, 0603	MURATA, GRM1885C1H4R7CA01D
21	1	C28	CAP., X7R, 2.2µF, 100V, 10%, 1210	MURATA, GRM32ER72A225KA35L
22	1	C29	CAP., X7R, 4.7µF, 16V, 10%, 0805	MURATA, GRM21BR71C475KA73L
23	1	C31	CAP., 0.015µF, 10V, U2J, 0603	MURATA, GRM1887U1A153JA01D
24	1	C32	CAP., X5R, 47µF, 16V, 10%, 1210	MURATA, GRM32ER61C476KE15K
25	2	C36, C57	CAP., X7R, 0.01µF, 16V, 10%, 0603	MURATA, GRM188R71C103KA01D
26	1	C37	CAP., X7R, 0.1µF, 50V, 10%, 0603	MURATA, GRM188R71H104KA93D
27	1	C58	CAP., NP0, 22pF, 50V, 5%, 0603	MURATA, GRM1885C1H220JA01D
28	2	C60, C61	CAP., ALUM., 100µF, 100V, 20%	SUN ELEC., 100CE100BST+D
29	2	C62, C63	CAP., ALUM., 1000µF, 50V, 20%	PANASONIC, EEEFK1H102AM
30	4	D1, D2, D3, D4	DIODE, SCHOTTKY, 70V, SOD323	INFINEON, BAS170WE6327HTSA1
31	1	D5	DIODE, SCHOTTKY, 70V, SOD323	INFINEON, BAS170WE6327HTSA1
32	2	D6, D7	DIODE, SCHOTTKY, 100V, SOD323	NEXPERIA, BAT46WJ,115
33	1	D8	DIODE, 1N4448HWT, SOD523	DIODES INC., 1N4448HWT-7
34	4	L1, L2, L3, L4	IND., 10µH	COILCRAFT, SER2918H-103KL
35	1	L5	IND., 10µH	COILCRAFT, SER2918H-103KL
36	1	L6	IND., 22µH	WURTH ELEKTRONIK, 7447779122

DEMO MANUAL DC2332A-A

PARTS LIST

ITEM	QTY	REFERENCE	PART DESCRIPTION	MANUFACTURER/PART NUMBER
37	20	Q1, Q2, Q3, Q4, Q5, Q6, Q7, Q8, Q9, Q10, Q11, Q12, Q13, Q14, Q15, Q16, Q17, Q18, Q19, Q20	XSTR., MOSFET, 60V, PG-TDSON-8	INFINEON, BSC100N06LS3GATMA1
38	1	Q21	MOSFET, P-CH 100V 2.6A SOT223	DIODES INC., ZXMP10A18G
39	5	RSNS1, RSNS2, RSNS3, RSNS4, RSNS5	RES., SENSE, 0.004Ω, 3W, 1%, 2512	PANASONIC, ERJ-MS4SF4M0U
40	1	R1	RES., 71.5k, 1/10W, 1%, 0603	VISHAY, CRCW060371K5FKEA
41	1	R2	RES., 100k, 1/10W, 1%, 0603	VISHAY, CRCW0603100K0FKEA
42	1	R3	RES., 21.5k, 1/10W, 1%, 0603	VISHAY, CRCW060321K5FKEA
43	3	R4, R9, R16	RES., 47k, 1/10W, 5%, 0603	VISHAY, CRCW060347K0JNEA
44	7	R7, R11, R12, R13, R14, R15, R24	RES., 10Ω, 1/10W, 5%, 0603	VISHAY, CRCW060310R0JNEA
45	1	R8	RES., CHIP, 20Ω, 1/10W, 5%, 0603	VISHAY, CRCW060320R0JNEA
46	1	R10	RES., 1Ω, 1/10W, 5%, 0603	VISHAY, CRCW06031R00JNEA
47	1	R17	RES., 12.1k, 1/10W, 1%, 0603	VISHAY, CRCW060312K1FKEA
48	1	R18	RES., 464k, 1/10W, 1%, 0603	VISHAY, CRCW0603464KFKEA
49	1	R19	RES., 7.87k, 1/10W, 1%, 0603	VISHAY, CRCW06037K87FKEA
50	1	R20	RES., 10k, 1/10W, 5%, 0603	VISHAY, CRCW060310K0JNEA
51	3	R21, R25, R34	RES., 10Ω, 1/10W, 5%, 0603	VISHAY, CRCW060310R0JNEA
52	1	R26	RES., 10k, 1/10W, 5%, 0603	VISHAY, CRCW060310K0JNEA
53	1	R27	RES., 25.5k, 1/10W, 1%, 0603	VISHAY, CRCW060325K5FKEA
54	1	R28	RES., 162k, 1/10W, 1%, 0603	VISHAY, CRCW0603162KFKEA
55	2	R29, R61	RES., 1M, 1/10W, 1%, 0603	VISHAY, CRCW06031M00FKEA
56	1	U1	I.C., LT8551, 52QFN	ANALOG DEVICES, LT8551EUKG#PBF
57	1	U2	I.C., REG BOOST CONTROLLER, 24QFN	ANALOG DEVICES, LTC3769EUF#PBF
58	1	U3	I.C., REG., TSSOP28FE-EA	ANALOG DEVICES, LT8631EFE#PBF

Additional Demo Board Circuit Components

1	0	C14, C38, C39, C40, C41, C42, C43, C44, C45, C46, C47, C48, C49, C50, C51, C52, C53, C54, C56(OPT)	CAP, OPTION, 0603	
2	21	E1, E2, E3, E4, E5, E6, E7, E8, E9, E10, E11, E12, E13, E14, E15, E16, E17, E19, E21, E22, E23, E24, E25, E26, E27	TESTPOINT, TURRET, 0.061"	MILL-MAX, 2308-2-00-80-00-00-07-0
3	2	E28, E29	TESTPOINT, TURRET, 0.094"	MILL-MAX, 2501-2-00-80-00-00-07-0
4	3	JP1, JP2, JP3	HEADER 3-PIN 0.079" SINGLE ROW	WURTH ELEKTRONIK, 62000311121
5	2	XJP1, XJP3	SHUNT, 2mm	WURTH ELEKTRONIK, 60800213421
6	1	XJP2	SHUNT, 2mm, GOLD	SULLINS CONNECTOR, NPN02SXLN-RC
7	4	J1-J4	STUD, TEST PIN	PEM, KFH-032-10ET
8	8	(J1-J4)	NUT, BRASS NUTS # 10-32	ANY, 10-32M/S BR PL
9	12	(J1-J4)	RING, LUG RING # 10	KEYSTONE, 8208
10	4	(J1-J4)	WASHER, TIN PLATED BRASS	ANY, #10EXT- BZ TN
11	0	J5, J6	HEADER, 2X7PIN, 0.079"	MOLEX, 87831-1420

PARTS LIST

ITEM	QTY	REFERENCE	PART DESCRIPTION	MANUFACTURER/PART NUMBER
12	29	R5, R6, R22, R23, R30, R35, R36, R37, R38, R39, R40, R41, R49, R53, R56, R62, R82, R89, R90, R91, R92, R93, R99, R100, R101, R112, R115, R117, R118	RES., 0Ω, 1/10W, 1%, 0603	VISHAY, CRCW06030000Z0EA
13	0	R31, R32, R33, R42, R43, R44, R45, R46, R47, R50, R51, R52, R54, R55, R57, R58, R59, R60, R63, R64, R65, R66, R67, R68, R69, R70, R71, R76, R77, R78, R79, R80, R81, R84, R85, R86, R87, R88, R94, R95, R96, R97, R98, R102, R103, R104, R105, R111, R113, R114, R116, R119, R120	RES., OPTION, 0603	
14	0	R72, R73, R74, R75 (OPT)	RES., OPTION, 0805	
15	0	R83 (OPT)	RES., OPTION, 0805	
16		HS1, HS2, HS3, HS4, HS5 (5)	OPT., HEATSINK, 67605 SERIES, 24mm × 15.04mm	OPT., AAVID THERMALLOY, 676053B01969G
17		WASHER (10)	OPT., WASHER SHOULDER #4 NYLON	OPT., KEYSTONE ELECTRONICS, 3049
18		THERMAL PAD (5)	OPT., THERMAL INTERFACE PRODUCTS SIL PAD 400	OPT., BERGQUIST COMPANY, SP400-0.007

Hardware

1	21	E1, E2, E3, E4, E5, E6, E7, E8, E9, E10, E11, E12, E14, E15, E16, E19, E21, E22, E23, E24, E27	TESTPOINT, TURRET, 0.061"	MILL-MAX, 2308-2-00-80-00-00-07-0
2	2	E28, E29	TESTPOINT, TURRET, 0.094"	MILL-MAX, 2501-2-00-80-00-00-07-0
3	3	JP1, JP2, JP3	HEADER 3-PIN 0.079" SINGLE ROW	WURTH ELEKTRONIK, 62000311121
4	5	XJP1, XJP2, XJP3, XJP4, XJP5	SHUNT, 2mm	WURTH ELEKTRONIK, 60800213421
5	4	J1-J4	STUD, TEST PIN	PEM, KFH-032-10ET
6	8	(J1-J4)	NUT, BRASS NUTS # 10-32	ANY, 10-32M/S BR PL
7	12	(J1-J4)	RING, LUG RING # 10	KEYSTONE, 8208
8	4	(J1-J4)	WASHER, TIN PLATED BRASS	ANY, #10EXT- BZ TN
9	4	MH1-MH4	STAND-OFF, NYLON 1.0	WURTH ELEKTRONIK, 702939000
10		J5, J6	HEADER, 2X7PIN, 0.079"	MOLEX, 87831-1420

SCHEMATIC DIAGRAM

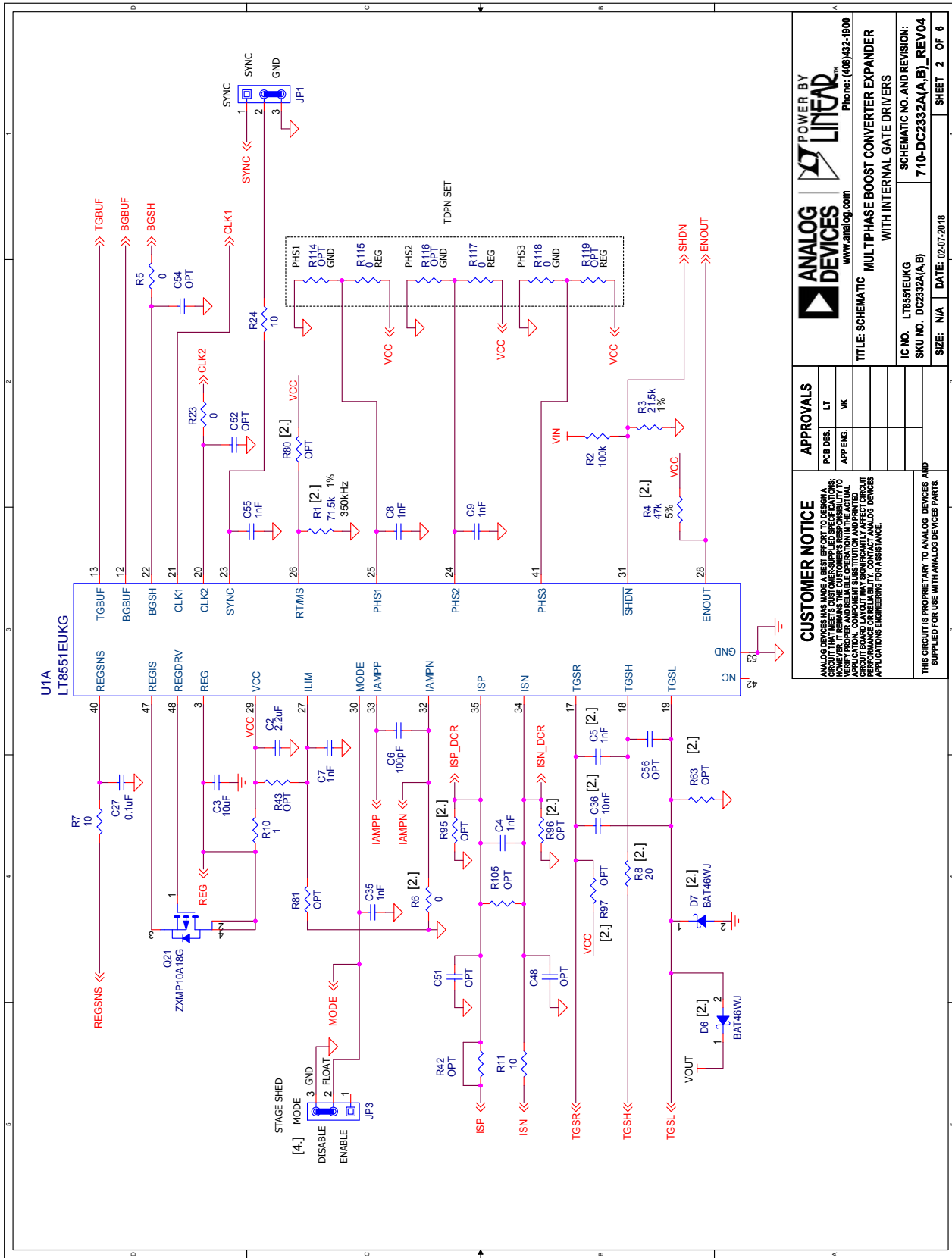

CUSTOMER NOTICE		APPROVALS	
<p>ANY CHANGES TO THIS SCHEMATIC MUST BE APPROVED BY AN ANALOG DEVICES APPLICATION ENGINEER. THE CUSTOMER IS RESPONSIBLE FOR THE PROPER APPLICATION OF THIS SCHEMATIC TO THEIR OWN BOARD LAYOUT. ANY CHANGES TO THIS SCHEMATIC MUST BE APPROVED BY AN ANALOG DEVICES APPLICATION ENGINEER FOR ASSISTANCE.</p>		<p>PCB DES. LT</p> <p>APP. ENG. VK</p>	<p>IC NO. LT8551EUKG</p> <p>SKU NO. DC2332A(A,B)</p> <p>SIZE: N/A</p>
<p>THIS CIRCUIT IS PROPRIETARY TO ANALOG DEVICES AND SUPPLIED FOR USE WITH ANALOG DEVICES PARTS.</p>		<p>POWER BY</p> <p>ANALOG DEVICES</p> <p>www.analog.com</p>	<p>PHONE: (609)432-1900</p> <p>SCHEMATIC NO. AND REVISION:</p> <p>710-DC2332A(A,B)_REV04</p> <p>DATE: 02-07-2018</p> <p>SHEET 2 OF 6</p>

DEMO MANUAL DC2332A-A

SCHEMATIC DIAGRAM

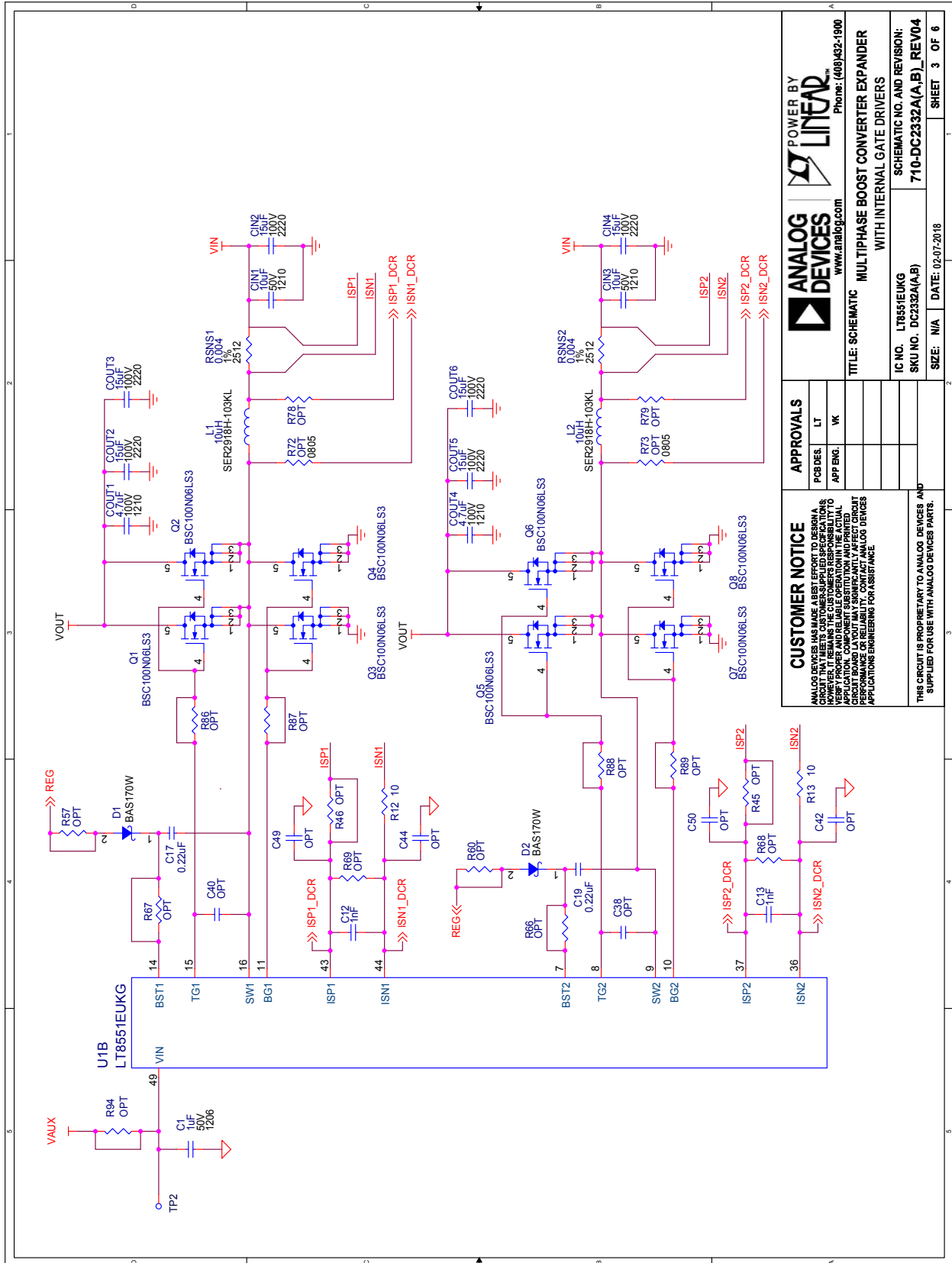

www.analog.com		Phone: (408)432-1900	
TITLE: SCHEMATIC MULTIPHASE BOOST CONVERTER EXPANDER WITH INTERNAL GATE DRIVERS		SCHEMATIC NO. AND REVISION: 710-DC2332A(A,B)_REV04	
IC NO.: LT8551EUKG		DATE: 02-07-2018	
SKU NO.: DC2332A(A,B)		SHEET: 3 OF 6	
SIZE: N/A		DATE: 02-07-2018	
APPROVALS		CUSTOMER NOTICE	
PCB DES.	LT	ANALOG DEVICES HAS MADE A BEST EFFORT TO DESIGN, DEVELOP, MANUFACTURE, TEST, AND DELIVER THIS SCHEMATIC. HOWEVER, IT REMAINS THE CUSTOMER'S RESPONSIBILITY TO VERIFY PROPER AND RELIABLE OPERATION IN THE ACTUAL APPLICATION. THE CUSTOMER MUST VERIFY THAT THE SCHEMATIC PERFORMANCE OR RELIABILITY, CONTACT ANALOG DEVICES APPLICATIONS ENGINEERING FOR ASSISTANCE.	
APP ENG.	YK		
THIS CIRCUIT IS PROPRIETARY TO ANALOG DEVICES AND SUPPLIED FOR USE WITH ANALOG DEVICES PARTS.			

SCHEMATIC DIAGRAM

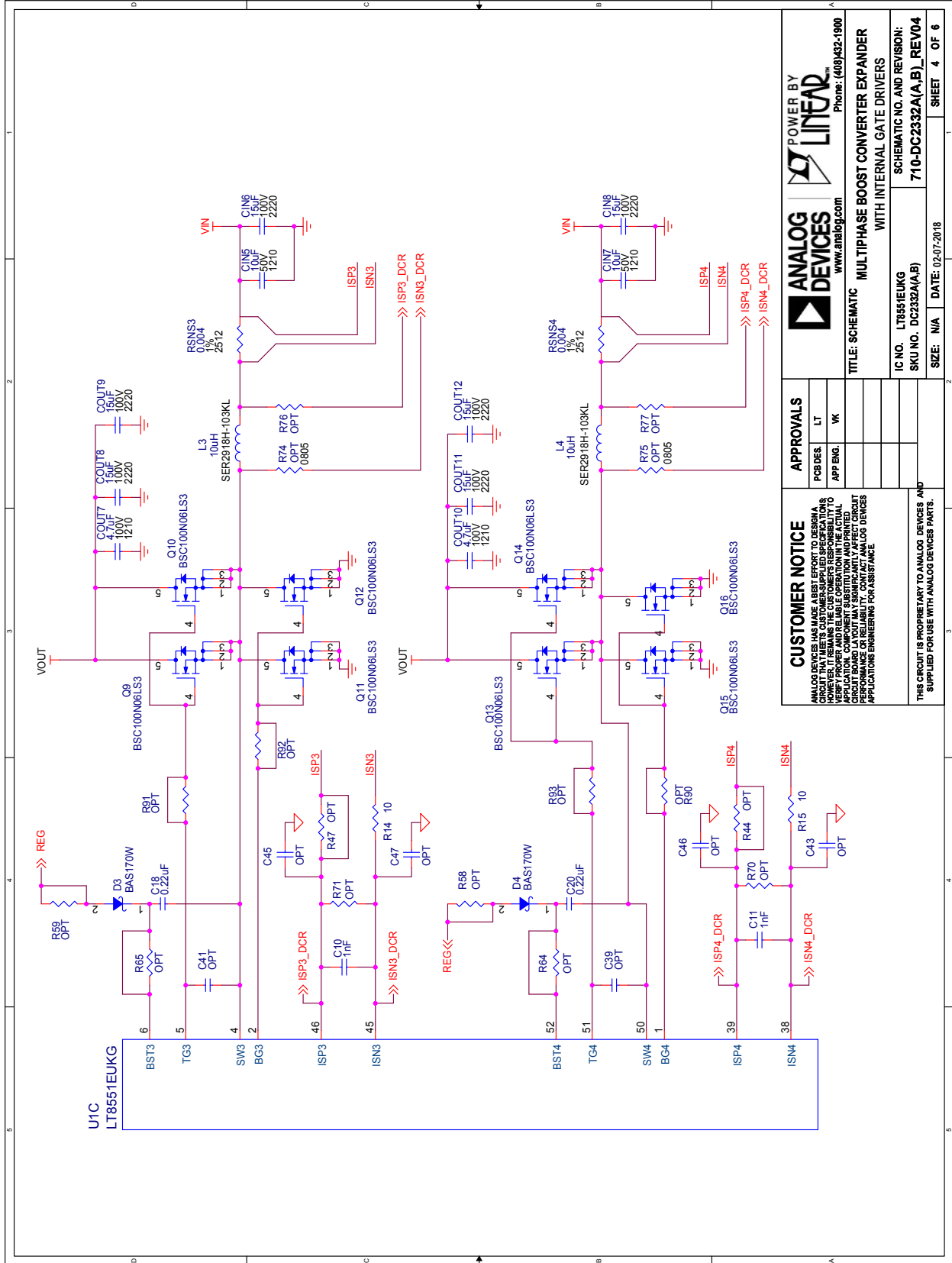

www.analog.com		Phone: (408)432-1900	
TITLE: SCHEMATIC MULTIPHASE BOOST CONVERTER EXPANDER WITH INTERNAL GATE DRIVERS			
IC NO. LT8551EUKG		SCHEMATIC NO. AND REVISION:	
SKU NO. DC2332A(A,B)		710-DC2332A(A,B)_REV04	
SIZE: N/A		DATE: 02-07-2018	
SHEET 4 OF 6			
APPROVALS			
PCB DES.	LT		
APP ENG.	YK		
CUSTOMER NOTICE			
ANALOG DEVICES HAS MADE A BEST EFFORT TO DESIGN A SCHEMATIC THAT REPRESENTS THE INTENDED FUNCTION OF THE IC. HOWEVER, IT REMAINS THE CUSTOMER'S RESPONSIBILITY TO VERIFY PROPER AND RELIABLE OPERATION IN THE ACTUAL APPLICATION. THE SCHEMATIC IS PROVIDED AS A GUIDE ONLY. PERFORMANCE OR RELIABILITY MAY VARY SIGNIFICANTLY AFFECT CIRCUIT APPLICATIONS ENGINEERING FOR ASSISTANCE.			
THIS CIRCUIT IS PROPRIETARY TO ANALOG DEVICES AND SUPPLIED FOR USE WITH ANALOG DEVICES PARTS.			

DEMO MANUAL DC2332A-A

SCHEMATIC DIAGRAM

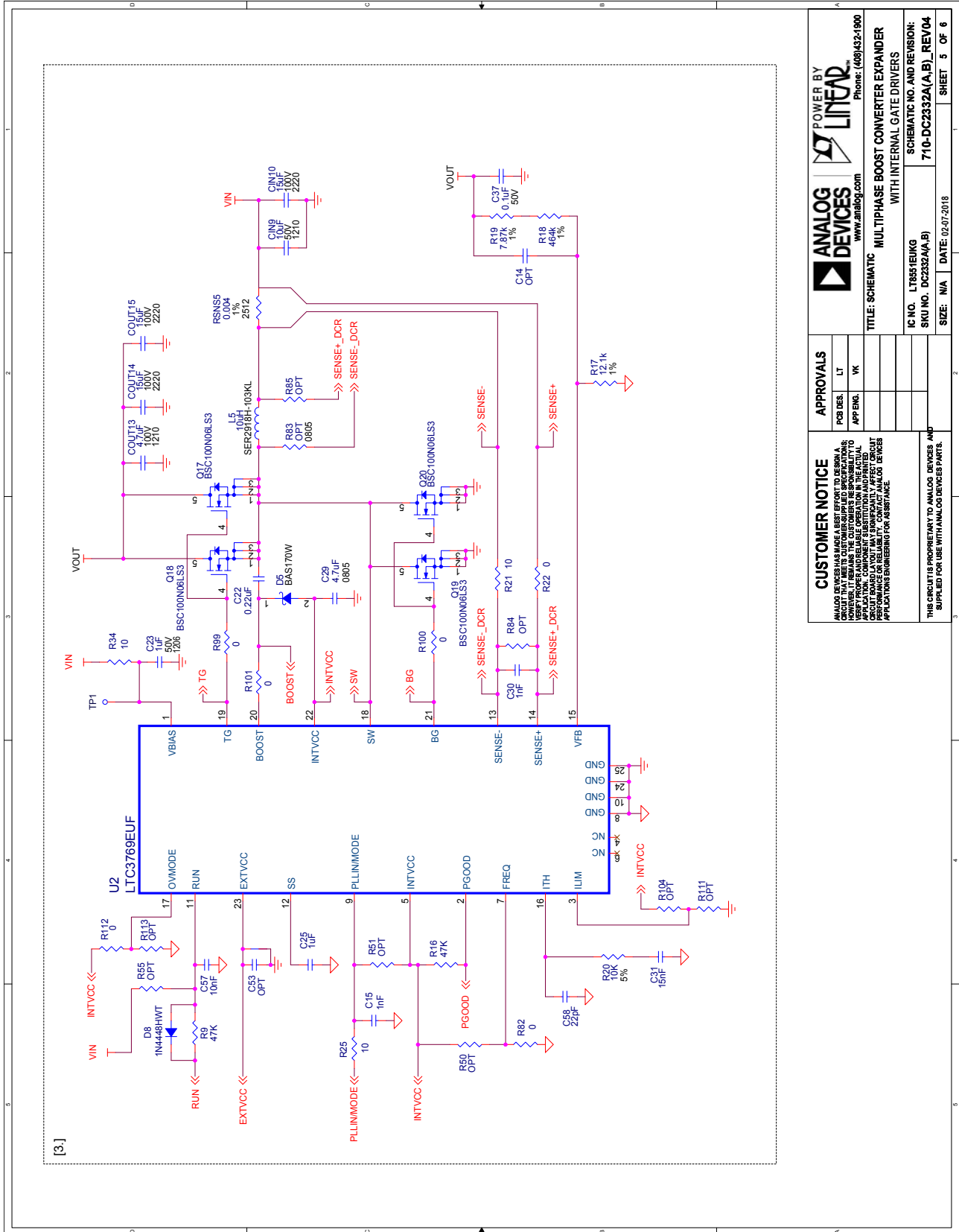

POWER BY
LINEAR
 Phone: (408)321-9800
 www.analog.com

ANALOG DEVICES
 www.analog.com

APPROVALS

POB RES.	LT
APP ENG.	VK

CUSTOMER NOTICE
 ANALOG DEVICES HAS MADE A BEST EFFORT TO DESIGN A CIRCUIT THAT MEETS CUSTOMER-SUPPLIED SPECIFICATIONS AND TO PROVIDE A REASONABLE LEVEL OF PERFORMANCE. WE DO NOT WARRANT OR REPRESENT THAT THE ACTUAL PERFORMANCE OR RELIABILITY OF ANY INDIVIDUAL CIRCUIT BOARD LAYOUT WILL SIGNIFICANTLY AFFECT CIRCUIT APPLICATIONS OR REDESIGN FOR ASSISTANCE.

IC NO. L18851EUKG
SKU NO. DC2332A(A,B)
SIZE: N/A **DATE: 02-07-2018**

TITLE: SCHEMATIC MULTIPHASE BOOST CONVERTER EXPANDER WITH INTERNAL GATE DRIVERS
SCHEMATIC NO. AND REVISION: 710-DC2332A(A,B)_REV04
SHEET 5 OF 6

CUSTOMER NOTICE
 ANALOG DEVICES HAS MADE A BEST EFFORT TO DESIGN A CIRCUIT THAT MEETS CUSTOMER-SUPPLIED SPECIFICATIONS AND TO PROVIDE A REASONABLE LEVEL OF PERFORMANCE. WE DO NOT WARRANT OR REPRESENT THAT THE ACTUAL PERFORMANCE OR RELIABILITY OF ANY INDIVIDUAL CIRCUIT BOARD LAYOUT WILL SIGNIFICANTLY AFFECT CIRCUIT APPLICATIONS OR REDESIGN FOR ASSISTANCE.

THIS CIRCUIT IS PROPRIETARY TO ANALOG DEVICES AND SUPPLIED FOR USE WITH ANALOG DEVICES PARTS.

SCHEMATIC DIAGRAM

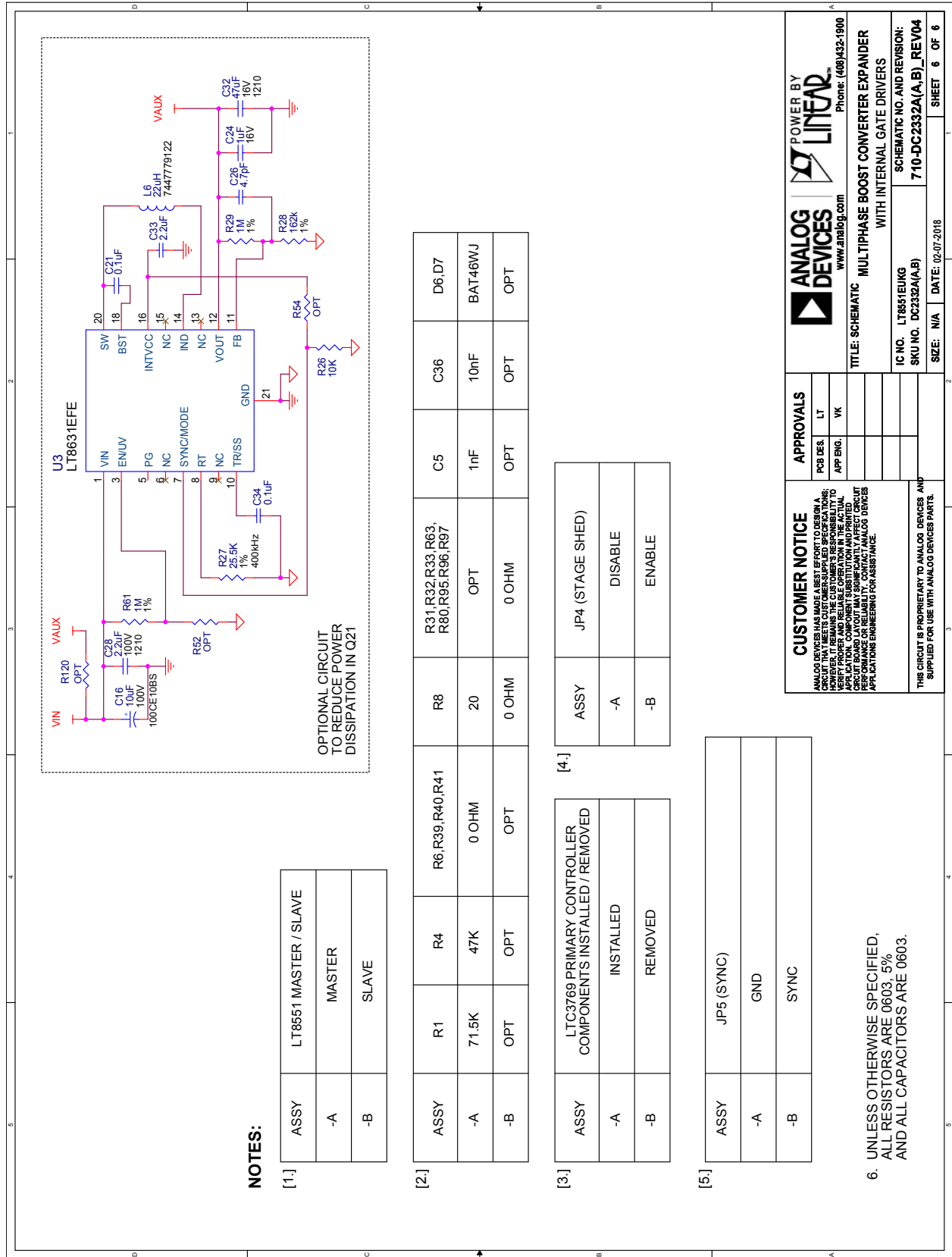

NOTES:

[1.]	ASSY	LT8651 MASTER / SLAVE
	-A	MASTER
	-B	SLAVE

[2.]	ASSY	R1	R4	R6, R39, R40, R41	R8	R31, R32, R33, R63, R80, R95, R96, R97	C5	C36	D6, D7
	-A	71.5K	47K	0 OHM	20	OPT	1nF	10nF	BAT46WJ
	-B	OPT	OPT	OPT	0 OHM	0 OHM	OPT	OPT	OPT

[3.]	ASSY	LTC3769 PRIMARY CONTROLLER COMPONENTS INSTALLED / REMOVED
	-A	INSTALLED
	-B	REMOVED

[5.]	ASSY	JP5 (SYNC)
	-A	GND
	-B	SYNC

6. UNLESS OTHERWISE SPECIFIED, ALL RESISTORS ARE 0603, 5% AND ALL CAPACITORS ARE 0603.

		POWER BY www.analog.com	TITLE: SCHEMATIC MULTIPHASE BOOST CONVERTER EXPANDER WITH INTERNAL GATE DRIVERS	IC NO. LT8651EUJG SKU NO. DC2332A(A,B)	SCHEMATIC NO. AND REVISION: 710-DC2332A(A,B)_REV04
CUSTOMER NOTICE ANALOG DEVICES HAS MADE A BEST EFFORT TO DESIGN A CIRCUIT THAT MEETS CUSTOMER-SUPPLIED SPECIFICATIONS. CUSTOMERS ARE RESPONSIBLE FOR VERIFYING THE PERFORMANCE OF THE ACTUAL APPLICATION. COMPONENT SUBSTITUTION AND PRINTED CIRCUIT BOARD MANUFACTURING VARIATIONS MAY AFFECT PERFORMANCE OR RELIABILITY. CONTACT ANALOG DEVICES APPLICATIONS ENGINEERING FOR ASSISTANCE.			APPROVALS PCB DES: LT APP ENG: VK		
THIS CIRCUIT IS PROPRIETARY TO ANALOG DEVICES AND SUPPLIED FOR USE WITH ANALOG DEVICES PARTS.			DATE: 02-07-2018 SHEET 6 OF 6		



ESD Caution

ESD (electrostatic discharge) sensitive device. Charged devices and circuit boards can discharge without detection. Although this product features patented or proprietary protection circuitry, damage may occur on devices subjected to high energy ESD. Therefore, proper ESD precautions should be taken to avoid performance degradation or loss of functionality.

Legal Terms and Conditions

By using the evaluation board discussed herein (together with any tools, components documentation or support materials, the "Evaluation Board"), you are agreeing to be bound by the terms and conditions set forth below ("Agreement") unless you have purchased the Evaluation Board, in which case the Analog Devices Standard Terms and Conditions of Sale shall govern. Do not use the Evaluation Board until you have read and agreed to the Agreement. Your use of the Evaluation Board shall signify your acceptance of the Agreement. This Agreement is made by and between you ("Customer") and Analog Devices, Inc. ("ADI"), with its principal place of business at One Technology Way, Norwood, MA 02062, USA. Subject to the terms and conditions of the Agreement, ADI hereby grants to Customer a free, limited, personal, temporary, non-exclusive, non-sublicensable, non-transferable license to use the Evaluation Board FOR EVALUATION PURPOSES ONLY. Customer understands and agrees that the Evaluation Board is provided for the sole and exclusive purpose referenced above, and agrees not to use the Evaluation Board for any other purpose. Furthermore, the license granted is expressly made subject to the following additional limitations: Customer shall not (i) rent, lease, display, sell, transfer, assign, sublicense, or distribute the Evaluation Board; and (ii) permit any Third Party to access the Evaluation Board. As used herein, the term "Third Party" includes any entity other than ADI, Customer, their employees, affiliates and in-house consultants. The Evaluation Board is NOT sold to Customer; all rights not expressly granted herein, including ownership of the Evaluation Board, are reserved by ADI. CONFIDENTIALITY. This Agreement and the Evaluation Board shall all be considered the confidential and proprietary information of ADI. Customer may not disclose or transfer any portion of the Evaluation Board to any other party for any reason. Upon discontinuation of use of the Evaluation Board or termination of this Agreement, Customer agrees to promptly return the Evaluation Board to ADI. ADDITIONAL RESTRICTIONS. Customer may not disassemble, decompile or reverse engineer chips on the Evaluation Board. Customer shall inform ADI of any occurred damages or any modifications or alterations it makes to the Evaluation Board, including but not limited to soldering or any other activity that affects the material content of the Evaluation Board. Modifications to the Evaluation Board must comply with applicable law, including but not limited to the RoHS Directive. TERMINATION. ADI may terminate this Agreement at any time upon giving written notice to Customer. Customer agrees to return to ADI the Evaluation Board at that time. LIMITATION OF LIABILITY. THE EVALUATION BOARD PROVIDED HEREUNDER IS PROVIDED "AS IS" AND ADI MAKES NO WARRANTIES OR REPRESENTATIONS OF ANY KIND WITH RESPECT TO IT. ADI SPECIFICALLY DISCLAIMS ANY REPRESENTATIONS, ENDORSEMENTS, GUARANTEES, OR WARRANTIES, EXPRESS OR IMPLIED, RELATED TO THE EVALUATION BOARD INCLUDING, BUT NOT LIMITED TO, THE IMPLIED WARRANTY OF MERCHANTABILITY, TITLE, FITNESS FOR A PARTICULAR PURPOSE OR NON-INFRINGEMENT OF INTELLECTUAL PROPERTY RIGHTS. IN NO EVENT WILL ADI AND ITS LICENSORS BE LIABLE FOR ANY INCIDENTAL, SPECIAL, INDIRECT, OR CONSEQUENTIAL DAMAGES RESULTING FROM CUSTOMER'S POSSESSION OR USE OF THE EVALUATION BOARD, INCLUDING BUT NOT LIMITED TO LOST PROFITS, DELAY COSTS, LABOR COSTS OR LOSS OF GOODWILL. ADI'S TOTAL LIABILITY FROM ANY AND ALL CAUSES SHALL BE LIMITED TO THE AMOUNT OF ONE HUNDRED US DOLLARS (\$100.00). EXPORT. Customer agrees that it will not directly or indirectly export the Evaluation Board to another country, and that it will comply with all applicable United States federal laws and regulations relating to exports. GOVERNING LAW. This Agreement shall be governed by and construed in accordance with the substantive laws of the Commonwealth of Massachusetts (excluding conflict of law rules). Any legal action regarding this Agreement will be heard in the state or federal courts having jurisdiction in Suffolk County, Massachusetts, and Customer hereby submits to the personal jurisdiction and venue of such courts. The United Nations Convention on Contracts for the International Sale of Goods shall not apply to this Agreement and is expressly disclaimed.