

Signal Chain Power Series LT8618 Inverting Regulator

DESCRIPTION

Demonstration circuit SCP-LT8618-IEVALZ is a high efficiency 65V, 100mA synchronous step-down regulator configured as an inverting buck topology for positive to negative DC voltage conversion.

Like all boards in the Signal Chain Power series, this board is designed to be easily plugged into other SCP boards to form a complete signal chain power system, enabling fast evaluation of low power signal chains. To evaluate this board, some universal SCP hardware is required, namely:

- SCP-INPUT-EVALZ SCP-1X2BKOUT-EVALZ
- SCP-OUTPUT-EVALZ SCP-1X5BKOUT-EVALZ
- SCP-FILTER-EVALZ SCP-5X1-EVALZ
- SCP-THRUBRD-EVALZ

To properly evaluate SCP series demo boards, you will need the SCP Configurator companion software. SCP Configurator can help you choose the right board and topology for your design.

Note that this Demo Manual does not cover details important to the operation and configuration regarding the [LT8618](#). Please refer to the [LT8618 datasheet](#) for a complete description of the part.

Design files for this circuit board are available.

All registered trademarks and trademarks are property of their respective owners.

Table 1. Performance Summary

SYMBOL	PARAMETER	NOTES	MIN	TYP	MAX	UNITS
V _{IN(MAX)}	Max Input Voltage				60	V
V _{OUT(MAX)}	Max Output Voltage				-48	V
I _{SW(LIM)}	Switch Current Limit		150	200	250	mA

BOARD IMAGE

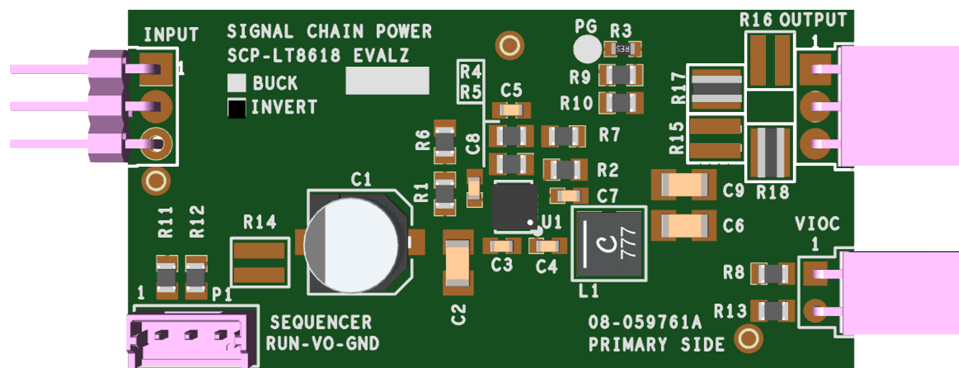

Figure 1. SCP-LT8618-IEVALZ Evaluation Board

QUICK START PROCEDURE

Demonstration circuit SCP-LT8618-IEVALZ is easy to set up to evaluate the performance of any SCP hardware configuration.

1. The SCP-LT8618-IEVALZ ships with a default output voltage of $-5V$. To change the output voltage, see “Configuration Settings” section, and modify the board accordingly. Be sure to check for open connections or solder shorts after making any modifications.
2. Connect the SCP-INPUT-EVALZ and SCP-OUTPUT-EVALZ boards to the SCP-LT8618-IEVALZ (refer to Figure 2) and connect the input board to a voltage source, V_{SOURCE} . Connect the output board to a voltmeter or dynamic load. Slowly raise the input voltage until the SCP-LT8618-IEVALZ powers up into regulation and sweep V_{SOURCE} through the desired range of operation.

NOTE: Make sure that the input voltage is always within spec. If using a dynamic load to measure output voltage, make sure the load is initially set to zero.

3. Check for proper output voltage. The output should be regulated at the programmed value ($\pm 5\%$).
4. Once the proper output voltage is established, power off V_{SOURCE} and similarly test other boards in the SCP system until all elements have been individually verified prior to assembling into the final circuit configuration.

NOTE: When measuring the input or output voltage ripple, use the optional SMA connector locations available on the input, output, 1×5 , 1×2 , and 5×1 breakout boards. Avoid using the test point connections with long scope leads.

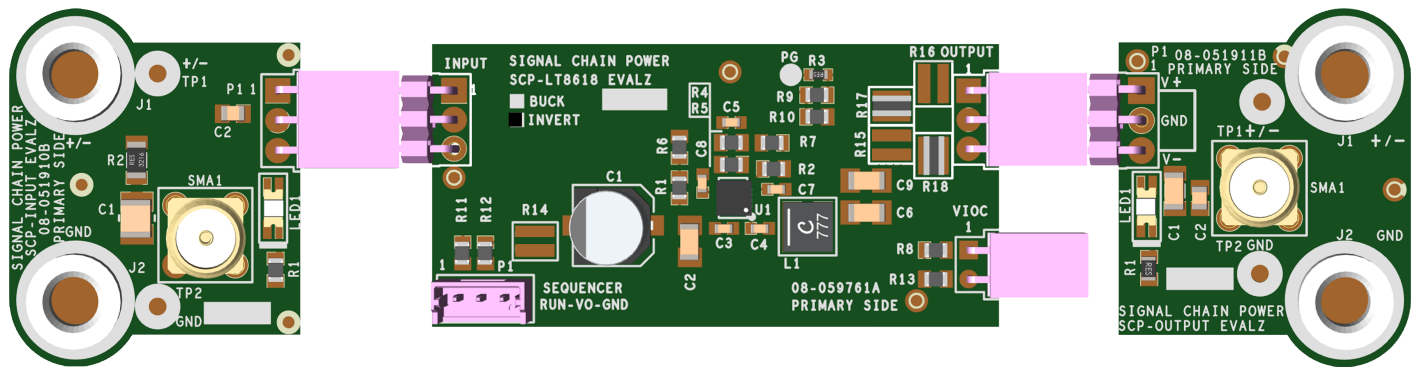

Figure 2. Proper Measurement Equipment Setup (Use SMA connectors for Measuring Input or Output Ripple)

CONFIGURATION SETTINGS

Demonstration circuit SCP-LT8618-IEVALZ is a high efficiency 65V, 100mA synchronous step-down regulator configured as an inverting buck topology for positive to negative DC voltage conversion.

The output of the SCP-LT8618-IEVALZ is resistor-programmable from $-0.8V$ to $-48V$.

OUTPUT VOLTAGE PROGRAMMING

$$|V_{OUT}| = 0.778V \left(1 + \frac{R4}{R5} \right)$$

Table 2. Resistor Selection Guide for Common Output Voltages

V _{OUT} (V)	R4 (Ω)	R5 (Ω)
-0.8	3.24k	115k
-0.9	3.83k	137k
-1.0	102k	357k
-1.1	42.2k	102k
-1.2	102k	187k
-1.25	162k	267k
-1.5	205k	221k
-1.8	1.00M	768k
-2.0	1.15M	732k
-2.5	1.47M	665k
-3.0	1.02M	357k
-3.3	590k	182k
-3.5	357k	102k
-4.0	422k	102k
-4.5	511k	107k
-5.0	1.02M	187k
-5.5	698k	115k
-6.0	1.13M	169k
-6.5	787k	107k
-7.0	1.50M	187k
-7.5	1.27M	147k
-8.0	1.30M	140k
-12.0	1.47M	102k
-16.0	1.50M	76.8k
-20.0	1.50M	60.4k
-24.0	1.50M	49.9k
-30.0	1.50M	40.2k
-36.0	1.50M	33.2k
-42.0	1.50M	28.0k
-48.0	1.50M	24.9k

EN/UV PIN CONFIGURATION

The EN/UV pin is tied to the optional SCP Run/Sequence header P1. To create a harness for this function, use Molex part 0510650300 with crimp pin 50212-8000.

To use an active run signal, use a $1.00M\Omega$ resistor for either pull-up or pull-down resistors R1 and R6, short R11 with 0Ω , and use the drive signal from connector P1.

If precision UVLO operation is desired, program enable divider R1 and R6 such that:

R6 is 10k to 100k, nominal

$$R1 = R6 \left(\frac{V_{IN} - 1.05V}{1.05V} \right)$$

The LT8618 has an accurate 1.05V threshold which places the part into under voltage lockout. The hysteresis threshold on the rising edge is typically 50mV and scales by the factor:

$$V_{HYST} = 50mV \frac{R1 + R6}{R6}$$

VOLTAGE INPUT-TO-OUTPUT CONTROL (VIOC) IMPLEMENTATION

VIOC cannot be implemented with the board in the inverting buck configuration. If using a VIOC-capable negative linear regulator, ensure R8 and R13 are open and independently set fixed output voltages for both the SCP-LT8618-IEVALZ board and the negative linear regulator board.

DEMO MANUAL SCP-LT8618-IEVALZ

FREQUENCY PIN CONFIGURATION

The LT8618 allows the user to program an operating frequency by a single resistor. The default operating frequency is 2.0MHz. Note that changing the switching frequency may affect other parameters and likely necessitates a change in inductor and compensation component values. Contact the SCP team for applications support if shifting the switching frequency greater than $\pm 10\%$.

Table 3. Resistor Selection Guide for Switching Frequency Setting

f_{sw}	R2 (Ω)	f_{sw}	R2 (Ω)
200kHz	221k	1.30MHz	30.1k
300kHz	143k	1.40MHz	27.4k
400kHz	110k	1.50MHz	25.5k
500kHz	86.6k	1.60MHz	23.7k
600kHz	71.5k	1.70MHz	22.1k
700kHz	60.4k	1.80MHz	20.5k
800kHz	52.3k	1.90MHz	19.1k
900kHz	46.4k	2.00MHz	18.2k
1.00MHz	40.2k	2.10MHz	16.9k
1.10MHz	36.5k	2.20MHz	16.2k
1.20MHz	33.2k		

DEMO MANUAL SCP-LT8618-IEVALZ

PARTS LIST

ITEM	QTY	REFERENCE	PART DESCRIPTION	MANUFACTURER/PART NUMBER
1	1	PCB	PCB	ANALOG DEVICES 08_059761a
2	1	C1	CAP 22uF 63V ALUM 8x10.5	SUN ELECTRONIC 63CE22BSA
3	1	C2	CAP 1uF 100V CER, X7R 1206	TAIYO YUDEN HMK316B7105KL-T
4	1	C3	CAP 0.1uF 100V CER X7R 0603	SAMSUNG CL10B104KC8NNNC
5	1	C4	CAP 47nF 50V CER X7R 0603	KEMET C0603X473K5RACTU
6	1	C5	CAP MLCC 0603 (Note 1)	N/A
7	1	C6	CAP 10uF 50V X5R 1206	SAMSUNG CL31A106MBHNNNE
8	1	C7	CAP 1uF 10V X7R 0603	SAMSUNG CL10B105KP8NNNC
9	1	C8	CAP 10nF 50V CER X7R 0603	YAGEO CC0603KRX7R9BB103
10	1	C9	CAP 4.7uF 50V CER X7R 1206	SAMSUNG CL31B475KBHNNNE
11	1	INPUT	CONN MALE 3POS 2.54MM PITCH R/A	SULLINS PBC03SBAN
12	1	L1	IND 33uH 0.42A 0.66OHM	WURTH ELEKTRONIK 44031330
13	1	OUTPUT	CONN FEMALE 3POS 2.54MM PITCH R/A	SULLINS PPPC031LGBN-RC
14	1	P1	CONN-PCB 3POS HEADER WIRE TO BRD WAFER ASSY STRAIGHT 2MM PITCH (Note 1)	MOLEX 53253-0370
15	1	R1	RES 1M 1%THICK FILM 0805	YAGEO RC0805JR-071ML
16	6	R6, R8, R10, R11, R12, R13	RES THICK FILM 0805 (Note 1)	N/A
17	3	R14, R15, R16	RES 0 OHM 1% 3/4W 0612	VISHAY RCL06120000Z0EA
18	2	R17, R18	RES THICK FILM 0612 (Note 1)	N/A
19	1	R2	RES 18.2K 1% THICK FILM 0805	PANASONIC ERJ-6ENF1822V
20	1	R3	RES 49.9K 1% THICK FILM 0805	PANASONIC ERJ-3EKF4992V
21	1	R4	RES 1M 1% THICK FILM 0805	PANASONIC ERJ-6ENF1004V
22	1	R5	RES 187K 1% THICK FILM 0805	PANASONIC ERJ-6ENF1873V
23	2	R7, R9	RES 0-OHM 1%THICK FILM 0805	VISHAY CRCW08050000Z0EA
24	1	U1	IC-ADI HIGH EFFICIENCY SYNCHRONOUS BUCK	ANALOG DEVICES LT8618EDDB#PBF
25	1	VIOC	CONN FEMALE 2POS 2.54MM PITCH R/A	SULLINS PPPC021LGBN-RC

Note 1. These items are not stuffed (DNI).

DEMO MANUAL SCP-LT8618-IEVALZ



ESD Caution

ESD (electrostatic discharge) sensitive device. Charged devices and circuit boards can discharge without detection. Although this product features patented or proprietary protection circuitry, damage may occur on devices subjected to high energy ESD. Therefore, proper ESD precautions should be taken to avoid performance degradation or loss of functionality.

Legal Terms and Conditions

By using the evaluation board discussed herein (together with any tools, components documentation or support materials, the "Evaluation Board"), you are agreeing to be bound by the terms and conditions set forth below ("Agreement") unless you have purchased the Evaluation Board, in which case the Analog Devices Standard Terms and Conditions of Sale shall govern. Do not use the Evaluation Board until you have read and agreed to the Agreement. Your use of the Evaluation Board shall signify your acceptance of the Agreement. This Agreement is made by and between you ("Customer") and Analog Devices, Inc. ("ADI"), with its principal place of business at One Technology Way, Norwood, MA 02062, USA. Subject to the terms and conditions of the Agreement, ADI hereby grants to Customer a free, limited, personal, temporary, non-exclusive, non-sublicensable, non-transferable license to use the Evaluation Board FOR EVALUATION PURPOSES ONLY. Customer understands and agrees that the Evaluation Board is provided for the sole and exclusive purpose referenced above, and agrees not to use the Evaluation Board for any other purpose. Furthermore, the license granted is expressly made subject to the following additional limitations: Customer shall not (i) rent, lease, display, sell, transfer, assign, sublicense, or distribute the Evaluation Board; and (ii) permit any Third Party to access the Evaluation Board. As used herein, the term "Third Party" includes any entity other than ADI, Customer, their employees, affiliates and in-house consultants. The Evaluation Board is NOT sold to Customer; all rights not expressly granted herein, including ownership of the Evaluation Board, are reserved by ADI. CONFIDENTIALITY. This Agreement and the Evaluation Board shall all be considered the confidential and proprietary information of ADI. Customer may not disclose or transfer any portion of the Evaluation Board to any other party for any reason. Upon discontinuation of use of the Evaluation Board or termination of this Agreement, Customer agrees to promptly return the Evaluation Board to ADI. ADDITIONAL RESTRICTIONS. Customer may not disassemble, decompile or reverse engineer chips on the Evaluation Board. Customer shall inform ADI of any occurred damages or any modifications or alterations it makes to the Evaluation Board, including but not limited to soldering or any other activity that affects the material content of the Evaluation Board. Modifications to the Evaluation Board must comply with applicable law, including but not limited to the RoHS Directive. TERMINATION. ADI may terminate this Agreement at any time upon giving written notice to Customer. Customer agrees to return to ADI the Evaluation Board at that time. LIMITATION OF LIABILITY. THE EVALUATION BOARD PROVIDED HEREUNDER IS PROVIDED "AS IS" AND ADI MAKES NO WARRANTIES OR REPRESENTATIONS OF ANY KIND WITH RESPECT TO IT. ADI SPECIFICALLY DISCLAIMS ANY REPRESENTATIONS, ENDORSEMENTS, GUARANTEES, OR WARRANTIES, EXPRESS OR IMPLIED, RELATED TO THE EVALUATION BOARD INCLUDING, BUT NOT LIMITED TO, THE IMPLIED WARRANTY OF MERCHANTABILITY, TITLE, FITNESS FOR A PARTICULAR PURPOSE OR NON-INFRINGEMENT OF INTELLECTUAL PROPERTY RIGHTS. IN NO EVENT WILL ADI AND ITS LICENSORS BE LIABLE FOR ANY INCIDENTAL, SPECIAL, INDIRECT OR CONSEQUENTIAL DAMAGES RESULTING FROM CUSTOMER'S POSSESSION OR USE OF THE EVALUATION BOARD, INCLUDING BUT NOT LIMITED TO LOST PROFITS, DELAY COSTS, LABOR COSTS OR LOSS OF GOODWILL. ADI'S TOTAL LIABILITY FROM ANY AND ALL CAUSES SHALL BE LIMITED TO THE AMOUNT OF ONE HUNDRED US DOLLARS (\$100.00). EXPORT. Customer agrees that it will not directly or indirectly export the Evaluation Board to another country, and that it will comply with all applicable United States federal laws and regulations relating to exports. GOVERNING LAW. This Agreement shall be governed by and construed in accordance with the substantive laws of the Commonwealth of Massachusetts (excluding conflict of law rules). Any legal action regarding this Agreement will be heard in the state or federal courts having jurisdiction in Suffolk County, Massachusetts, and Customer hereby submits to the personal jurisdiction and venue of such courts. The United Nations Convention on Contracts for the International Sale of Goods shall not apply to this Agreement and is expressly disclaimed.