

USER MANUAL

TITLE	Industrial Monitor / Monitor		
MODEL NAME	IDS31-320W		
SERIAL NAME	IDS31-320WC35DVA1E		
Signature	Date	Prepared by	Date
_____	_____		
_____	_____		
_____	_____		
Please return 1 copy for our confirmation with your signature and comments			

TABLE OF CONTENTS

NO	ITEM	PAGE
I	Overview	3
II	General Description	4
III	Electrical Specifications	5-8
1	Electrical Characteristics	
2	Interface Connections	
IV	OSD Function	9
V	Environment Specifications	10
VI	Reliability	
VII	Visual Inspection Standard	11-13
VIII	Accessory	12~18
IX	Mechanical Characteristics	19
X	Packing	20

BSMI 甲類

警告使用者這是甲類資訊產品, 在居住的環境中使用時, 可能會造成射頻干擾, 在這種情況下, 使用者會被要求採取某些適當的對策.

警告: 使用過度恐傷害視力

(1) 使用30分鐘請休息10分鐘。

(2) 2歲以下幼兒不看螢幕, 2歲以上每天看螢幕不要超過1小時。

I . OVERVIEW

The IDS31-320WC35DVA1E is designed 32.0 inch monitor

- Support the monitor with 1920 × 1080 resolution.
- Brightness - 350 cd/m² (without Touch)
- Contrast Ratio : 3000:1

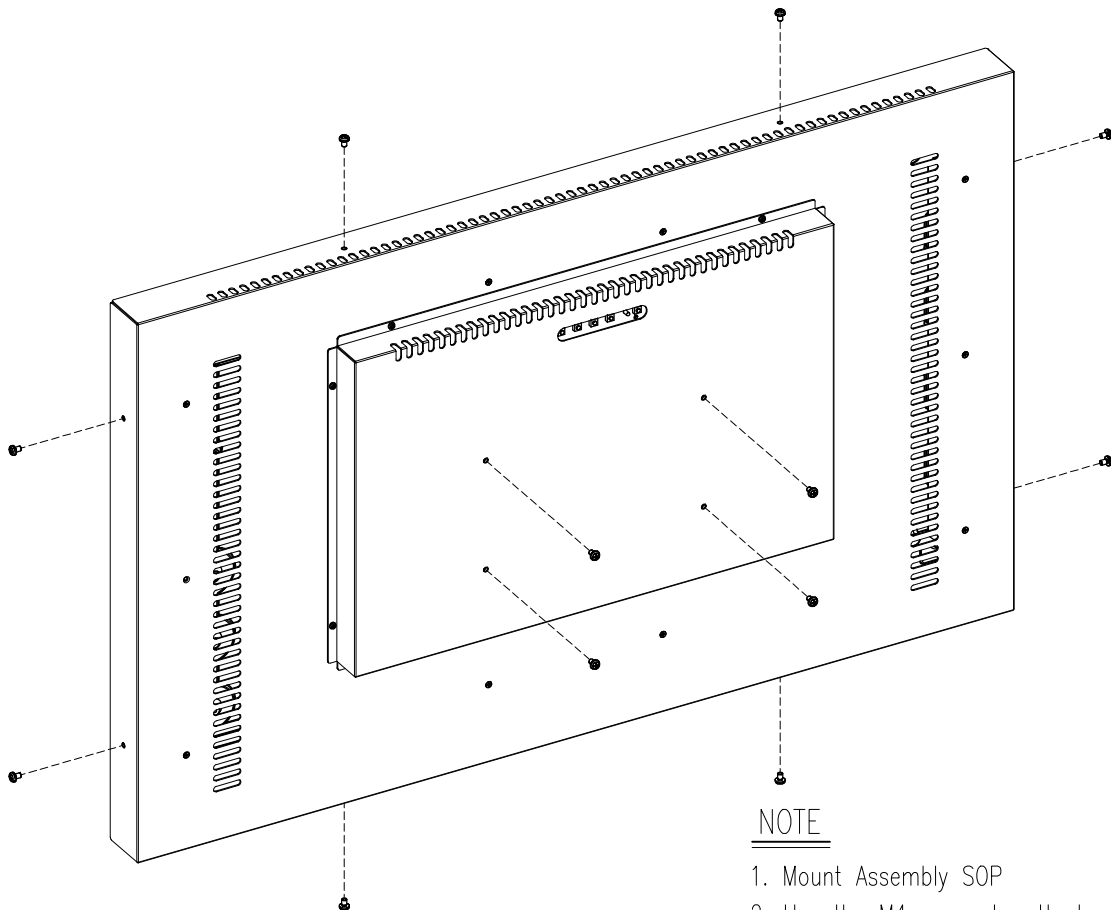
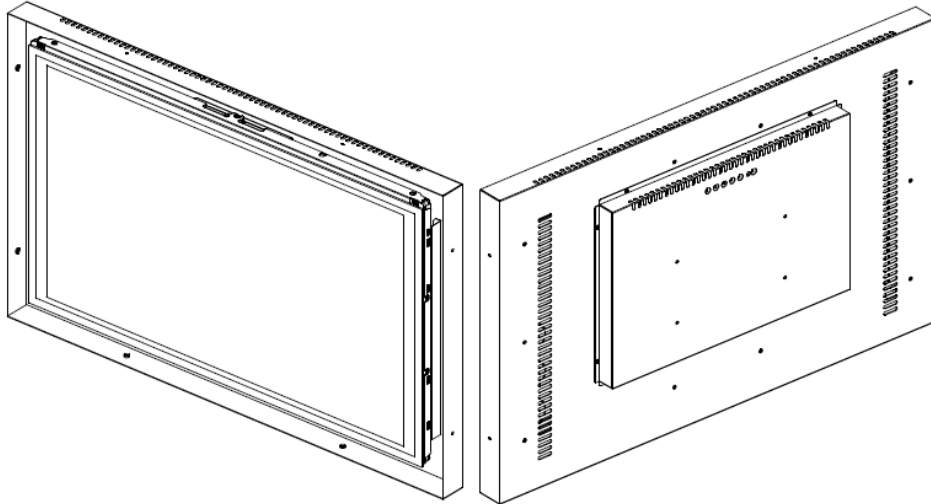

NOTE

1. Mount Assembly SOP
2. Use the M4 screw to attach and tighten as follows.

II . General Description

Display Type	TFT LCD Panel (32.0 inch) - P320HVN01.0_AUO	
Pixel Pitch	0.3637(H)mm X 0.3637(V)mm	
Pixel Format	1920 Hor. By 1080 Ver. Pixels RGB vertical stripe	
Display Colors	16.7M colors	
Brightness	350 cd/m ² (Typical)	
Contrast Ratio	3000 : 1 (Typical)	
Response Time	8 ms (G to G)	
Viewing Angle	Horizontal	178 °
	Vertical	178 °
Life Time	50,000 Hr (Typical)	
Input Signal	Analog RGB, DVI-D	
OSD Controls	Soft Power(On/Off), Menu, Select, Up, Down	
Power Saving (LED Display)	VESA DPMS, On (Green), Stand-By (Green blinking), Suspend (Green blinking), Off	
Dimension	805.0(H) x 495.0(V) x 73.0(D)	
Weight	13.0 kg	
Operating Temp.	0°C ~+50°C	
Storage Temp.	-20°C ~ +60°C	

III. Electrical Specifications

1-1. Electrical Characteristics

Power	DC Input Voltage		24V _{DC} / 5.0A ± 10%	
	Standby power		2.0 W	
	Power consumption		48 W	
Analog	Video Signal	Type	Analog RGB	
		Gain Level	0.714 ± 5%	
		Input impedance	75ohm ± 5%(terminated)	
		Pixel frequency	Max. 165MHz	
		Resolution	Max. 1920×1080 / 60Hz	
	Input Sync Signal	Type	H/V, Separate only	
		Gain Level	TTL level (High ≥ 2.0V, Low ≤ 0.8V)	
		Polarity	Positive or Negative	
		Maximum Duty	Max. 25%	
		Frequency Range	Horizontal	31.43 ~ 88.8KHz,
Vertical	56.25 ~ 75.03Hz			
DVI	Differential output		150 ~ 1200 mVp-p	
	Input clock freq		20 ~ 135 MHz	

1-2 Board Block Diagram

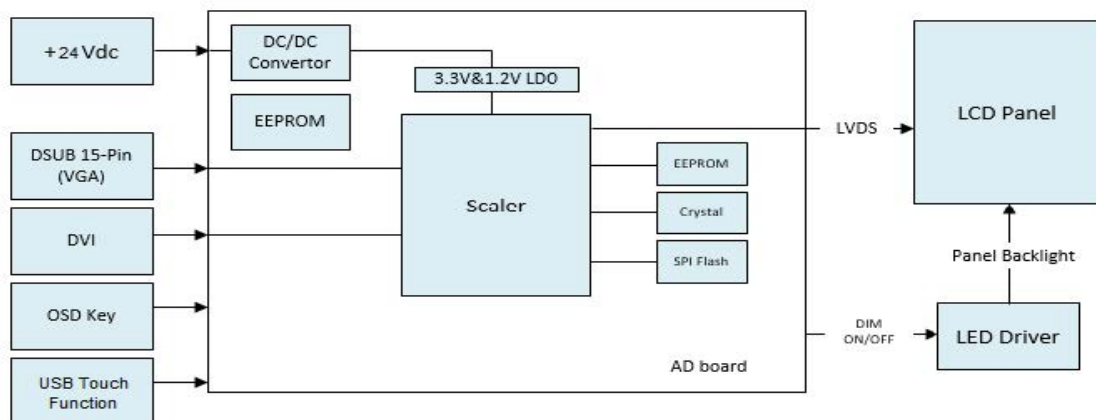

2. I/O Port (Interface Connections)

2-1. Analog RGB Pin Assignment

Connector	P/No.	Symbol	Description
VGA Input connector For 15P D-sub	1	Red	Red, analog input
	2	Green	Green, analog input
	3	Blue	Blue, analog input
	4	N.C	Not connected
	5	DGND	Digital ground
	6	Red GND	Ground for Red return
	7	Green GND	Ground for Green return
	8	Blue GND	Ground for Blue return
	9	N.C	Not connected
	10	DGND	Detect connector
	11	N.C	Not connected
	12	DDC Data	DDC Data
	13	H-sync	Horizontal sync, input
	14	V-sync	Vertical sync, input
	15	DDC Clk	DDC Clk

2-2. DVI Jack Pin Assignment

Connector	P/No.	Symbol	Description
DVI	1	RX2N	TMDS Data 2-
	2	RX2P	TMDS Data 2+
	3	GND	TMDS Data 2/4 Shield
	4	NC	TMDS Data 4-
	5	NC	TMDS Data 4+
	6	SCL-DVI-1	DDC Clock
	7	SDA-DVI-1	DDC Data
	8	VSYNC	Analog Vertical Sync
	9	RX1N	TMDS Data 1-
	10	RX1P	TMDS Data 1+
	11	GND	TMDS Data 1/3 Shield
	12	NC	TMDS Data 3-
	13	NC	TMDS Data 3+
	14	+5V Power	DVI+5V
	15	GND	Ground
	16	HPD	Hot Plug Detect
	17	RX0N	TMDS Data 0-
	18	RX0P	TMDS Data 0+

	19	GND	TMDS Data 0/5 Shield
	20	NC	TMDS Data 5-
	21	NC	TMDS Data 5+
	22	GND	TMDS Clock Shield
	23	RXCP	TMDS Clock +
	24	RXCN	TMDS Clock -
	C1	NC	Analog Red
	C2	NC	Analog Green
	C3	NC	Analog Blue
	C4	HSYNC	Analog Horizontal Sync

2-3. Input Signal format

Character Mode	Pixel Freq. MHz	Horizontal Timing				Vertical Timing			
		Sync Polar	Freq. KHz	Total Pixel	Active Pixel	Sync Polar	Freq. Hz	Total Line	Active Line
640x480 @60Hz	25.175	-	31.47	800	640	-	59.94	525	480
800x600 @60Hz	40.000	-	37.88	1056	800	-	60.32	628	600
1024x768 @60Hz	65.000	-	48.36	1344	1024	-	60.00	806	768
1680x1050@60Hz	119.000	-	64.72	1840	1680	-	60.02	1080	1050
1920x1080@60Hz	148.500	-	66.60	2160	1920	-	60.00	1235	1080

Sync : H/V Separated LVDS

2-4. Touch Glass / Touch Controller

Surface Capacitive Touch (W1-31832APA-G0_Dano Touch)	
Input Method	Finger
Light Transmittance	92 ± 3% per ASTM D1003
Thickness	2.8 mm ±10% typical (glass only, not including tape, wires and solder if used)
Haze(AG)	≤7%
Gloss R'60 (AG type)	110±20 GU
Operating Temperature	-40°C ~ 85°C (Sensor Only)
Storage Temperature	-40°C ~ 85°C (Sensor Only)

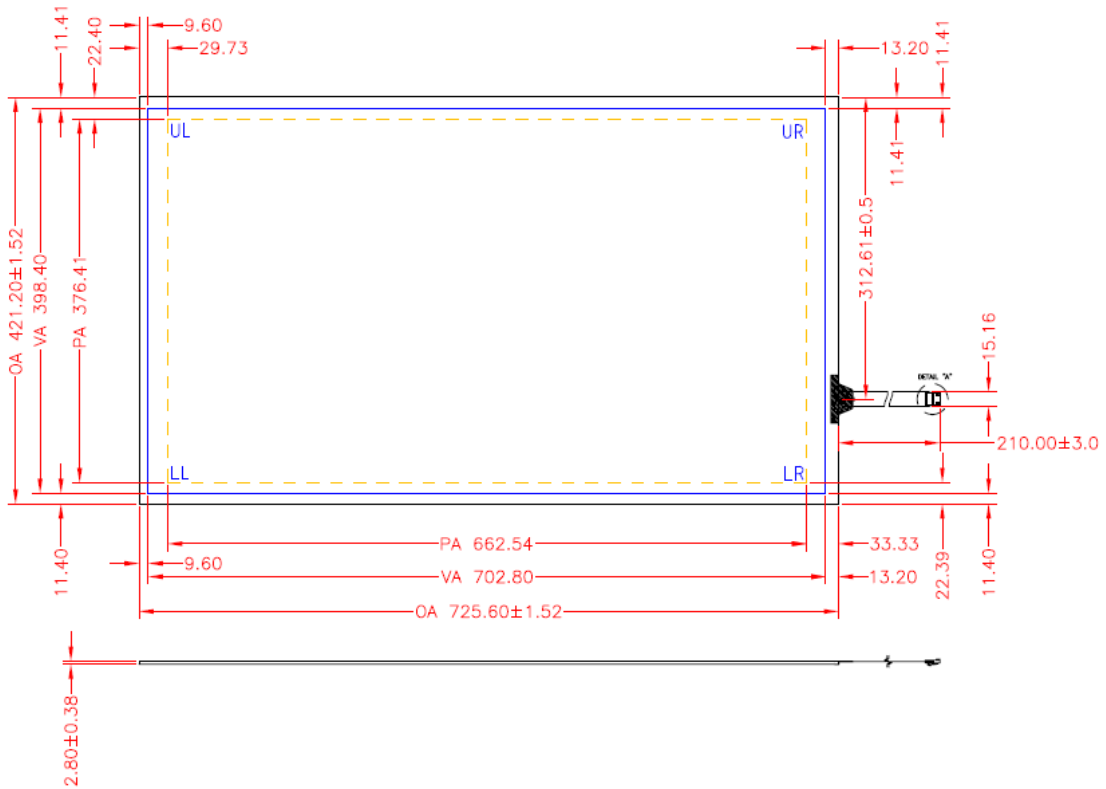

Controller Board (ESCAP7000)	
Circuit Board Dimension	62 mm x 33 mm
Power Requirements	D.C. +5V External power 5~12VDC unRegulated Power (max. 65mA, typical 55mA, 50mV peak to peak Max ripple)
Operating Temperature	-40 to 80 °C
Storage Temperature	-40 to 90 °C
Interface	USB: 2.0 compliant, Full Speed
Report rate	Max. 180 points/sec
Response Time	Max. 25ms

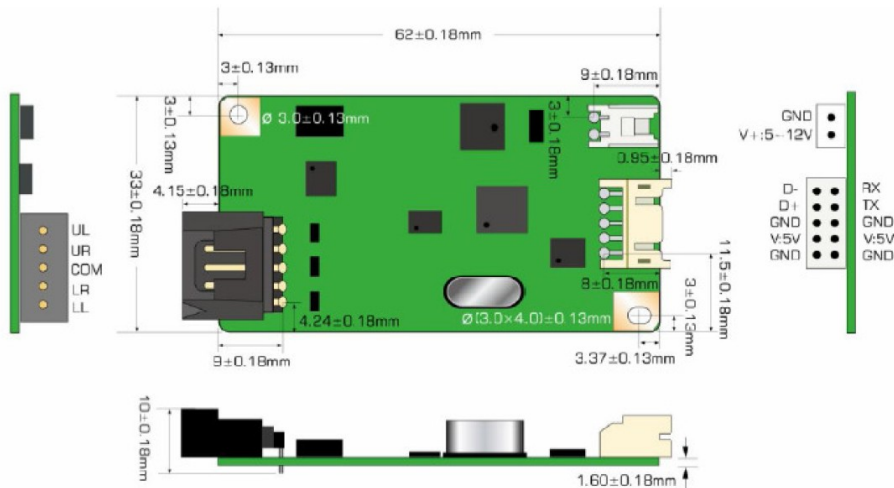

IV. OSD Function

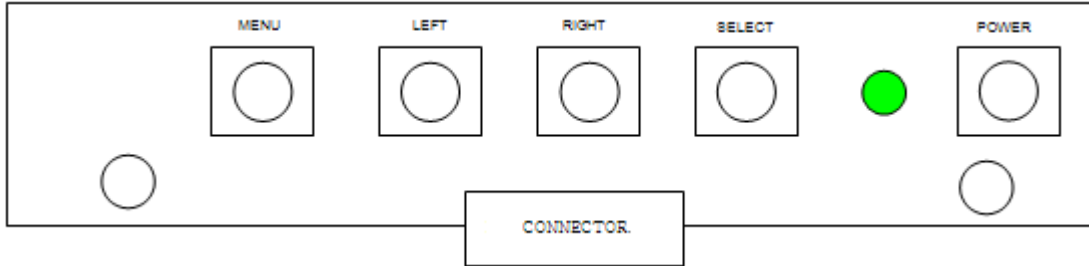

1) Button

Button	Function	Notes
POWER	Power on/off button - Turn power on or off	
MENU	Main menu on/off - Show OSD menu on the screen - Exit the main menu or sub menu	
RIGHT	Adjust button - Moves the bar right to increase the adjustment - Moves the main menu or sub menu	
LEFT	Adjust button - Moves the bar left to decrease the adjustment - Moves the main menu or sub menu	
SELECT	Menu select/Mode select - Moves the highlighted area to select one of the function - Analog or DVI select	

2) Menu

BRIGHTNESS /CONTRAST	Sub Menu : Brightness, Contrast) Use the 'Adjust -' or 'Adjust +' button to decrease or increase the setting
COLOR	Sub Menu : Color Temp. (Red, Green, Blue),Auto color Use the 'Adjust -' or 'Adjust +' button to decrease or increase the setting
POSITION	Sub Menu : Horizontal, Vertical, Clock, Phase, Auto Adjust Use the 'Adjust -' or 'Adjust +' button to decrease or increase the setting
SETUP	Sub Menu : OSD Position, OSD Time, OSD Language, Input Source, Scale Ratio, Recall, XGA/WXGA Sel. Use the 'Adjust -' or 'Adjust +' button to decrease or increase the setting
EXIT	Select one of the seven language

V. Environment Specifications

Parameter	Values		Units	Notes
	Min.	Max.		
Operating Temperature	0	+50	°C	
Storage Temperature	-20	+60	°C	
Operating Humidity	5	90	%RH	
Storage Humidity	5	90	%RH	

VI. Reliability

No.	Test Item		Conditions
1	High temperature operating test		Ta : 50°C, 120Hr
2	Low temperature operating test		Ta : 0°C, 120Hr
3	High temperature storage test		Ta : 60°C, 120Hr
4	Low temperature storage test		Ta : -20°C, 120Hr
5	High humidity operating test		Ta : 50°C, 80%RH, 120Hr
6	High humidity storage test		Ta : 50°C, 90%RH, 120Hr
7	Thermal shock operation test		Ta : 0°C, 60min → 0°C~50°C, 30min → 50°C, 60min, 50Cycle
8	Thermal shock storage test		Ta : -20°C, 60min → -20°C~60°C, 30min → 60°C, 60min, 50Cycle
9	ESD	Contact	8KV,1sec/cycle
		Air	15KV,1sec/cycle
10	Vibration (Non-Operation)		Wave form: random Vibration level : 1.0G RMS Bandwidth : 10-300Hz Duration : X,Y,Z 10min per axes X,Y,Z: Horizontal, face up
11	Shock (Non-Operation)		Shock level 50G ,20ms ±X,Y,Z axis Waveform: half sine wave Direction: One time each direction

VII. Inspection standard

1. Description

These inspection standards shall be applied to LCD monitor supplied by GTT.

2. The condition of inspection

2.1 Inspection Environment

- 1) Ambient temperature : 15~25°C
- 2) Humidity : 25~75%RH
- 3) Ambient Illumination :
 - 400~600Lux for external appearance inspection
 - 100~200Lux for light on inspection

2.2 Inspection condition

- Viewing Distance : 30~50^{cm} from the surface of the monitor.
- Viewing Angle : 90 degree to the front surface of display panel.
- Viewing Distance : 30^{cm} from the surface of the monitor.
- Viewing Angle : 90 degree to the front surface of display panel.
- Inspection time for 15seconds.
- while the monitor is on the display and while running the Color patterns(White/Red/Green/Blue)
- Under the inspection condition above, we judge a failure in the inspection if stain or finger print are detected by naked eyes .

2.3 Inspection resolution

1920×1080, 60Hz

3. Visual inspection

3.1 Packing inspection

Item	Standard	Inspection equipment
Carton label	The character(Model, P/N, S/N etc...) can be discerned.	* Visual
Box	No broken and dirty	

3.2 Appearance inspection of monitor

Item	Standard	Inspection equipment
Rear & side	No crack, Broken and Distortion	* Visual * Calipers * Steel scale
Scratch	Noticeable scratch and exfoliation coating are not permitted	
Mounting hole	No omission	
Rear label	The character(Model, P/N, S/N etc...) can be discerned.	
Dimension and hole size	Tolerance : ± 0.2mm	

3.3 LCD visual inspection

[unit : mm]

Item	Standard		Inspection equipment
Dot (Bright & Dark)	Random	$N \leq 10$	* PC for inspection * Pattern generator * Lupe : $\times 10$ * N-test program * ND Filter
	2 adjacent	$N \leq 5$ (Note 1)	
	3 adjacent or more	$N \leq 2$	
	Total	$N \leq 14$	
Mura(Note 4)	Judged by 2% ND filter in gray pattern		
Line defect	Not allowed		

* D : Diameter, W : Width, L : Length, N : Count

Note (1) Two dot adjacent

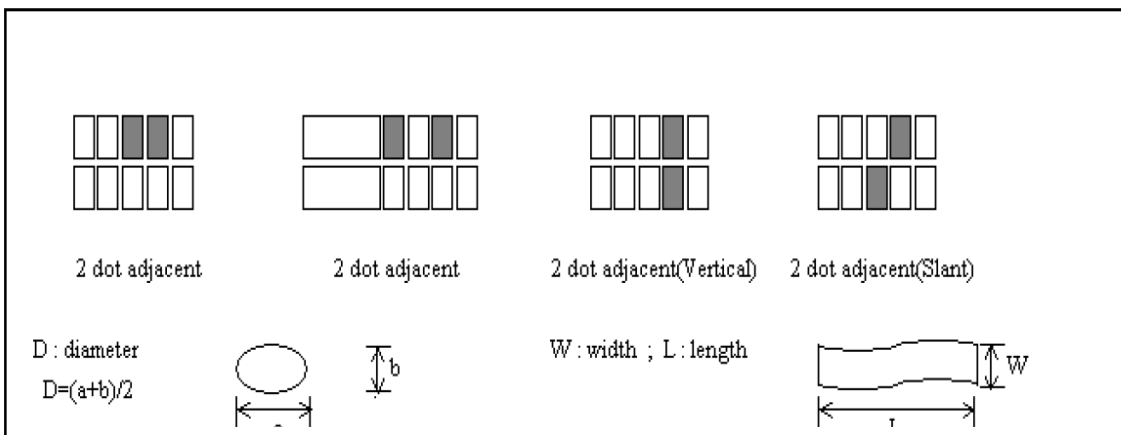

Note (4) The inspection method of ND filter – holding ND filter in front of the panel around 1cm

and examine the panel from 35 ± 5 cm in the front view for 3 seconds.

3.4 Touch glass & LCD Panel visual inspection

[unit ; mm]

Item	Defect size	Q'ty	Inspection equipment
Circular defect	$D < 2.0$	Ignore	* Visual * Lupe ; $\times 10$
	$D \geq 2.0$	0	
Liner defect (Scratch, Foreign object)	$W < 0.5, L < 20$	Ignore	
	$W \geq 0.5, L \geq 20$	0	

*out-of-box cosmetic criteria within the viewing area while the touch sensor is on the display and while running the “Colors” program

* Inspection method

- Position front of touch screen 50cm form your eye.
- Inspection for 15seconds.
- Use one of the following patterns to aid eye.

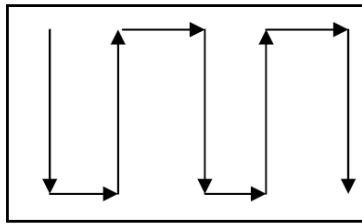

D : diameter
 $D=(a+b)/2$



W : width ; L : length

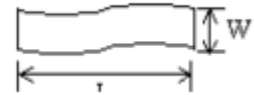

4. Function inspection (Resolution 1920*1080 at 60Hz)

4.1 OSD key function inspection

Item	Standard	Inspection equipment
Key function	Function normally each key button on the PC mode.	* PC

4.2 Display inspection

Item	Standard	Inspection equipment
Color	No strange color displaying	* PC * Pattern generator
Flicker	No flicker	
Noise	No critical noise	
Jittering	No critical jittering	
Power LED indicator	Power & signal on Green	

4.3 Function inspection of touch screen

Item	Standard	Inspection equipment
Accuracy	97%	* Finger

VIII. Accessory

1) VGA Cable

REMARK:

1. JUL 20276 [UL 1354(30AWG*1C+EA)*3+UL 1792(30AWG*1C+EA)*1+UL 1061 30AWG*5C+AB OD=15.5mm PVC JACKET COLOR:BLACK(HL-201)
2. HDB 15P(MALE,SOLID PIN,FULL PIN, PIN GF, BLACK INSULATION,SHELL TIN PLATED) AFTER INNER-MOLDED MUST ADD COPPER FOIL AND SOLDERED AROUND 360° TO CONNECTOR SHELL AND CABLE SHIELD THEN 45P PVC OUTER MOLDED (45P COLOR:BLUE 661C HL-501)
3. FERRITE CORE (OD)10.0(L)13.5*(ID)6.35mm
4. THUMB SCREW 2.8*L32mm #4-40 NI PLATED ABS MOLDED COLOR:BLUE 661C(HL-501)
5. PVC 45P COLOR:BLACK(HL-201)
6. DUST CAP:USED FOR HDB15P(M) PVC COLOR:CLEAR(HL-002).
7. FINISHED PRODUCT BENDING TEST:300g,±60°,250TIMES MIN,25CYCLES/MIN
8. SALT SPRAY:35±2°C SOLUTION 5±1% SPRAY 24 HOURS,PH=6.5-7.2 AIR PRESSURE 1.0±0.01KG/C² TEST RELATIVE HUMIDITY 10-85%,TEST STANDARD:CONTACT RESISTANCE LESS THAN TWICE OF INITIAL,NO EVIDENCE OF DAMAG

WIRE CONNECTION

P1 HDB15(M)	WIRE COLOR	P2 HDB15(M)
1	COAX RED WIRE	1
6	COAX RED GND	6
2	COAX GREEN WIRE	2
7	COAX GREEN GND	7
3	COAX BLUE WIRE	3
8	COAX BLUE GND	8
9	BLACK	9
10	VIOLET	10
12	ORANGE	12
13	COAX NATURE WIRE	13
14	YELLOW	14
15	WHITE	15
4		4
5		5
11	BRID-COAX NATURE GND	11
	SHELL	SHELL

TOLERANCES

	mm
X.	±
X. X	±
X. XX	±
X. XXX	±
X. XXXX	±

METRIC:MM

TOLERANCES		REVISIONS		CUSTOMER	SE MYOUNG
ECN NO.	REV	DESCRIPTION	DATE	HONGLIN PIN	110-2701
	A/0	INITIAL RELEASE	2006.02.08	CUSTOMER PIN	SM-071-10
				TOOLING	1052.2010
				CHECKED	0208/1630
				APPROVED	Tony-jss/1740

HONGLIN ELECTRONIC CO.,LTD
泓淋电子有限公司

TITLE: SIGNAL CABLE ASSY
 DRAWN: Betty
 DATE: 2006.02.08
 SHEET: 1/1
 REV: A/0
 DRAWING: 110-2701.DWG

2) DVI Cable

WIRE CONNECTION

DVI 18+1	COLOR	DVI 18+1
PIN 1	WHITE	PIN 1
PIN 2	RED	PIN 2
PIN 3	GND	PIN 3
PIN 6	VIOLET	PIN 6
PIN 7	RED	PIN 7
PIN 9	WHITE	PIN 9
PIN 10	GREEN	PIN 10
PIN 11	GND	PIN 11
PIN 14	YELLOW	PIN 14
PIN 15	ORANGE	PIN 15
PIN 16	WHITE	PIN 16
PIN 17	WHITE	PIN 17
PIN 18	BLUE	PIN 18
PIN 19	GND	PIN 19
PIN 22	GND	PIN 22
PIN 23	BROWN	PIN 23
PIN 24	WHITE	PIN 24
SHELL	BRAID	SHELL

REMARK:

1. UL20276 APPROVED (28AWG*1P+EAM)*4+28AWG*1P+28AWG*3C+DAB OD:Ø7.3mm
PVC JACKET COLOR:BLACK(HL-201)
2. DVI-D(18+1) MALE, ASSEMBLY TYPE, SOLID PIN, PIN G/F, BLACK INSULATION, SHELL NI PLATED
AFTER ADD METAL CAN AND SOLDERED AROUND 360° TO CONNECTOR SHELL AND CABLE SHIELD.
3. THUMB SCREW: Ø4.0*45mm #4-40 NI PLATED ABS MOLDED COLOR:BLACK(HL-201)
4. FERRITE CORE: (OD)17.5*(L)28.5*(ID)9.5mm
5. PVC: 45P COLOR:BLACK(HL-201)
6. SALT SPRAY: 35±2°C SOLUTION 5±1% SPRAY 24 HOURS
PH=6.5~7.2 AIR PRESSURE 1.0±0.01KGf/c
TEST RELATIVE HUMIDITY 10~85%
TEST STANDARD: CONTACT RESISTANCE LESS THAN
TWICE OF INITIAL, NO EVIDENCE OF DAMAGE

TOLERANCES	REVISIONS	CUSTOMER	SE MYOUNG
X. mm ±	REV	HONGLIN PIN	180-2300
X. X ±	A/0	CUSTOMER PIN	DVI-D TO DVI-D CABLE(1.8M)
X. XX ±		TOOLING	1002.2037
X. XXX ±		CHECKED	<i>Tony</i>
X. XXXX ±		APPROVED	<i>Tony</i>
METRIC:MM			

HONGLIN ELECTRONIC CO.,LTD
弘霖电子有限公司

REVISIONS

DATE: 2006.02.07
DRAWN: Betty
SCALE: NONE
SHEET: 1/1 REV: A/0
DRAWING: 180-2300.DWG

3) AC Cord

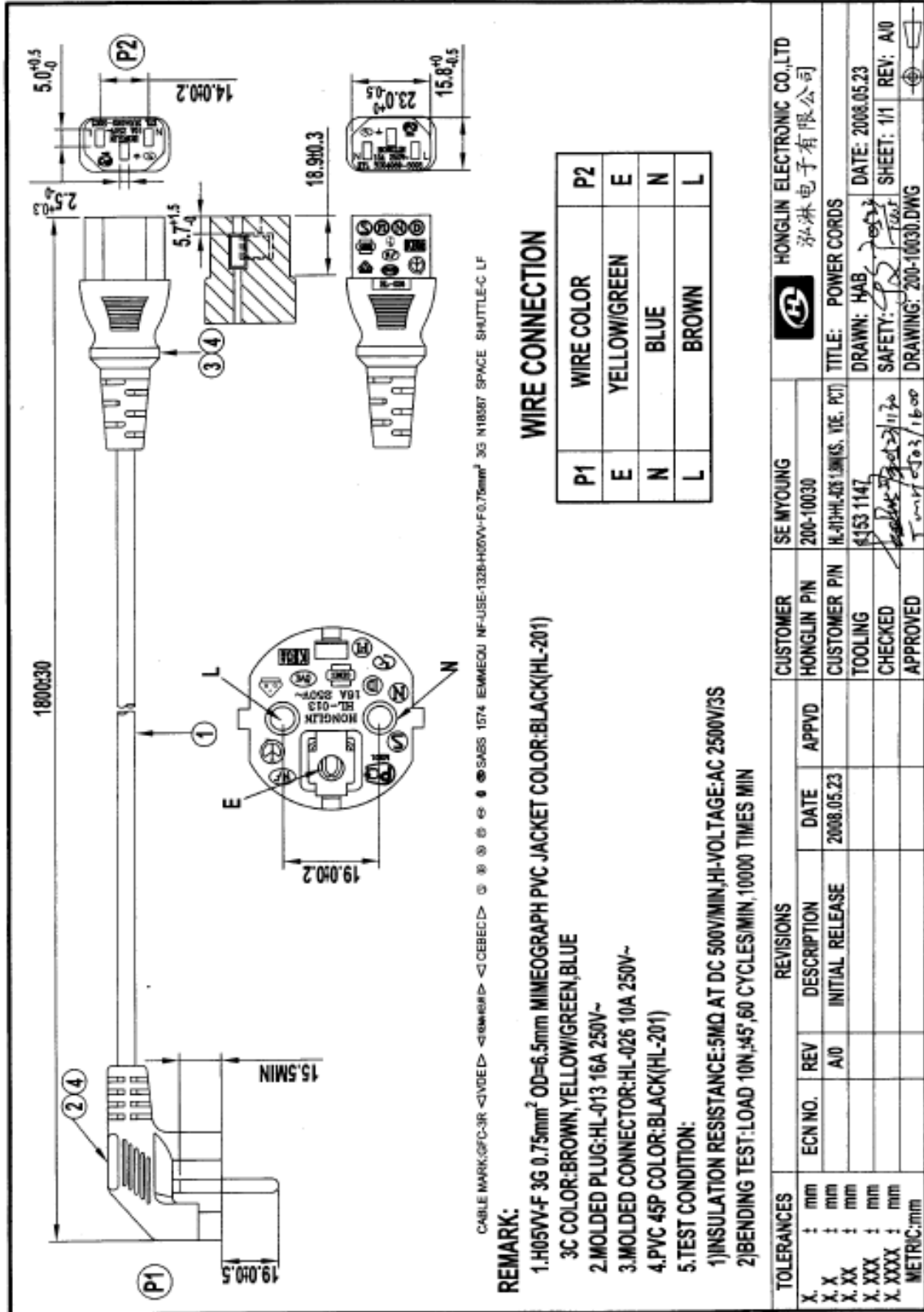

4) USB Cable

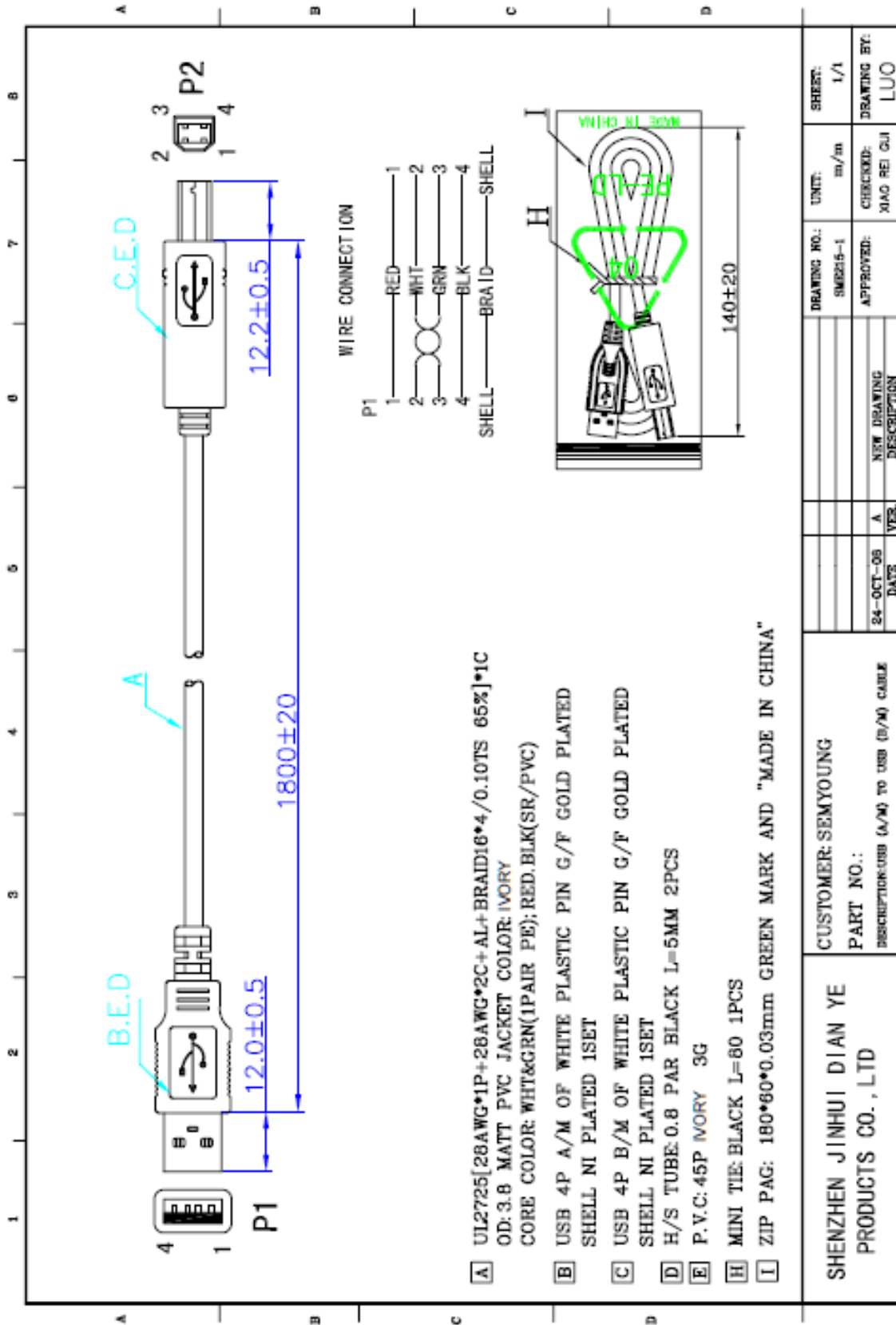

5) Adaptor

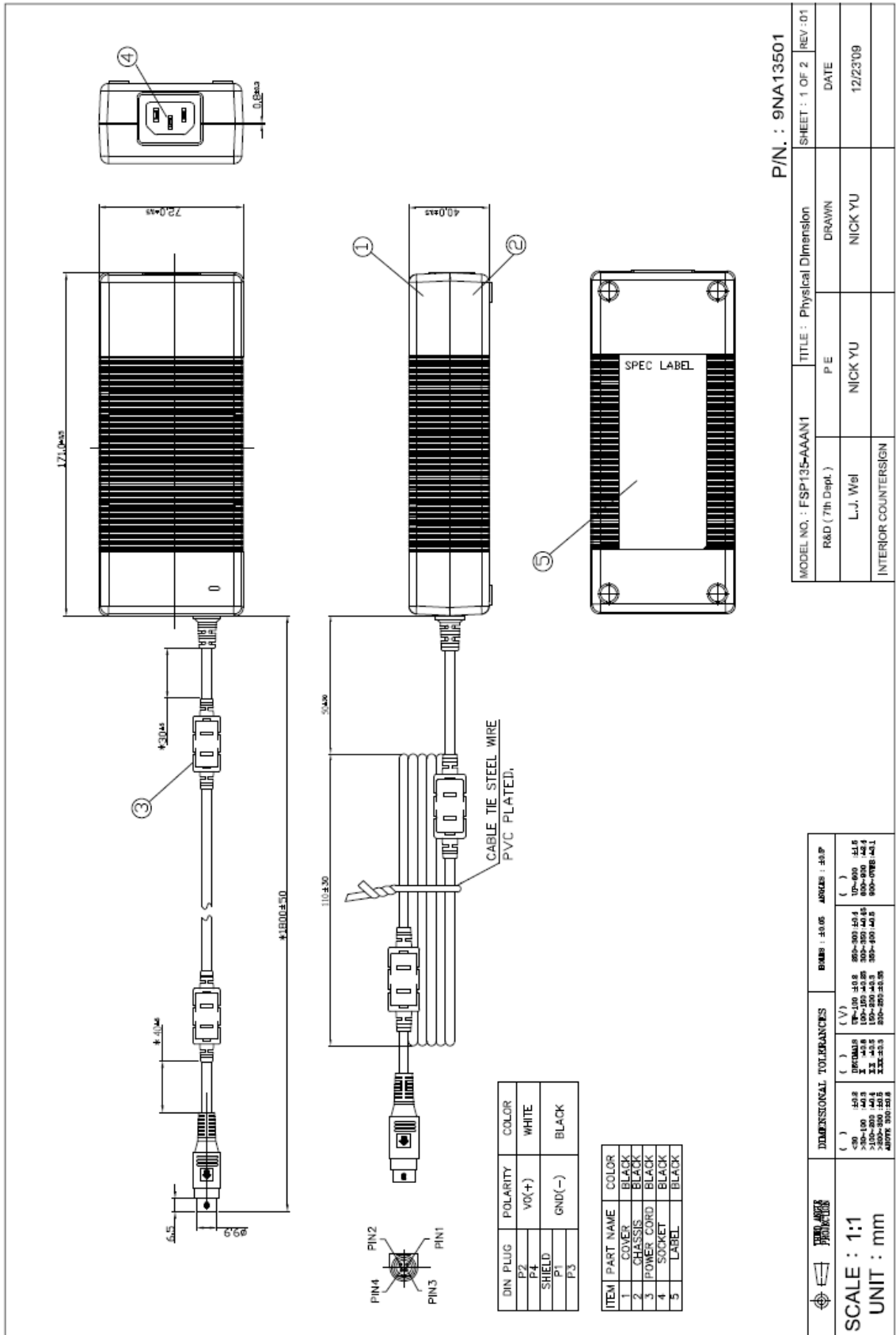

IX. Mechanical Characteristics

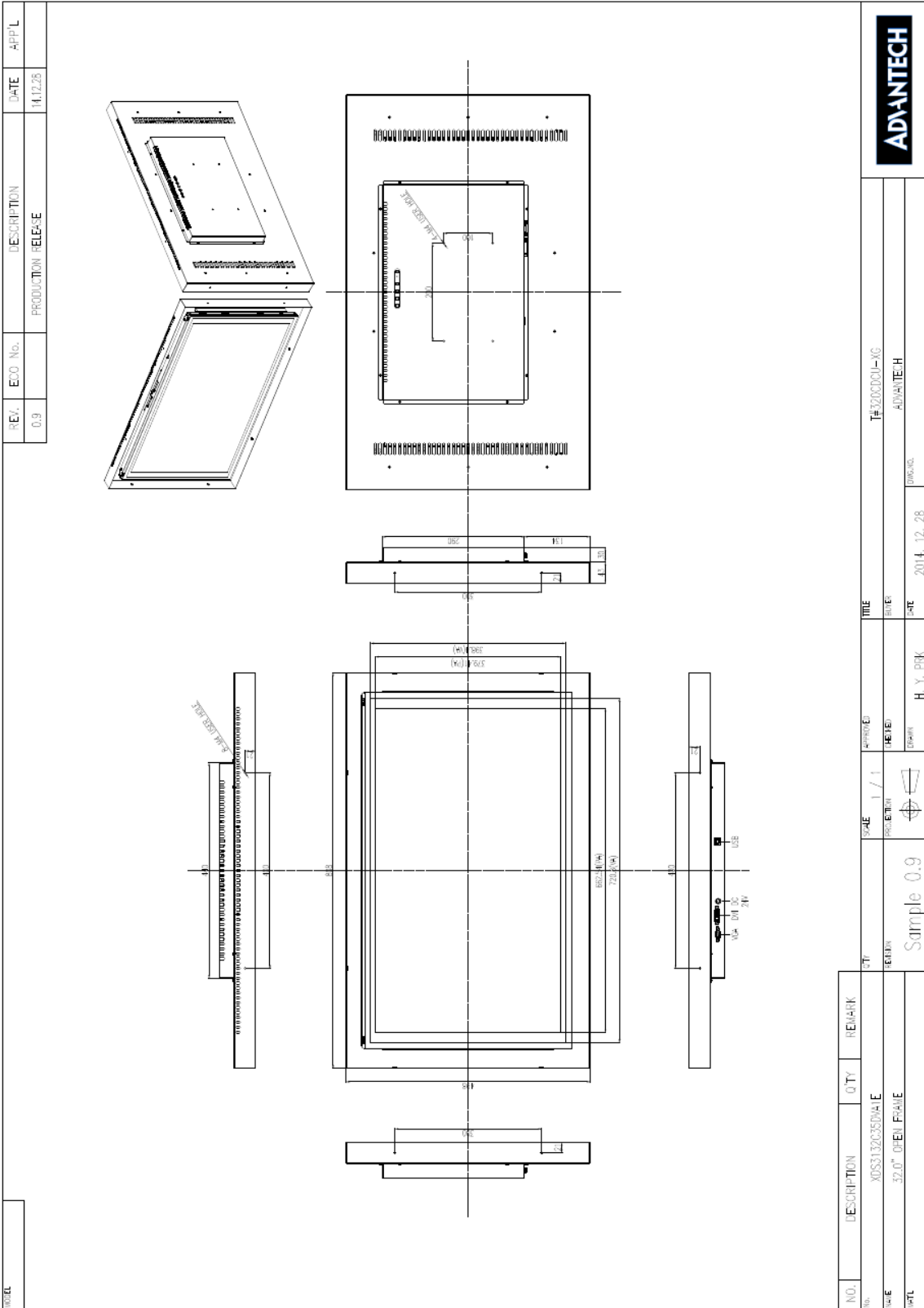

X. Packing

1) Packing Method

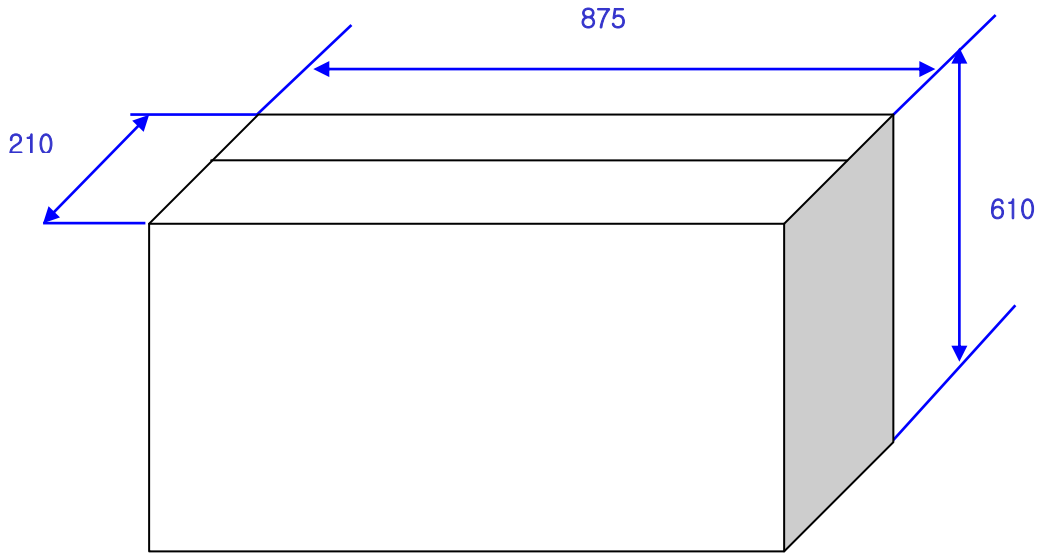

Gift Box (1 monitor)

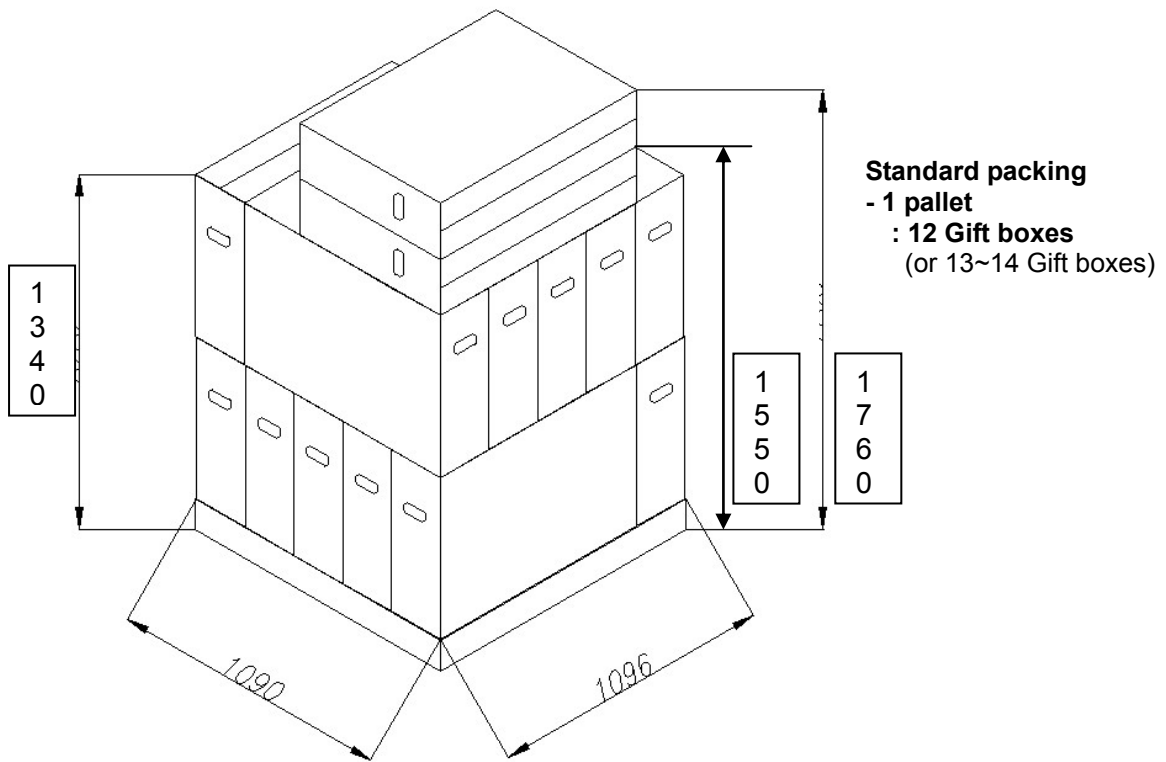

Pallet (Gift box X 12 or ~14)