

SERPAC 152Ri4AA (exploded isometric)

Electronic Enclosures

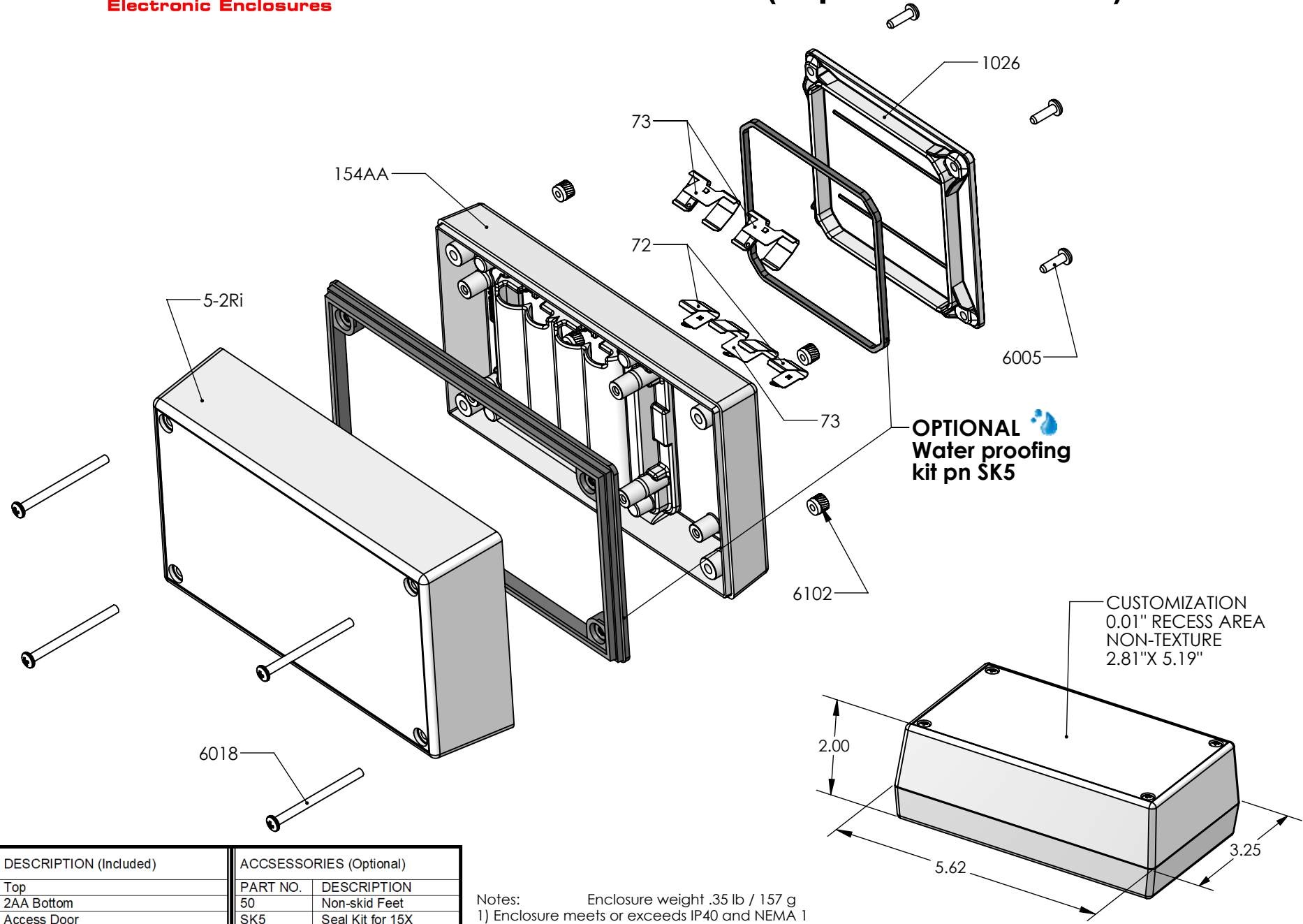

PART NO.	DESCRIPTION (Included)	ACCESSORIES (Optional)
5-2Ri	Top	PART NO. DESCRIPTION
152AA	2AA Bottom	50 Non-skid Feet
1026	Access Door	SK5 Seal Kit for 15X
6005	#4X3/8" Self-Tapping Screw (4)	
6018	4-40 Screw (4)	
6102	4-40 Threaded Insert (4)	
73	Double Battery Contact (3)	
72	Single Battery Contact (2)	

Notes: Enclosure weight .35 lb / 157 g
 1) Enclosure meets or exceeds IP40 and NEMA 1
 2) When used with SK5 the enclosure meets or exceeds IP 67 and NEMA 4X, 12 and 13 MIL-STD-810G 506.5 (.02 lb / 11g)
 3) Circuit Board drawings see sheet 3.
 4) All components are RoHS Compliant.

ALL DIMENSIONS ARE ± .010" 11/16/2021 (1 of 3)
 2009 Wright Ave. La Verne, CA 91750
 Ph. (626) 331-0517 Fx. (626) 331-8584 serpac.com

SERPAC 152Ri4AA

Electronic Enclosures

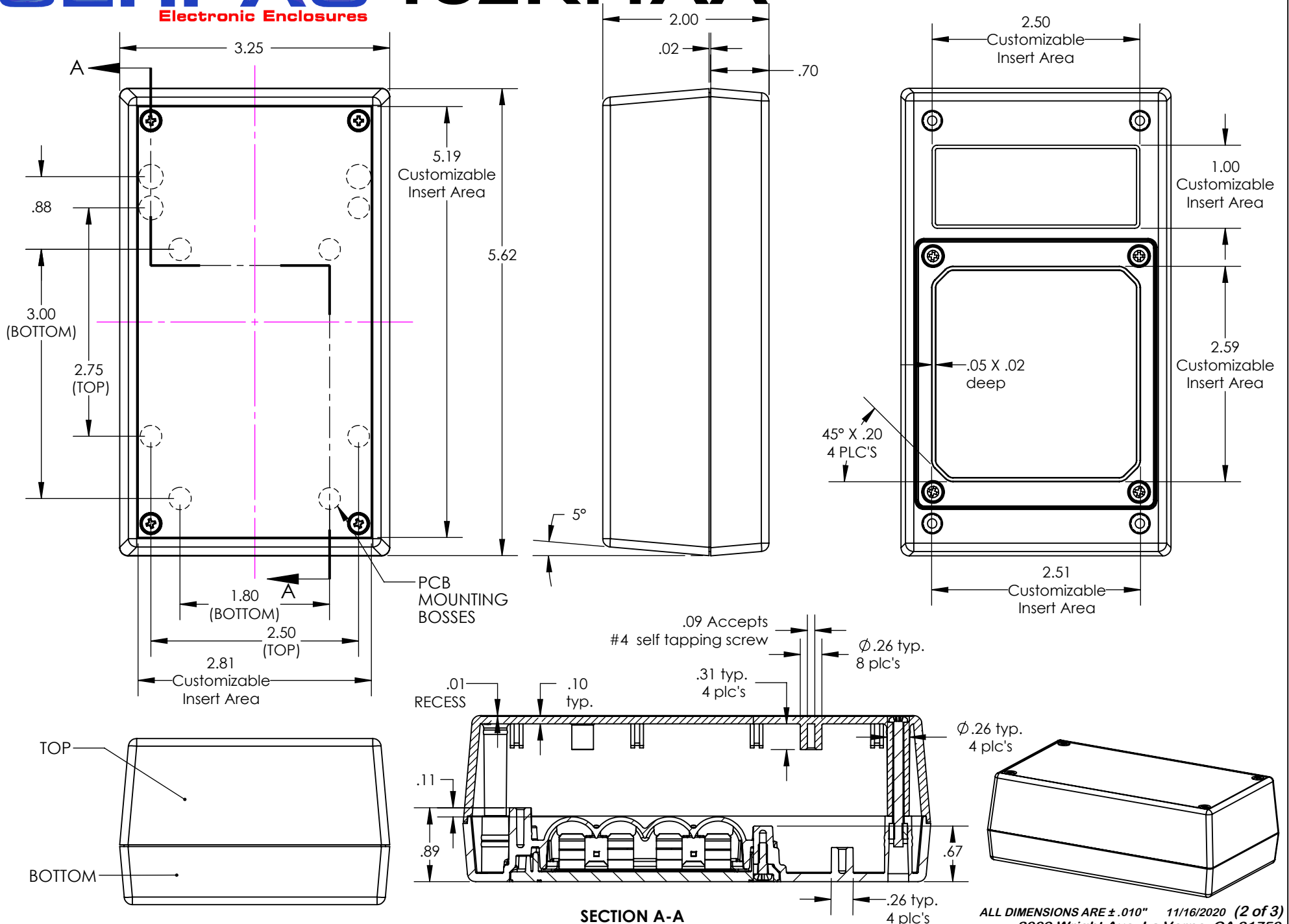

SECTION A-A

ALL DIMENSIONS ARE ±.010" 11/16/2020 (2 of 3)
2009 Wright Ave. La Verne, CA 91750
Ph. (626) 331-0517 Fx. (626) 331-8584 www.serpac.com

SERPAC PCB for 15X compartment enclosures

Electronic Enclosures

CIRCUIT BOARD FOR TOP

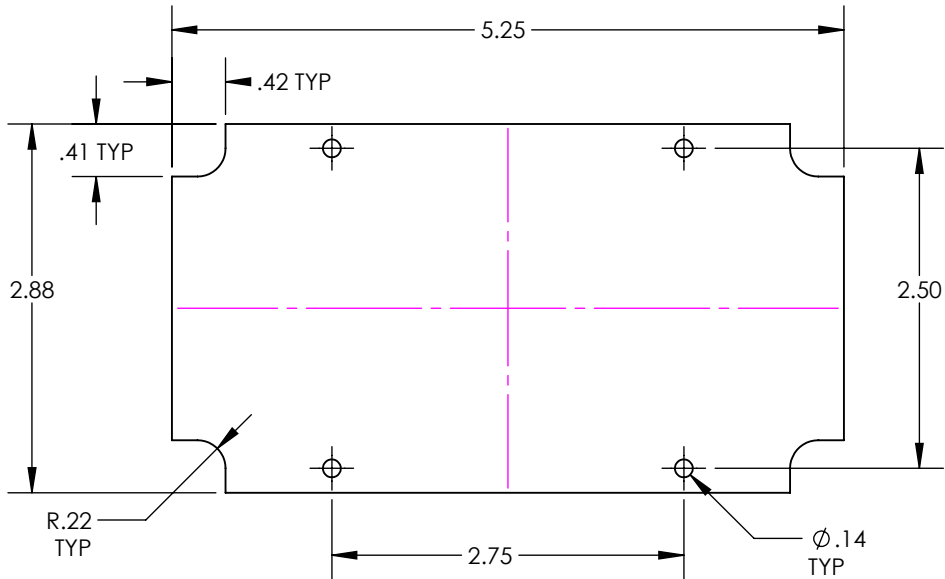

CIRCUIT BOARD FOR BOTTOM

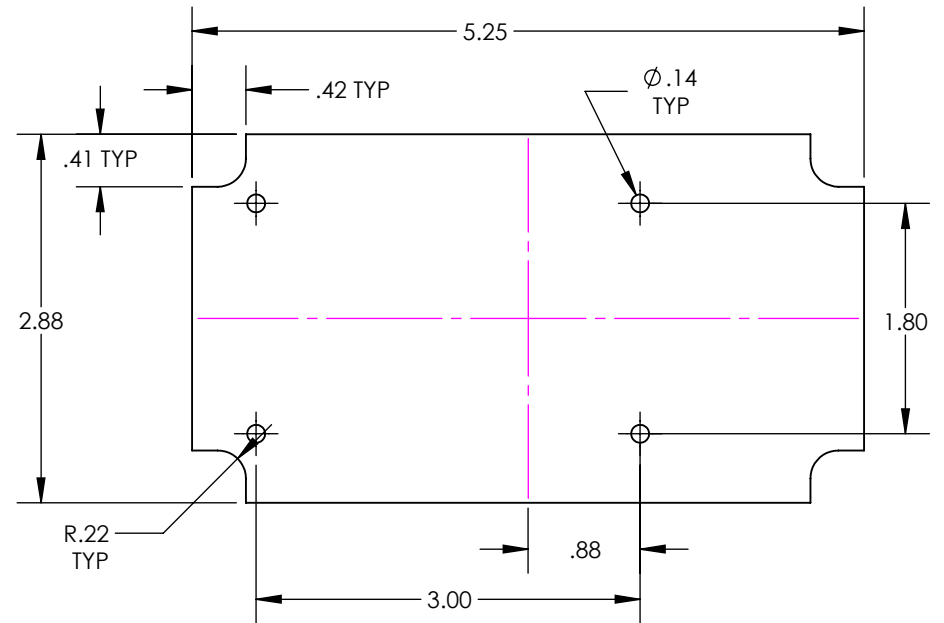

SMALL CIRCUIT BOARD FOR BOTTOM

