

FEATURES

- Controls supply voltages from 2 V to 20 V
- 370 ns response time to short circuit
- Resistor-programmable 5 mV to 25 mV current limit
- ±1% accurate, 12-bit ADC for current, V_{IN}/V_{OUT} readback
- Charge-pumped gate drive for multiple external N-channel FETs
- High gate drive voltage to ensure lowest $R_{DS(ON)}$
- Foldback for tighter FET SOA protection
- Automatic retry or latch-off on current fault
- Programmable current limit timer for SOA
- Programmable, multifunction GPOs
- Power-good status output
- Analog UV and OV protection
- ENABLE pin (ADM1275-3 only)
- Peak detect registers for current and voltage
- PMBus fast mode compliant interface
- 16-lead QSOP and 20-lead QSOP and LFCSP

APPLICATIONS

- Power monitoring and control/power budgeting
- Central office equipment
- Telecommunication and data communication equipment
- PCs/servers

GENERAL DESCRIPTION

The [ADM1275](#) is a hot-swap controller that allows a circuit board to be removed from or inserted into a live backplane. It also features current and voltage readback via an integrated 12-bit analog-to-digital converter (ADC), accessed using a PMBus™ interface. The load current is measured using an internal current sense amplifier that measures the voltage across a sense resistor in the power path via the SENSE+ and SENSE– pins. A default limit of 20 mV is set, but this limit can be adjusted, if required, using a resistor divider network from the internal reference voltage to the ISET pin.

The [ADM1275](#) limits the current through the sense resistor by controlling the gate voltage of an external N-channel FET in the power path, via the GATE pin. The sense voltage—and, therefore, the load current—is maintained below the preset maximum. The [ADM1275](#) protects the external FET by limiting the time that the FET remains on while the current is at its maximum value. This current limit time is set by the choice of capacitor connected to the TIMER pin. In addition, a foldback resistor network can be used to actively lower the current limit as the voltage across the FET is increased. This helps to maintain constant power in the FET and allows the safe operating area (SOA) to be adhered to in an effective manner.

APPLICATIONS DIAGRAM

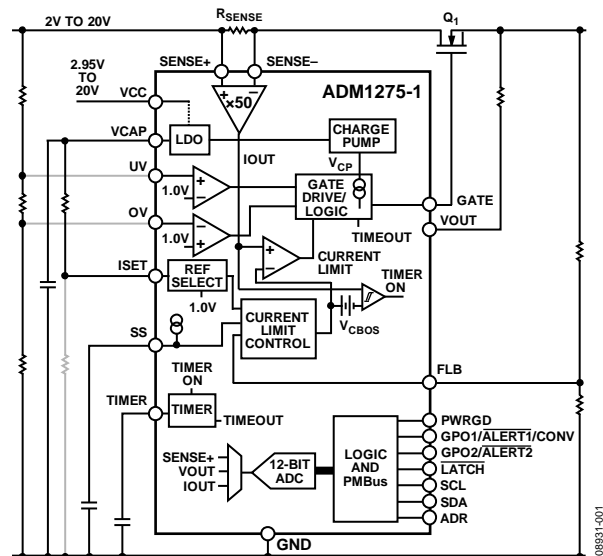

Figure 1.

In case of a short-circuit event, a fast internal overcurrent detector responds within 370 ns and signals the gate to shut down. A 1500 mA pull-down device ensures a fast FET response. The [ADM1275](#) features overvoltage and undervoltage protection, programmed using external resistor dividers on the UV and OV pins. A PWRGD signal can be used to detect when the output supply is valid, using the FLB pin to monitor the output. GPO pins can be configured as various output signals that can be asserted when a programmed current or voltage level is reached.

The 12-bit ADC can measure the current in the sense resistor, as well as the supply voltage on the SENSE+ pin or the output voltage. A PMBus interface allows a controller to read current and voltage data from the ADC. Measurements can be initiated by a PMBus command. Alternatively, the ADC can run continuously, and the user can read the latest conversion data whenever required. Up to four unique PMBus addresses can be selected, depending on the way that the ADR pin is connected.

The [ADM1275-1](#) and [ADM1275-3](#) are available in a 20-lead QSOP and 20-lead LFCSP and have a LATCH pin that can be configured for automatic retry or latch-off when an overcurrent fault occurs. The [ADM1275-2](#) is available in a 16-lead QSOP with latch-off mode only.

Rev. E

Document Feedback

Information furnished by Analog Devices is believed to be accurate and reliable. However, no responsibility is assumed by Analog Devices for its use, nor for any infringements of patents or other rights of third parties that may result from its use. Specifications subject to change without notice. No license is granted by implication or otherwise under any patent or patent rights of Analog Devices. Trademarks and registered trademarks are the property of their respective owners.

TABLE OF CONTENTS

| | | | |
|--|----|---|----|
| Features | 1 | Status Commands | 30 |
| Applications..... | 1 | GPO and Alert Pin Setup Commands | 31 |
| Applications Diagram | 1 | Power Monitor Commands | 31 |
| General Description | 1 | Warning Limit Setup Commands | 32 |
| Revision History | 3 | PMBus Direct Format Conversion | 32 |
| Specifications..... | 4 | Voltage and Current Conversion using LSB values | 33 |
| Serial Bus Timing Characteristics | 7 | ADM1275 Alert Pin Behavior | 34 |
| Absolute Maximum Ratings..... | 8 | Faults and Warnings | 34 |
| Thermal Characteristics | 8 | Generating an Alert | 34 |
| ESD Caution..... | 8 | Handling/Clearing an Alert | 34 |
| Pin Configurations and Function Descriptions | 9 | SMBus Alert Response Address | 35 |
| Typical Performance Characteristics | 14 | Example Use of SMBus Alert Response Address | 35 |
| Functional Block Diagrams..... | 20 | PMBus Command Reference..... | 36 |
| Theory of Operation | 21 | OPERATION | 37 |
| Powering the ADM1275 | 21 | CLEAR_FAULTS..... | 37 |
| Current Sense Inputs..... | 21 | CAPABILITY | 37 |
| Current Limit Reference..... | 22 | VOUT_OV_WARN_LIMIT | 37 |
| Setting the Current Limit (ISET) | 22 | VOUT_UV_WARN_LIMIT..... | 37 |
| Soft Start | 23 | IOUT_OC_WARN_LIMIT | 37 |
| Foldback..... | 23 | IOUT_WARN2_LIMIT..... | 38 |
| Timer | 24 | VIN_OV_WARN_LIMIT | 38 |
| Hot-Swap Retry Duty Cycle..... | 24 | VIN_UV_WARN_LIMIT | 38 |
| FET Gate Drive Clamps..... | 24 | STATUS_BYTE | 38 |
| Fast Response to Severe Overcurrent | 25 | STATUS_WORD..... | 39 |
| Undervoltage and Overvoltage..... | 25 | STATUS_VOUT | 39 |
| ENABLE Input (ADM1275-3 Only) | 25 | STATUS_IOUT | 39 |
| Power Good..... | 25 | STATUS_INPUT..... | 40 |
| VOUT Measurement | 26 | STATUS_MFR_SPECIFIC..... | 40 |
| FET Health | 26 | READ_VIN | 40 |
| Power Monitor | 26 | READ_VOUT..... | 41 |
| PMBus Interface | 27 | READ_IOUT | 41 |
| Device Addressing..... | 27 | PMBUS_REVISION | 41 |
| SMBus Protocol Usage..... | 27 | MFR_ID..... | 41 |
| Packet Error Checking..... | 27 | MFR_MODEL | 41 |
| Partial Transactions on I ² C Bus | 27 | MFR_REVISION..... | 42 |
| SMBus Message Formats | 28 | PEAK_IOUT..... | 42 |
| Group Commands..... | 29 | PEAK_VIN..... | 42 |
| Hot-Swap Control Commands..... | 30 | PEAK_VOUT | 42 |
| ADM1275 Information Commands | 30 | PMON_CONTROL..... | 42 |

PMON_CONFIG43
 ALERT1_CONFIG43
 ALERT2_CONFIG44
 DEVICE_CONFIG45

POWER_CYCLE45
 Outline Dimensions.....46
 Ordering Guide47

REVISION HISTORY

5/2019—Rev. D to Rev. E

Added Endnote 1, Table 27

11/2013—Rev. C to Rev. D

Changes to GATE Pin Parameter, Table 1.....4

4/2013—Rev. B to Rev. C

Added Partial Transactions on I²C Bus Section27

6/2011—Rev. A to Rev. B

Changes to t_{BUF} Parameter7
 Added Conditions Statement to Table 27
 Changes to VOUT Pin Description, Table 510
 Changes to VOUT Pin Description, Table 613
 Changes to Figure 4219
 Changes to Current Sense Inputs Section.....21

Added PMBus Direct Format Conversion Section32
 Added Voltage and Current Conversion Using LSB Values Section.....33
 Changes to Handling/Clearing and Alert Section.....34

10/2010—Rev. 0 to Rev. A

Added 20-Lead LFCSP Universal
 Changes to Table 4 8
 Added Figure 4; Renumbered Figures Sequentially 9
 Changes to Table 5 9
 Added Table 6; Renumbered Tables Sequentially 11
 Added Figure 7 and Table 7 12
 Updated Outline Dimensions.....48
 Changes to Ordering Guide.....48

9/2010—Revision 0: Initial Version

SPECIFICATIONS

$V_{CC} = 2.95\text{ V to }20\text{ V}$, $V_{CC} \geq V_{SENSE+}$, $V_{SENSE+} = 2\text{ V to }20\text{ V}$, $V_{SENSE} = (V_{SENSE+} - V_{SENSE-}) = 0\text{ V}$, $T_A = -40^\circ\text{C to }+85^\circ\text{C}$, unless otherwise noted.

Table 1.

| Parameter | Min | Typ | Max | Unit | Test Conditions/Comments |
|---|------|------|------|---------------|--|
| POWER SUPPLY | | | | | |
| Operating Voltage Range, V_{CC} | 2.95 | | 20 | V | V _{CC} rising |
| Undervoltage Lockout | 2.4 | | 2.7 | V | |
| Undervoltage Hysteresis | | 90 | 120 | mV | |
| Quiescent Current, I_{CC} | | | 5 | mA | GATE on and power monitor running |
| UV PIN | | | | | |
| Input Current, I_{UV} | | | 100 | nA | $UV \leq 3.6\text{ V}$ |
| UV Threshold, UV_{TH} | 0.97 | 1.0 | 1.03 | V | UV falling |
| UV Threshold Hysteresis, UV_{HYST} | 40 | 50 | 60 | mV | |
| UV Glitch Filter, UV_{GF} | 2 | | 7 | μs | 50 mV overdrive |
| UV Propagation Delay, UV_{PD} | | 5 | 8 | μs | UV low to GATE pull-down active |
| OV PIN | | | | | |
| Input Current, I_{OV} | | | 100 | nA | ADM1275-1 and ADM1275-3 $OV \leq 3.6\text{ V}$ |
| OV Threshold, OV_{TH} | 0.97 | 1.0 | 1.03 | V | OV rising |
| OV Threshold Hysteresis, OV_{HYST} | 50 | 60 | 70 | mV | |
| OV Glitch Filter, OV_{GF} | 0.5 | | 1.5 | μs | 50 mV overdrive |
| OV Propagation Delay, OV_{PD} | | 1.0 | 2 | μs | OV high to GATE pull-down active |
| SENSE+ AND SENSE- PINS | | | | | |
| Input Current, I_{SENSE} | | | 150 | μA | Per individual pin; SENSE+, SENSE- = 20 V $I_{\Delta SENSE} = (I_{SENSE+}) - (I_{SENSE-})$ |
| Input Imbalance, $I_{\Delta SENSE}$ | | | 5 | μA | |
| VCAP PIN | | | | | |
| Internally Regulated Voltage, V_{VCAP} | 2.66 | 2.7 | 2.74 | V | $0\text{ }\mu\text{A} \leq I_{VCAP} \leq 100\text{ }\mu\text{A}$; $C_{VCAP} = 1\text{ }\mu\text{F}$ |
| ISET PIN | | | | | |
| Reference Select Threshold, $V_{ISETRSTH}$ | 1.35 | 1.5 | 1.65 | V | If $V_{ISET} > V_{ISETRSTH}$, an internal 1 V reference (V_{CLREF}) is used Accuracies included in total sense voltage accuracies Accuracies included in total sense voltage accuracies $V_{ISET} \leq V_{VCAP}$ |
| Internal Reference, V_{CLREF} | | 1 | | V | |
| Gain of Current Sense Amplifier, AV_{CSAMP} | | 50 | | V/V | |
| Input Current, I_{ISET} | | | 100 | nA | |
| GATE PIN | | | | | |
| Maximum voltage on the gate is always clamped to $\leq 31\text{ V}$ | | | | | |
| Gate Drive Voltage, ΔV_{GATE} | 10 | 12 | 14 | V | $\Delta V_{GATE} = V_{GATE} - V_{SENSE+}$ $15\text{ V} \geq V_{CC} \geq 8\text{ V}$; $I_{GATE} \leq 5\text{ }\mu\text{A}$ |
| | 4.5 | | 13 | V | $20\text{ V} \geq V_{CC} \geq 15\text{ V}$; $I_{GATE} \leq 5\text{ }\mu\text{A}$ |
| | 8 | | 10 | V | $V_{SENSE+} = V_{CC} = 5\text{ V}$; $I_{GATE} \leq 5\text{ }\mu\text{A}$ |
| | 4.5 | | 6 | V | $V_{SENSE+} = V_{CC} = 2.95\text{ V}$; $I_{GATE} \leq 1\text{ }\mu\text{A}$ |
| Gate Pull-Up Current, I_{GATEUP} | -20 | | -30 | μA | $V_{GATE} = 0\text{ V}$ |
| Gate Pull-Down Current, I_{GATEDN_REG} | 45 | 60 | 75 | μA | $V_{GATE} \geq 2\text{ V}$; $V_{ISET} = 1.0\text{ V}$; $(SENSE+) - (SENSE-) = 30\text{ mV}$ |
| Gate Pull-Down Current, I_{GATEDN_SLOW} | 5 | 10 | 15 | mA | $V_{GATE} \geq 2\text{ V}$ |
| Gate Pull-Down Current, I_{GATEDN_FAST} | 750 | 1500 | 2000 | mA | $V_{GATE} \geq 12\text{ V}$; $V_{CC} \geq 12\text{ V}$ |
| Gate Holdoff Resistance | | 20 | | Ω | $V_{CC} = 0\text{ V}$ |
| HOT-SWAP SENSE VOLTAGE | | | | | |
| Hot-Swap Sense Voltage Current Limit, $V_{SENSECL}$ | 19.6 | 20 | 20.4 | mV | $V_{ISET} > 1.65\text{ V}$; $V_{FLB} > 1.12\text{ V}$; $V_{GATE} = (SENSE+) + 3\text{ V}$; $I_{GATE} = 0\text{ }\mu\text{A}$; $V_{SS} \geq 2\text{ V}$ |
| Foldback Inactive | 24.6 | 25 | 25.4 | mV | $V_{GATE} = (SENSE+) + 3\text{ V}$; $I_{GATE} = 0\text{ }\mu\text{A}$; $V_{SS} \geq 2\text{ V}$ $V_{ISET} = 1.25\text{ V}$; $V_{FLB} > 1.395\text{ V}$ |
| | 19.6 | 20 | 20.4 | mV | $V_{ISET} = 1.0\text{ V}$; $V_{FLB} > 1.12\text{ V}$ |
| | 9.6 | 10 | 10.4 | mV | $V_{ISET} = 0.5\text{ V}$; $V_{FLB} > 0.57\text{ V}$ |
| | 4.6 | 5 | 5.4 | mV | $V_{ISET} = 0.25\text{ V}$; $V_{FLB} > 0.295\text{ V}$ |
| Foldback Active | 3.5 | 4 | 4.5 | mV | $V_{FLB} = 0\text{ V}$; $V_{GATE} = (SENSE+) + 3\text{ V}$; $I_{GATE} = 0\text{ }\mu\text{A}$; $V_{SS} \geq 1\text{ V}$ |
| | 9.6 | 10 | 10.4 | mV | $V_{ISET} > 1.0\text{ V}$; $V_{FLB} = 0.5\text{ V}$; $V_{GATE} = (SENSE+) + 3\text{ V}$; $I_{GATE} = 0\text{ }\mu\text{A}$; $V_{SS} \geq 1\text{ V}$ |

| Parameter | Min | Typ | Max | Unit | Test Conditions/Comments |
|---|------|------|------|---------------|---|
| Circuit Breaker Offset, V_{CBOS} | 0.6 | 0.88 | 1.12 | mV | Circuit breaker trip voltage, $V_{CB} = V_{SENSECL} - V_{CBOS}$ |
| SEVERE OVERCURRENT | | | | | |
| Voltage Threshold, $V_{SENSEOC}$ | 40 | | 50 | mV | $V_{ISET} = 1.0\text{ V}$; $V_{FLB} > 1.1\text{ V}$; $V_{SS} \geq 2\text{ V}$ |
| Short Glitch Filter Duration | 9.5 | | 13.0 | mV | $V_{ISET} = 0.25\text{ V}$; $V_{FLB} > 1.1\text{ V}$; $V_{SS} \geq 2\text{ V}$ |
| Long Glitch Filter Duration (Default) | 90 | | 200 | ns | $V_{ISET} > 1.65\text{ V}$; V_{SENSE} driven from 18 mV to 52 mV; selectable via PMBus |
| Response Time | 530 | | 900 | ns | V_{SENSE} driven from 18 mV to 52 mV |
| With Short Glitch Filter | 180 | | 370 | ns | 2 mV overdrive maximum severe overcurrent threshold |
| With Long Glitch Filter | 645 | | 1020 | ns | |
| SOFT START (SS PIN) | | | | | |
| SS Pull-Up Current, I_{SS} | -12 | -10 | -8 | μA | $V_{SS} = 0\text{ V}$ |
| Default $V_{SENSECL}$ Limit | 0.5 | 1.25 | 1.8 | mV | When V_{SENSE} reaches this level, I_{SS} is enabled, ramping $V_{SENSECL}$; $V_{SS} = 0\text{ V}$ |
| SS Pull-Down Current | | 100 | | μA | $V_{SS} = 1\text{ V}$ |
| TIMER PIN | | | | | |
| Timer Pull-Up Current (POR), $I_{TIMERUPPOR}$ | -2 | -3 | -4 | μA | Initial power-on reset; $V_{TIMER} = 0.5\text{ V}$ |
| Timer Pull-Up Current (OC Fault), $I_{TIMERUPFLT}$ | -57 | -60 | -63 | μA | Overcurrent fault; $0.2\text{ V} \leq V_{TIMER} \leq 1\text{ V}$ |
| Timer Pull-Down Current (Retry), $I_{TIMERDNRT}$ | 1.7 | 2 | 2.3 | μA | After fault when GATE is off; $V_{TIMER} = 0.5\text{ V}$ |
| Timer Retry/OC Fault Current Ratio | | 3.33 | 3.8 | % | Defines the limits of the autoretry duty cycle |
| Timer Pull-Down Current (Hold), $I_{TIMERDNHOLD}$ | | 100 | | μA | Holds TIMER at 0 V when inactive; $V_{TIMER} = 0.5\text{ V}$ |
| Timer High Threshold, V_{TIMERH} | 0.98 | 1.0 | 1.02 | V | |
| Timer Low Threshold, V_{TIMERL} | 0.18 | 0.2 | 0.22 | V | |
| FOLDBACK (FLB PIN) | | | | | |
| FLB and PWRGD Threshold, V_{FLBTH} | 1.08 | 1.1 | 1.12 | V | FLB rising; $V_{ISET} = 1.0\text{ V}$ |
| Input Current, I_{FLB} | | | 100 | nA | $V_{FLB} \leq 1.0\text{ V}$; $V_{ISET} = 1.25\text{ V}$ |
| | | | 100 | nA | $V_{VCAP} \leq V_{FLB} \leq 20\text{ V}$ |
| Hysteresis Current | 1.7 | | 2.3 | μA | |
| Internal Hysteresis Voltage | 1.9 | | 3.1 | mV | Voltage drop across the internal 1.3 k Ω resistor |
| Power-Good Glitch Filter, $PWRGD_{GF}$ | 0.3 | 0.7 | 1 | μs | 50 mV overdrive |
| Minimum Foldback Clamp | | 200 | | mV | Accuracies included in total sense voltage accuracies |
| VOUT PIN | | | | | |
| Input Current | | | 20 | μA | ADM1275-1 and ADM1275-3 $V_{OUT} = 20\text{ V}$ |
| LATCH PIN | | | | | |
| Output Low Voltage, V_{OL_LATCH} | | | 0.4 | V | ADM1275-1 and ADM1275-3 $I_{LATCH} = 1\text{ mA}$ |
| | | | 1.5 | V | $I_{LATCH} = 5\text{ mA}$ |
| Leakage Current | | | 100 | nA | $V_{LATCH} \leq 2\text{ V}$; $\overline{\text{LATCH}}$ output high-Z |
| | | | 1 | μA | $V_{LATCH} = 20\text{ V}$; $\overline{\text{LATCH}}$ output high-Z |
| GPO1/ALERT1/CONV PIN (ADM1275-1 and ADM1275-2), ENABLE PIN (ADM1275-3) | | | | | |
| Output Low Voltage, V_{OL_GPO1} | | | 0.4 | V | $I_{GPO1} = 1\text{ mA}$ |
| | | | 1.5 | V | $I_{GPO1} = 5\text{ mA}$ |
| Leakage Current | | | 100 | nA | $V_{GPO1} \leq 2\text{ V}$; GPO output high-Z |
| | | | 1 | μA | $V_{GPO1} = 20\text{ V}$; GPO output high-Z |
| Input High Voltage, V_{IH} | 1.1 | | | V | |
| Input Low Voltage, V_{IL} | | | 0.8 | V | |
| GPO2/ALERT2 PIN | | | | | |
| Output Low Voltage, V_{OL_GPO2} | | | 0.4 | V | ADM1275-1 and ADM1275-3 $I_{GPO2} = 1\text{ mA}$ |
| | | | 1.5 | V | $I_{GPO2} = 5\text{ mA}$ |
| Leakage Current | | | 100 | nA | $V_{GPO2} \leq 2\text{ V}$; GPO output high-Z |
| | | | 1 | μA | $V_{GPO2} = 20\text{ V}$; GPO output high-Z |

| Parameter | Min | Typ | Max | Unit | Test Conditions/Comments |
|--|-----|------------|------------|---------------|---|
| PWRGD PIN | | | | | |
| Output Low Voltage, V_{OL_PWRGD} | | | 0.4 | V | $I_{PWRGD} = 1 \text{ mA}$ |
| | | | 1.5 | V | $I_{PWRGD} = 5 \text{ mA}$ |
| VCC That Guarantees Valid Output Leakage Current | 1 | | 100 | nA | $I_{SINK} = 100 \mu\text{A}$; $V_{OL_PWRGD} = 0.4 \text{ V}$ |
| | | | 1 | μA | $V_{PWRGD} \leq 2 \text{ V}$; PWRGD output high-Z $V_{PWRGD} = 20 \text{ V}$; PWRGD output high-Z |
| CURRENT AND VOLTAGE MONITORING | | | | | |
| Current Sense Absolute Error | | | | | 25 mV input range; 128 sample averaging (unless otherwise noted) |
| | | ± 0.2 | ± 0.7 | % | $V_{SENSE} = 20 \text{ mV}$; $V_{SENSE+} = 12 \text{ V}$; $T_A = 0^\circ\text{C}$ to 65°C |
| | | ± 0.08 | | % | $V_{SENSE} = 20 \text{ mV}$; $V_{SENSE+} = 12 \text{ V}$; $T_A = 25^\circ\text{C}$ |
| | | | ± 1.0 | % | $V_{SENSE} = 20 \text{ mV}$ |
| | | ± 0.08 | | % | $V_{SENSE} = 20 \text{ mV}$; $T_A = 25^\circ\text{C}$ |
| | | ± 0.2 | | % | $V_{SENSE} = 20 \text{ mV}$; $T_A = 0^\circ\text{C}$ to 65°C |
| | | | ± 1.0 | % | $V_{SENSE} = 20 \text{ mV}$; 16 sample averaging |
| | | ± 0.08 | | % | $V_{SENSE} = 20 \text{ mV}$; 16 sample averaging; $T_A = 25^\circ\text{C}$ |
| | | ± 0.2 | | % | $V_{SENSE} = 20 \text{ mV}$; 16 sample averaging; $T_A = 0^\circ\text{C}$ to 65°C |
| | | | ± 2.8 | % | $V_{SENSE} = 20 \text{ mV}$; 1 sample averaging |
| | | ± 0.09 | | % | $V_{SENSE} = 20 \text{ mV}$; 1 sample averaging; $T_A = 25^\circ\text{C}$ |
| | | ± 0.2 | | % | $V_{SENSE} = 20 \text{ mV}$; 1 sample averaging; $T_A = 0^\circ\text{C}$ to 65°C |
| | | | ± 0.7 | % | $V_{SENSE} = 25 \text{ mV}$; $V_{SENSE+} = 12 \text{ V}$ |
| | | ± 0.04 | | % | $V_{SENSE} = 25 \text{ mV}$; $V_{SENSE+} = 12 \text{ V}$; $T_A = 25^\circ\text{C}$ |
| | | ± 0.15 | | % | $V_{SENSE} = 25 \text{ mV}$; $V_{SENSE+} = 12 \text{ V}$; $T_A = 0^\circ\text{C}$ to 65°C |
| | | | ± 0.75 | % | $V_{SENSE} = 20 \text{ mV}$; $V_{SENSE+} = 12 \text{ V}$ |
| | | | ± 0.8 | % | $V_{SENSE} = 15 \text{ mV}$; $V_{SENSE+} = 12 \text{ V}$ |
| | | | ± 1.1 | % | $V_{SENSE} = 10 \text{ mV}$; $V_{SENSE+} = 12 \text{ V}$ |
| | | | ± 2.0 | % | $V_{SENSE} = 5 \text{ mV}$; $V_{SENSE+} = 12 \text{ V}$ |
| | | | ± 4.3 | % | $V_{SENSE} = 2.5 \text{ mV}$; $V_{SENSE+} = 12 \text{ V}$ |
| SENSE+/VOUT Absolute Error | | | ± 1.0 | % | Low input range; input voltage $\geq 3 \text{ V}$ |
| | | | ± 1.0 | % | High input range; input voltage $\geq 10 \text{ V}$ |
| ADC Conversion Time | | 250 | 305 | μs | 1 sample of voltage and current; from command received to valid data in register |
| | | 4000 | 4880 | μs | 16 samples of voltage and current averaged; from command received to valid data in register |
| ADR PIN | | | | | |
| Address Set to 00 | 0 | | 0.8 | V | Connect to GND |
| Input Current for Address 00 | -40 | -22 | | μA | $V_{ADR} = 0 \text{ V}$ to 0.8 V |
| Address Set to 01 | 135 | 150 | 165 | k Ω | Resistor to GND |
| Address Set to 10 | -1 | | +1 | μA | No connect state; maximum leakage current allowed |
| Address Set to 11 | 2 | | | V | Connect to VCAP |
| Input Current for Address 11 | | 3 | 10 | μA | $V_{ADR} = 2.0 \text{ V}$ to VCAP; must not exceed the maximum allowable current draw from VCAP |
| SERIAL BUS DIGITAL INPUTS (SDA, SCL) | | | | | |
| Input High Voltage, V_{IH} | 1.1 | | | V | |
| Input Low Voltage, V_{IL} | | | 0.8 | V | |
| Output Low Voltage, V_{OL} | | | 0.4 | V | $I_{OL} = 4 \text{ mA}$ |
| Input Leakage, I_{LEAK_PIN} | -10 | | +10 | μA | |
| | -5 | | +5 | μA | Device is not powered |
| Nominal Bus Voltage, V_{DD} | 2.7 | | 5.5 | V | 3 V to 5 V $\pm 10\%$ |
| Capacitance for SDA, SCL Pin, C_{PIN} | | 5 | | pF | |
| Input Glitch Filter, t_{SP} | 0 | | 50 | ns | |

SERIAL BUS TIMING CHARACTERISTICS

$t_R = (V_{IL(MAX)} - 0.15)$ to $(V_{IH3V3} + 0.15)$ and $t_F = 0.9V_{DD}$ to $(V_{IL(MAX)} - 0.15)$; where $V_{IH3V3} = 2.1$ V and $V_{DD} = 3.3$ V.

Table 2.

| Parameter | Description | Min | Typ | Max | Unit | Test Conditions/Comments |
|--------------|--------------------|-----|-----|-----|---------|---|
| f_{SCLK} | Clock frequency | | | 400 | kHz | |
| t_{BUF} | Bus free time | 1.3 | | | μ s | Following the stop condition of a read transaction |
| | | 4.7 | | | μ s | Following the stop condition of a write transaction |
| $t_{HD,STA}$ | Start hold time | 0.6 | | | μ s | |
| $t_{SU,STA}$ | Start setup time | 0.6 | | | μ s | |
| $t_{SU,STO}$ | Stop setup time | 0.6 | | | μ s | |
| $t_{HD,DAT}$ | SDA hold time | 300 | | 900 | ns | |
| $t_{SU,DAT}$ | SDA setup time | 100 | | | ns | |
| t_{LOW} | SCL low time | 1.3 | | | μ s | |
| t_{HIGH} | SCL high time | 0.6 | | | μ s | |
| t_R^1 | SCL, SDA rise time | 20 | | 300 | ns | |
| t_F^1 | SCL, SDA fall time | 20 | | 300 | ns | |

¹ The interface is specified to meet the I²C fast mode requirements. It is also capable of receiving signals complying with the I²C standard mode. The ADM1275 is guaranteed by design to accept edges as fast as 10 ns.

Timing Diagram

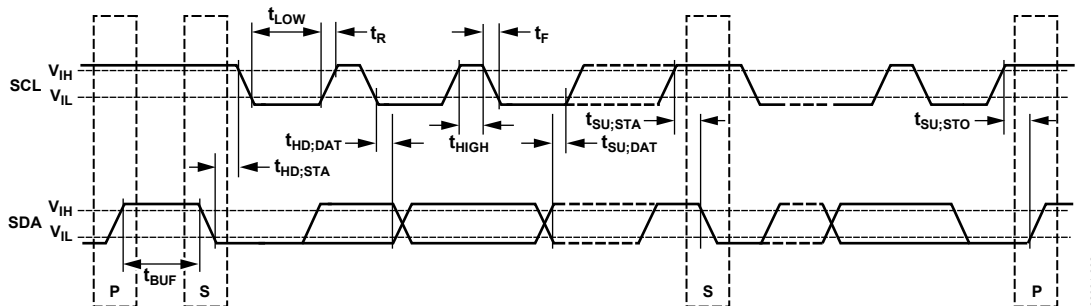

Figure 2. Serial Bus Timing Diagram

08931-002

ABSOLUTE MAXIMUM RATINGS

Table 3.

| Parameter | Rating |
|---|------------------------|
| VCC Pin | −0.3 V to +25 V |
| UV Pin | −0.3 V to +4 V |
| OV Pin | −0.3 V to +4 V |
| SS Pin | −0.3 V to VCAP + 0.3 V |
| TIMER Pin | −0.3 V to VCAP + 0.3 V |
| VCAP Pin | −0.3 V to +4 V |
| ISET Pin | −0.3 V to VCAP + 0.3 V |
| LATCH Pin | −0.3 V to +25 V |
| SCL Pin | −0.3 V to +6.5 V |
| SDA Pin | −0.3 V to +6.5 V |
| ADR Pin | −0.3 V to VCAP + 0.3 V |
| GPO1/ALERT1/CONV Pin, ENABLE Pin | −0.3 V to +25 V |
| GPO2/ALERT2 Pin | −0.3 V to +25 V |
| PWRGD Pin | −0.3 V to +25 V |
| FLB Pin | −0.3 V to +25 V |
| VOUT Pin | −0.3 V to +25 V |
| GATE Pin (Internal Supply Only) ¹ | −0.3 V to +36 V |
| SENSE+ Pin | −0.3 V to +25 V |
| SENSE− Pin | −0.3 V to +25 V |
| V _{SENSE} (V _{SENSE+} − V _{SENSE−}) | ±0.3 V |
| Continuous Current into Any Pin | ±10 mA |
| Storage Temperature Range | −65°C to +125°C |
| Operating Temperature Range | −40°C to +85°C |
| Lead Temperature, Soldering (10 sec) | 300°C |
| Junction Temperature | 150°C |

¹ The GATE pin has internal clamping circuits to prevent the GATE pin voltage from exceeding the maximum ratings of a MOSFET with V_{GS}MAX = 20 V and internal process limits. Applying a voltage source to this pin externally may cause irreversible damage.

Stresses at or above those listed under Absolute Maximum Ratings may cause permanent damage to the product. This is a stress rating only; functional operation of the product at these or any other conditions above those indicated in the operational section of this specification is not implied. Operation beyond the maximum operating conditions for extended periods may affect product reliability.

THERMAL CHARACTERISTICS

θ_{JA} is specified for the worst-case conditions, that is, a device soldered in a circuit board for surface-mount packages.

Table 4. Thermal Resistance

| Package Type | θ_{JA} | Unit |
|-------------------------|---------------|------|
| 16-lead QSOP (RQ-16) | 150 | °C/W |
| 20-lead QSOP (RQ-20) | 126 | °C/W |
| 20-lead LFCSP (CP-20-9) | 30.4 | °C/W |

ESD CAUTION



ESD (electrostatic discharge) sensitive device. Charged devices and circuit boards can discharge without detection. Although this product features patented or proprietary protection circuitry, damage may occur on devices subjected to high energy ESD. Therefore, proper ESD precautions should be taken to avoid performance degradation or loss of functionality.

PIN CONFIGURATIONS AND FUNCTION DESCRIPTIONS

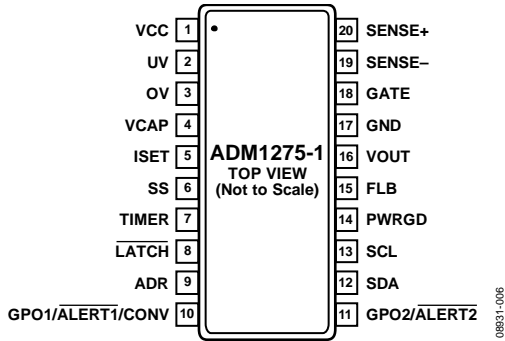
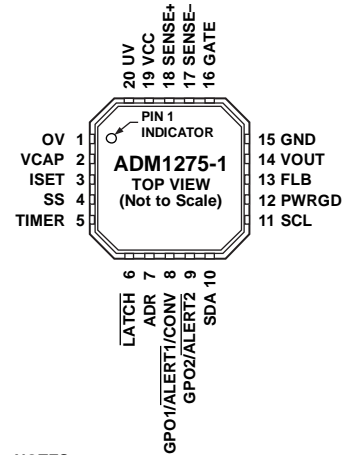

Figure 3. ADM1275-1 Pin Configuration, QSOP



NOTES
 1. SOLDER THE EXPOSED PADDLE TO THE BOARD TO IMPROVE THERMAL DISSIPATION. THE EXPOSED PADDLE CAN BE CONNECTED TO GROUND.

Figure 4. ADM1275-1 Pin Configuration, LFCSP

Table 5. ADM1275-1 Pin Function Descriptions

| Pin No. | | Mnemonic | Description |
|---------|-------|----------------------|---|
| QSOP | LFCSP | | |
| 1 | 19 | VCC | Positive Supply Input Pin. An undervoltage lockout (UVLO) circuit resets the device when a low supply voltage is detected. GATE is held low when the supply is below UVLO. During normal operation, this pin should remain greater than or equal to SENSE+ to ensure that specifications are adhered to. No sequencing is required. |
| 2 | 20 | UV | Undervoltage Input Pin. An external resistor divider is used from the supply to this pin to allow an internal comparator to detect whether the supply is under the UV limit. |
| 3 | 1 | OV | Overshoot Input Pin. An external resistor divider is used from the supply to this pin to allow an internal comparator to detect whether the supply is above the OV limit. |
| 4 | 2 | VCAP | Internal Regulated Supply. A capacitor with a value of 1 μ F or greater should be placed on this pin to maintain good accuracy. This pin can be used as a reference to program the ISET pin voltage. |
| 5 | 3 | ISET | This pin allows the current limit threshold to be programmed. The default limit is set when this pin is connected directly to VCAP. To achieve a user-defined sense voltage, the current limit can be adjusted using a resistor divider from VCAP. An external reference can also be used. |
| 6 | 4 | SS | Soft Start Pin. A capacitor is used on this pin to set the soft start ramp profile. The voltage on the SS pin controls the current sense voltage limit, which controls the inrush current profile. |
| 7 | 5 | TIMER | Timer Pin. An external capacitor, C_{TIMER} , sets an initial timing cycle delay and a fault delay. The GATE pin is pulled low when the voltage on the TIMER pin exceeds the upper threshold. |
| 8 | 6 | LATCH | Signals that the device is latching off after an overcurrent fault. The device can be configured for automatic retry after latch-off by connecting this pin directly back to the UV pin. |
| 9 | 7 | ADR | PMBus Address Pin. This pin can be tied to GND, tied to VCAP, left floating, or tied low through a resistor to set four different PMBus addresses (see the Device Addressing section). |
| 10 | 8 | GPO1/ALERT1/ CONV | General-Purpose Digital Output (GPO1). Alert (ALERT1). This pin can be configured to generate an alert signal when one or more fault or warning conditions are detected. Conversion (CONV). This pin can be used as an input signal to control when a power monitor ADC sampling cycle begins. |
| 11 | 9 | GPO2/ALERT2 | At power-up, this pin defaults to a high impedance state. There is no internal pull-up on this pin. General-Purpose Digital Output (GPO2). Alert (ALERT2). This pin can be configured to generate an alert signal when one or more fault or warning conditions are detected. At power-up, this pin indicates the FET health mode by default. There is no internal pull-up on this pin. |

| Pin No. | | Mnemonic | Description |
|---------|-------|----------|--|
| QSOP | LFCSP | | |
| 12 | 10 | SDA | Serial Data Input/Output Pin. Open-drain input/output. Requires an external resistive pull-up. |
| 13 | 11 | SCL | Serial Clock Pin. Open-drain input. Requires an external resistive pull-up. |
| 14 | 12 | PWRGD | Power-Good Signal. Used to indicate that the supply is within tolerance. This signal is based on the voltage present on the FLB pin. |
| 15 | 13 | FLB | Foldback Pin. A foldback resistor divider is placed from the source of the FET to this pin. Foldback is used to reduce the current limit when the source voltage drops. The foldback feature ensures that the power through the FET is not increased beyond the SOA limits. |
| 16 | 14 | VOUT | This pin is used to read back the output voltage using the internal ADC. A 1 k Ω resistor should be inserted in series between the source of a FET and the VOOUT pin. |
| 17 | 15 | GND | Chip Ground Pin. |
| 18 | 16 | GATE | Gate Output Pin. This pin is the high-side gate drive of an external N-channel FET. This pin is driven by the FET drive controller, which uses a charge pump to provide a pull-up current to charge the FET gate pin. The FET drive controller regulates to a maximum load current by regulating the GATE pin. GATE is held low when the supply is below UVLO. |
| 19 | 17 | SENSE- | Negative Current Sense Input Pin. A sense resistor between the SENSE+ pin and the SENSE- pin sets the analog current limit. The hot-swap operation of the ADM1275 controls the external FET gate to maintain the sense voltage ($V_{SENSE+} - V_{SENSE-}$). This pin also connects to the FET drain pin. |
| 20 | 18 | SENSE+ | Positive Current Sense Input Pin. This pin connects to the main supply input. A sense resistor between the SENSE+ pin and the SENSE- pin sets the analog current limit. The hot-swap operation of the ADM1275 controls the external FET gate to maintain the sense voltage ($V_{SENSE+} - V_{SENSE-}$). This pin is also used to measure the supply input voltage using the ADC. |
| N/A | EP | EPAD | Exposed Paddle on Underside of LFCSP. Solder the exposed paddle to the board to improve thermal dissipation. The exposed paddle can be connected to ground. |

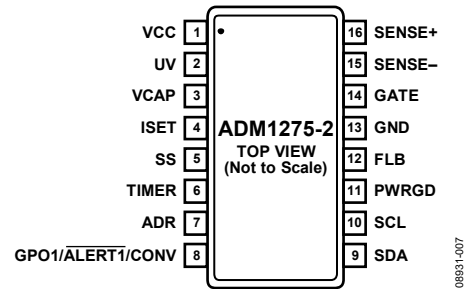

Figure 5. ADM1275-2 Pin Configuration

Table 6. ADM1275-2 Pin Function Descriptions

| Pin No. | Mnemonic | Description |
|---------|---------------------------|---|
| 1 | VCC | Positive Supply Input Pin. An undervoltage lockout (UVLO) circuit resets the device when a low supply voltage is detected. GATE is held low when the supply is below UVLO. During normal operation, this pin should remain greater than or equal to SENSE+ to ensure that specifications are adhered to. No sequencing is required. |
| 2 | UV | Undervoltage Input Pin. An external resistor divider is used from the supply to this pin to allow an internal comparator to detect whether the supply is under the UV limit. |
| 3 | VCAP | Internal Regulated Supply. A capacitor with a value of 1 μ F or greater should be placed on this pin to maintain good accuracy. This pin can be used as a reference to program the ISET pin voltage. |
| 4 | ISET | This pin allows the current limit threshold to be programmed. The default limit is set when this pin is connected directly to VCAP. To achieve a user-defined sense voltage, the current limit can be adjusted using a resistor divider from VCAP. An external reference can also be used. |
| 5 | SS | Soft Start Pin. A capacitor is used on this pin to set the soft start ramp profile. The voltage on the SS pin controls the current sense voltage limit, which controls the inrush current profile. |
| 6 | TIMER | Timer Pin. An external capacitor, C_{TIMER} , sets an initial timing cycle delay and a fault delay. The GATE pin is pulled low when the voltage on the TIMER pin exceeds the upper threshold. |
| 7 | ADR | PMBus Address Pin. This pin can be tied to GND, tied to VCAP, left floating, or tied low through a resistor to set four different PMBus addresses (see the Device Addressing section). |
| 8 | GPO1/ <u>ALERT1</u> /CONV | General-Purpose Digital Output (GPO1). Alert (ALERT1). This pin can be configured to generate an alert signal when one or more fault or warning conditions are detected. Conversion (CONV). This pin can be used as an input signal to control when a power monitor ADC sampling cycle begins. At power-up, this pin defaults to a high impedance state. There is no internal pull-up on this pin. |
| 9 | SDA | Serial Data Input/Output Pin. Open-drain input/output. Requires an external resistive pull-up. |
| 10 | SCL | Serial Clock Pin. Open-drain input. Requires an external resistive pull-up. |
| 11 | PWRGD | Power-Good Signal. Used to indicate that the supply is within tolerance. This signal is based on the voltage present on the FLB pin. |
| 12 | FLB | Foldback Pin. A foldback resistor divider is placed from the source of the FET to this pin. Foldback is used to reduce the current limit when the source voltage drops. The foldback feature ensures that the power through the FET is not increased beyond the SOA limits. |
| 13 | GND | Chip Ground Pin. |
| 14 | GATE | Gate Output Pin. This pin is the high-side gate drive of an external N-channel FET. This pin is driven by the FET drive controller, which uses a charge pump to provide a pull-up current to charge the FET gate pin. The FET drive controller regulates to a maximum load current by regulating the GATE pin. GATE is held low when the supply is below UVLO. |
| 15 | SENSE- | Negative Current Sense Input Pin. A sense resistor between the SENSE+ pin and the SENSE- pin sets the analog current limit. The hot-swap operation of the ADM1275 controls the external FET gate to maintain the sense voltage ($V_{SENSE+} - V_{SENSE-}$). This pin also connects to the FET drain pin. |
| 16 | SENSE+ | Positive Current Sense Input Pin. This pin connects to the main supply input. A sense resistor between the SENSE+ pin and the SENSE- pin sets the analog current limit. The hot-swap operation of the ADM1275 controls the external FET gate to maintain the sense voltage ($V_{SENSE+} - V_{SENSE-}$). This pin is also used to measure the supply input voltage using the ADC. |

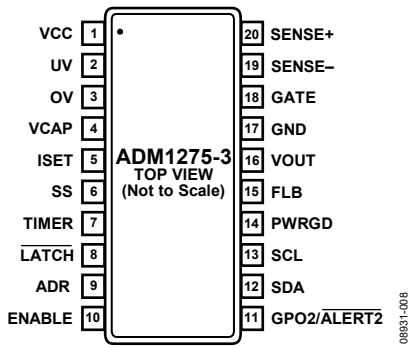
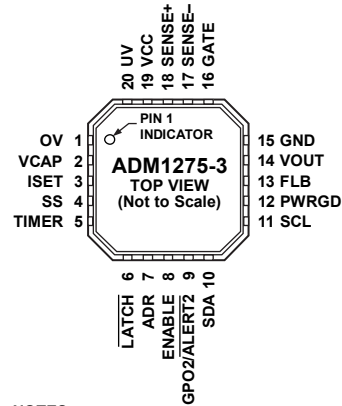

Figure 6. ADM1275-3 Pin Configuration, QSOP



NOTES

1. SOLDER THE EXPOSED PADDLE TO THE BOARD TO IMPROVE THERMAL DISSIPATION. THE EXPOSED PADDLE CAN BE CONNECTED TO GROUND.

Figure 7. ADM1275-3 Pin Configuration, LFCSP

Table 7. ADM1275-3 Pin Function Descriptions

| Pin No. | | Mnemonic | Description |
|---------|-------|-------------|---|
| QSOP | LFCSP | | |
| 1 | 19 | VCC | Positive Supply Input Pin. An undervoltage lockout (UVLO) circuit resets the device when a low supply voltage is detected. GATE is held low when the supply is below UVLO. During normal operation, this pin should remain greater than or equal to SENSE+ to ensure that specifications are adhered to. No sequencing is required. |
| 2 | 20 | UV | Undervoltage Input Pin. An external resistor divider is used from the supply to this pin to allow an internal comparator to detect whether the supply is under the UV limit. |
| 3 | 1 | OV | Overvoltage Input Pin. An external resistor divider is used from the supply to this pin to allow an internal comparator to detect whether the supply is above the OV limit. |
| 4 | 2 | VCAP | Internal Regulated Supply. A capacitor with a value of 1 μ F or greater should be placed on this pin to maintain good accuracy. This pin can be used as a reference to program the ISET pin voltage. |
| 5 | 3 | ISET | This pin allows the current limit threshold to be programmed. The default limit is set when this pin is connected directly to VCAP. To achieve a user-defined sense voltage, the current limit can be adjusted using a resistor divider from VCAP. An external reference can also be used. |
| 6 | 4 | SS | Soft Start Pin. A capacitor is used on this pin to set the soft start ramp profile. The voltage on the SS pin controls the current sense voltage limit, which controls the inrush current profile. |
| 7 | 5 | TIMER | Timer Pin. An external capacitor, C_{TIMER} , sets an initial timing cycle delay and a fault delay. The GATE pin is pulled low when the voltage on the TIMER pin exceeds the upper threshold. |
| 8 | 6 | LATCH | Signals that the device is latching off after an overcurrent fault. The device can be configured for automatic retry after latch-off by connecting this pin directly back to the UV pin. |
| 9 | 7 | ADR | PMBus Address Pin. This pin can be tied to GND, tied to VCAP, left floating, or tied low through a resistor to set four different PMBus addresses (see the Device Addressing section). |
| 10 | 8 | ENABLE | Digital Logic Input. This input must be high to allow the ADM1275-3 hot-swap controller to begin a power-up sequence. If this pin is held low, the ADM1275-3 is prevented from powering up. There is no internal pull-up on this pin. |
| 11 | 9 | GPO2/ALERT2 | General-Purpose Digital Output (GPO2). Alert (ALERT2). This pin can be configured to generate an alert signal when one or more fault or warning conditions are detected. At power-up, this pin indicates the FET health mode by default. There is no internal pull-up on this pin. |
| 12 | 10 | SDA | Serial Data Input/Output Pin. Open-drain input/output. Requires an external resistive pull-up. |
| 13 | 11 | SCL | Serial Clock Pin. Open-drain input. Requires an external resistive pull-up. |
| 14 | 12 | PWRGD | Power-Good Signal. Used to indicate that the supply is within tolerance. This signal is based on the voltage present on the FLB pin. |
| 15 | 13 | FLB | Foldback Pin. A foldback resistor divider is placed from the source of the FET to this pin. Foldback is used to reduce the current limit when the source voltage drops. The foldback feature ensures that the power through the FET is not increased beyond the SOA limits. |

| Pin No. | | Mnemonic | Description |
|---------|-------|----------|--|
| QSOP | LFCSP | | |
| 16 | 14 | VOUT | This pin is used to read back the output voltage using the internal ADC. A 1 k Ω resistor should be inserted in series between the source of a FET and the VOOUT pin. |
| 17 | 15 | GND | Chip Ground Pin. |
| 18 | 16 | GATE | Gate Output Pin. This pin is the high-side gate drive of an external N-channel FET. This pin is driven by the FET drive controller, which uses a charge pump to provide a pull-up current to charge the FET gate pin. The FET drive controller regulates to a maximum load current by regulating the GATE pin. GATE is held low when the supply is below UVLO. |
| 19 | 17 | SENSE- | Negative Current Sense Input Pin. A sense resistor between the SENSE+ pin and the SENSE- pin sets the analog current limit. The hot-swap operation of the ADM1275 controls the external FET gate to maintain the sense voltage ($V_{\text{SENSE+}} - V_{\text{SENSE-}}$). This pin also connects to the FET drain pin. |
| 20 | 18 | SENSE+ | Positive Current Sense Input Pin. This pin connects to the main supply input. A sense resistor between the SENSE+ pin and the SENSE- pin sets the analog current limit. The hot-swap operation of the ADM1275 controls the external FET gate to maintain the sense voltage ($V_{\text{SENSE+}} - V_{\text{SENSE-}}$). This pin is also used to measure the supply input voltage using the ADC. |
| N/A | EP | EPAD | Exposed Paddle on Underside of LFCSP. Solder the exposed paddle to the board to improve thermal dissipation. The exposed paddle can be connected to ground. |

TYPICAL PERFORMANCE CHARACTERISTICS

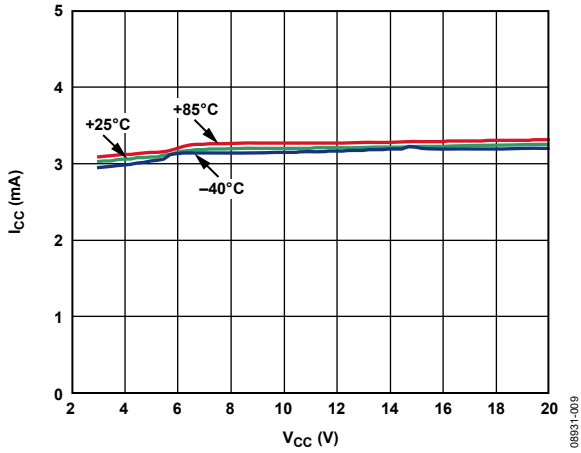

Figure 8. Supply Current (I_{CC}) vs. Supply Voltage (V_{CC})

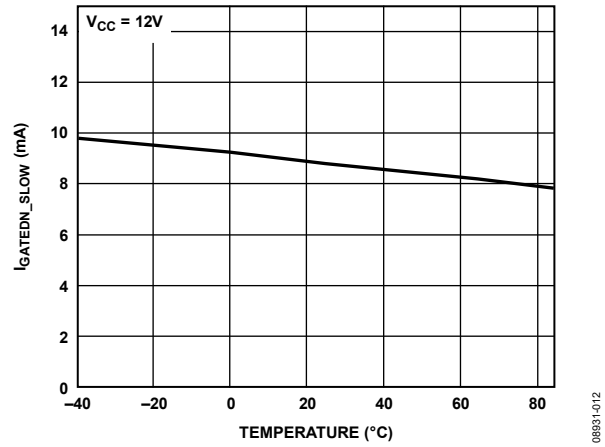

Figure 11. Gate Pull-Down Current (I_{GATEDN_SLOW}) vs. Temperature

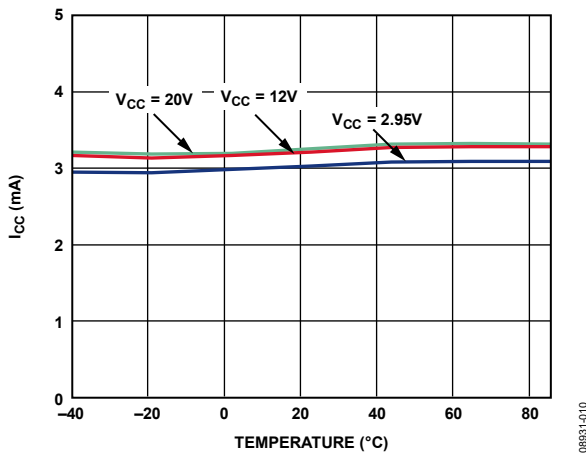

Figure 9. Supply Current (I_{CC}) vs. Temperature

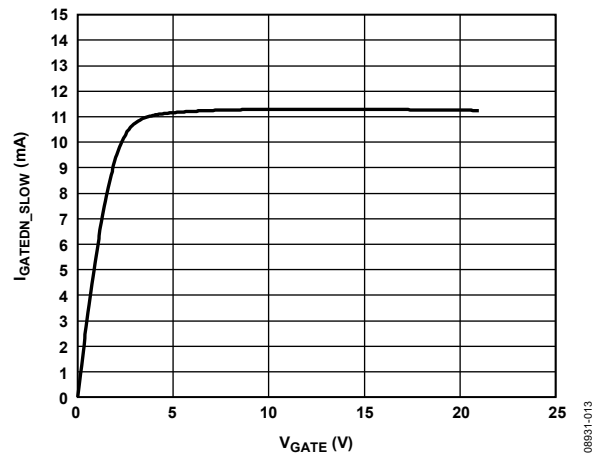

Figure 12. Gate Pull-Down Current (I_{GATEDN_SLOW}) vs. Gate Voltage (V_{GATE})

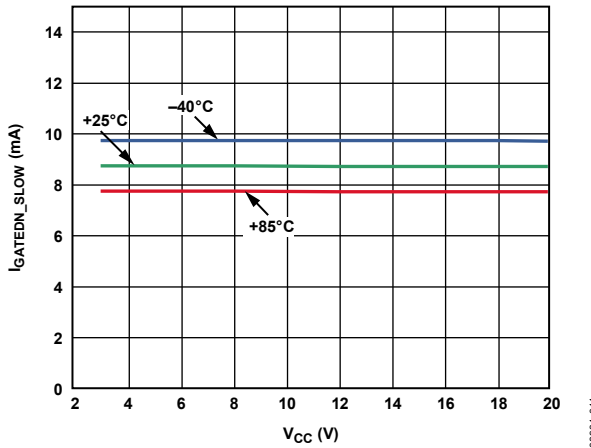

Figure 10. Gate Pull-Down Current (I_{GATEDN_SLOW}) vs. Supply Voltage (V_{CC})

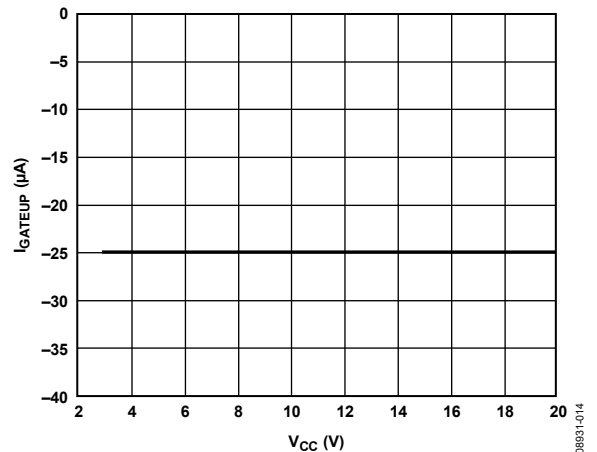

Figure 13. Gate Pull-Up Current (I_{GATEUP}) vs. Supply Voltage (V_{CC})

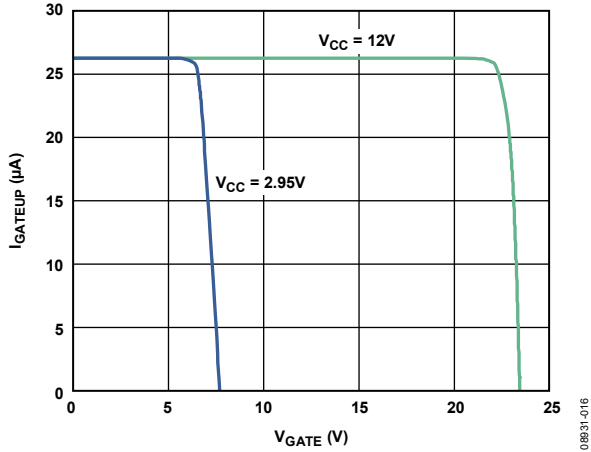

Figure 14. Gate Pull-Up Current (I_{GATEUP}) vs. Gate Voltage (V_{GATE})

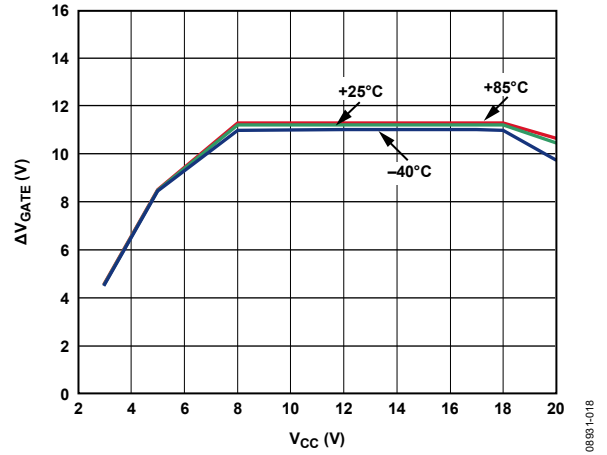

Figure 17. Gate Drive Voltage (ΔV_{GATE}) vs. Supply Voltage (V_{CC}), 5 μA Load

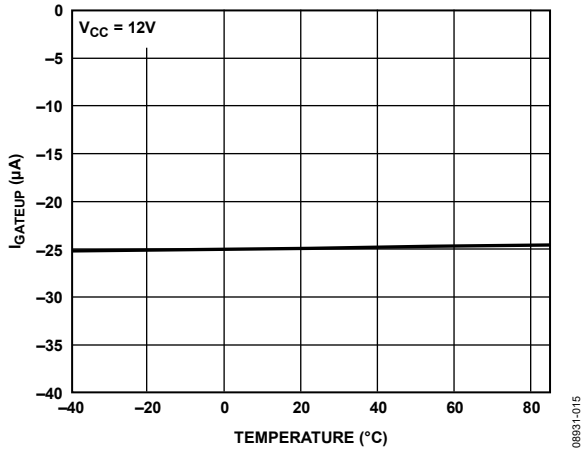

Figure 15. Gate Pull-Up Current (I_{GATEUP}) vs. Temperature

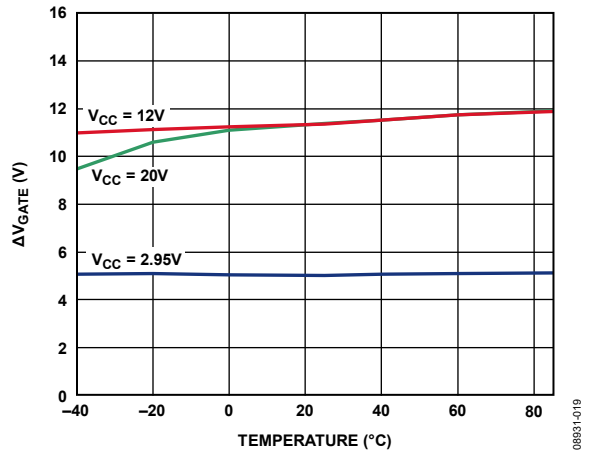

Figure 18. Gate Drive Voltage (ΔV_{GATE}) vs. Temperature, No Load

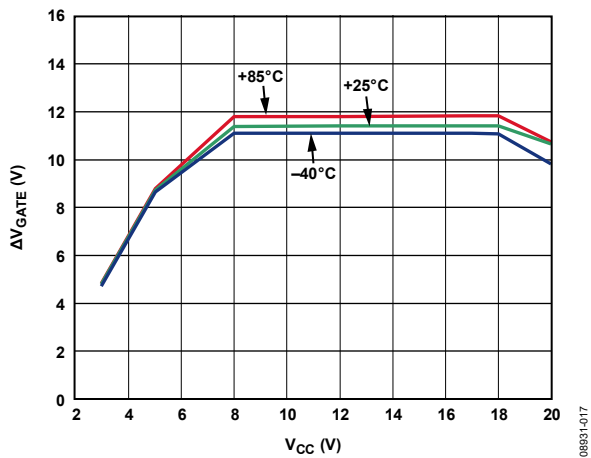

Figure 16. Gate Drive Voltage (ΔV_{GATE}) vs. Supply Voltage (V_{CC}), No Load

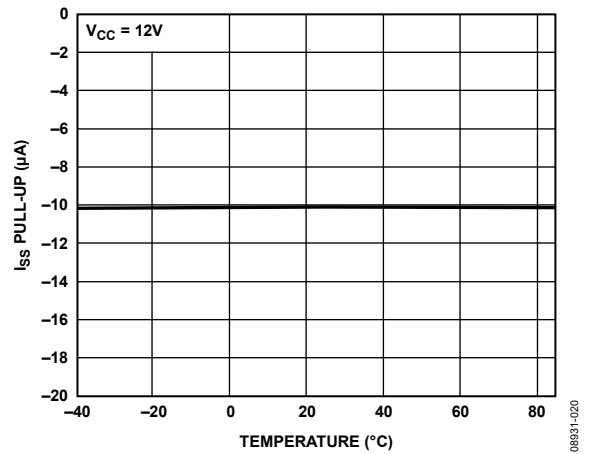

Figure 19. Soft Start Pull-Up Current (I_{SS}) vs. Temperature

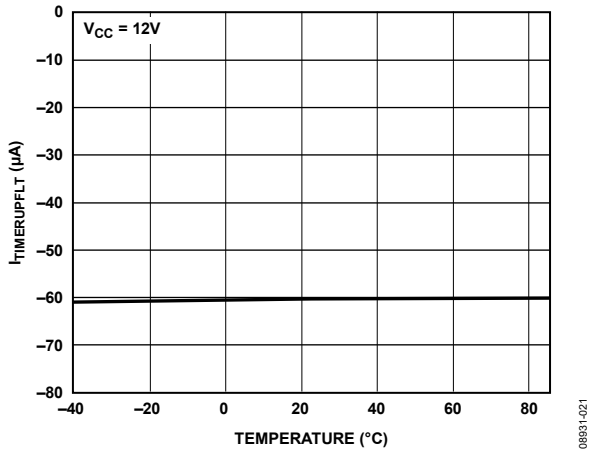

Figure 20. Timer Pull-Up Current, Overcurrent Fault ($I_{TIMERUPFLT}$) vs. Temperature

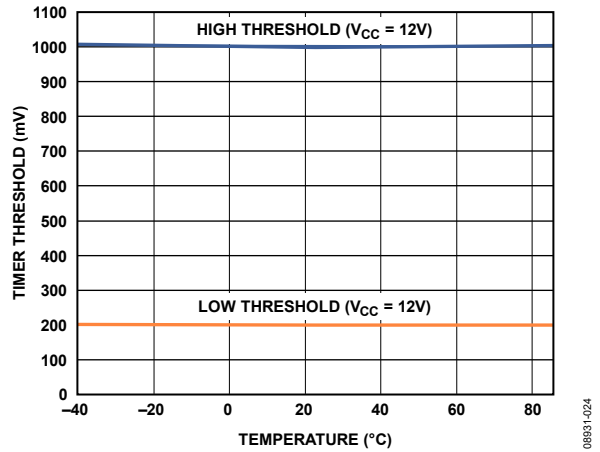

Figure 23. Timer Thresholds vs. Temperature

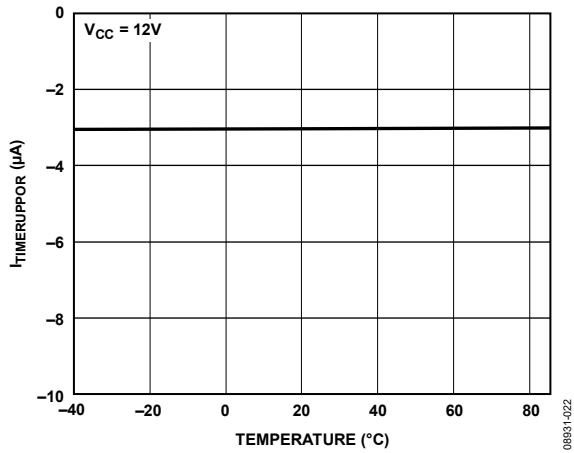

Figure 21. Timer Pull-Up Current, Power-On Reset ($I_{TIMERUPPOR}$) vs. Temperature

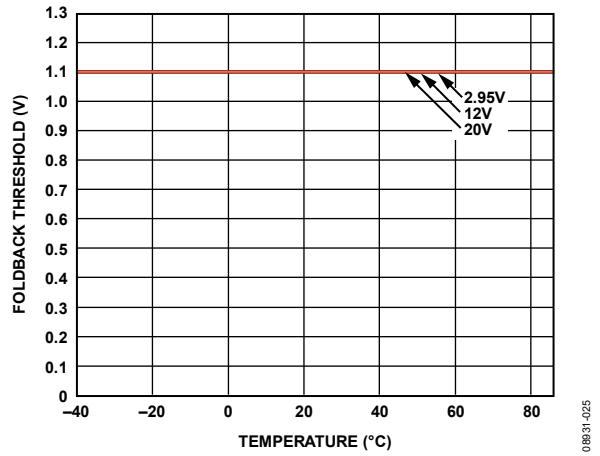

Figure 24. Foldback Threshold vs. Temperature

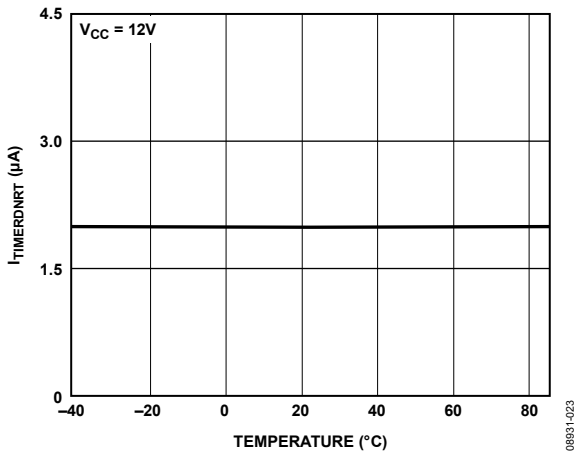

Figure 22. Timer Pull-Down Current, Retry ($I_{TIMERDNRT}$) vs. Temperature

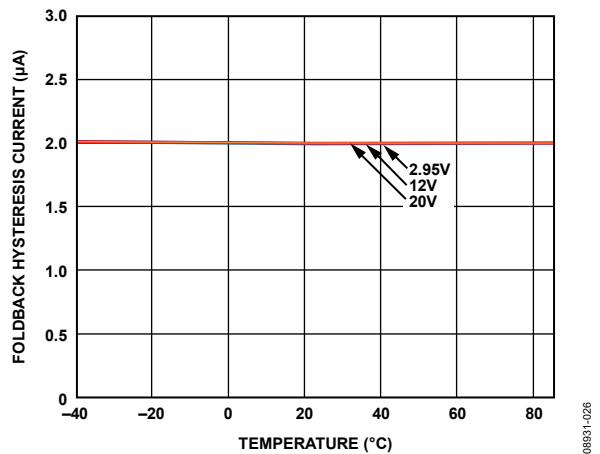

Figure 25. Foldback Hysteresis Current vs. Temperature

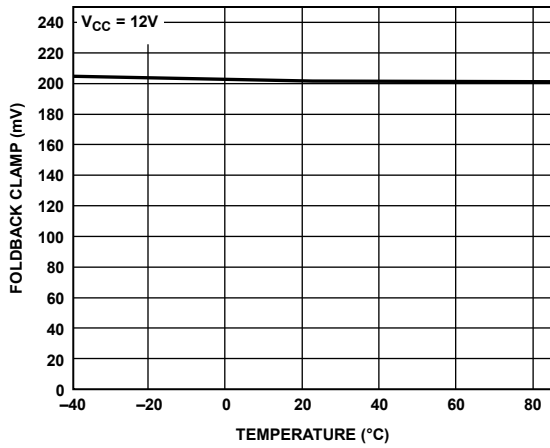

Figure 26. Foldback Clamp vs. Temperature

08931-027

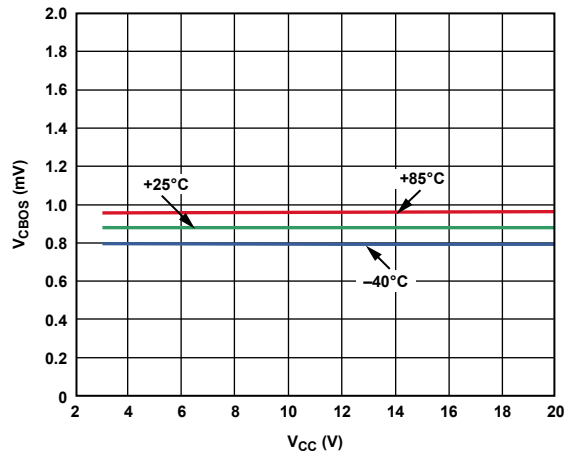

Figure 29. Circuit Breaker Offset (V_{CBOs}) vs. Supply Voltage (V_{CC})

08931-130

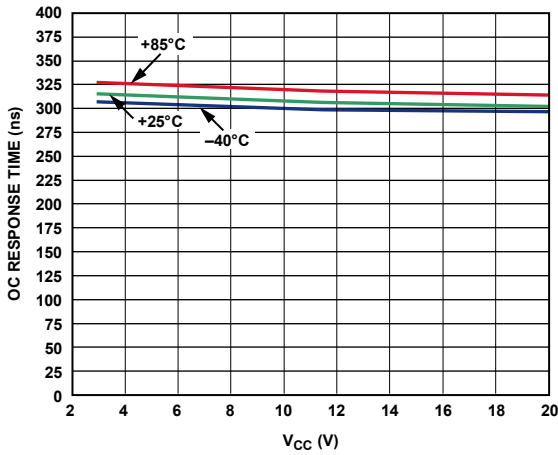

Figure 27. Severe Overcurrent Response Time vs. Supply Voltage (V_{CC}), $V_{ISET} = 0.25 V$

08931-128

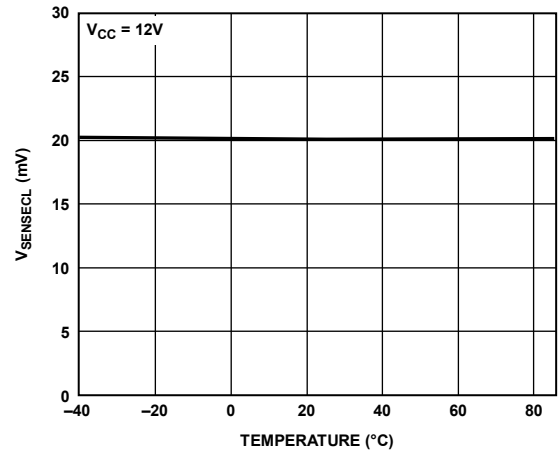

Figure 30. Hot-Swap Sense Voltage Current Limit ($V_{SENSECL}$) vs. Temperature

08931-131

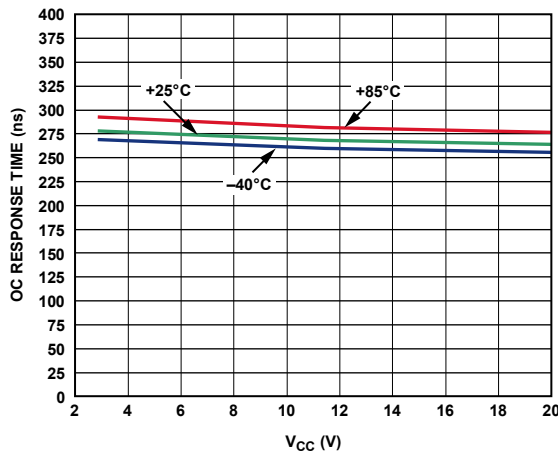

Figure 28. Severe Overcurrent Response Time vs. Supply Voltage (V_{CC}), $V_{ISET} = 1 V$

08931-129

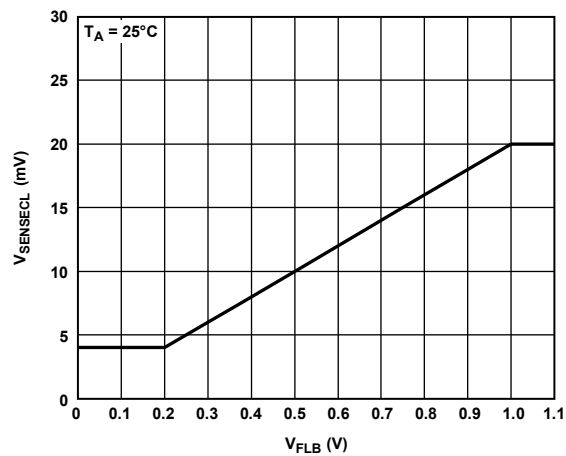

Figure 31. Hot-Swap Sense Voltage Current Limit ($V_{SENSECL}$) vs. Foldback Voltage (V_{FLB})

08931-132

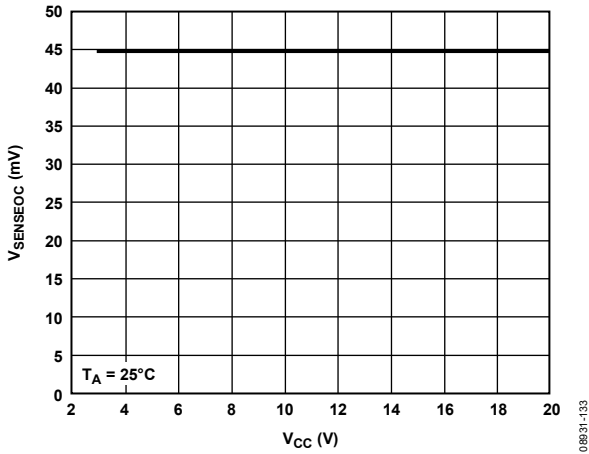

Figure 32. Severe Overcurrent Voltage Threshold ($V_{SENSEOC}$) vs. Supply Voltage (V_{CC}), $V_{ISET} = V_{VCAP}$

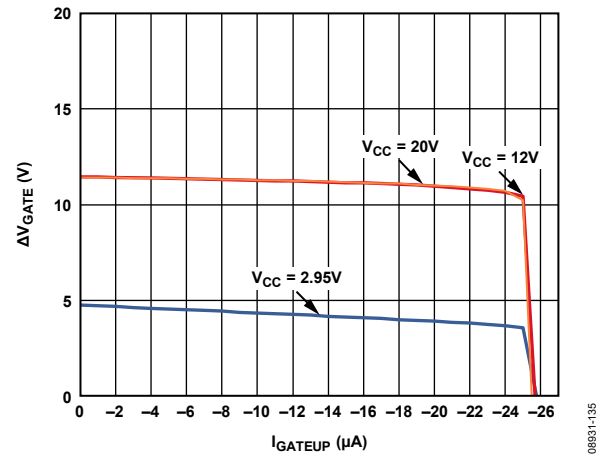

Figure 35. Gate Drive Voltage (ΔV_{GATE}) vs. Gate Pull-Up Current (I_{GATEUP})

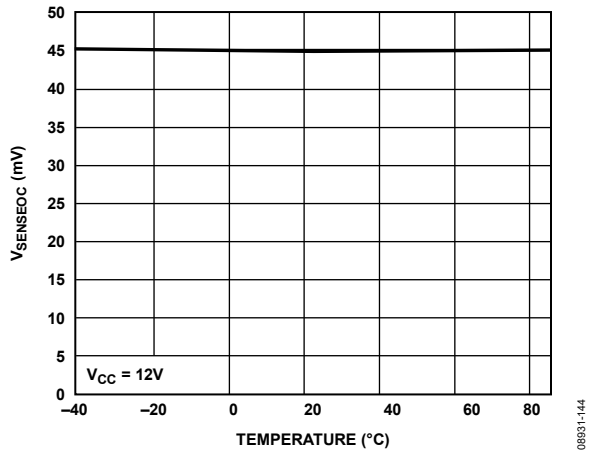

Figure 33. Severe Overcurrent Voltage Threshold ($V_{SENSEOC}$) vs. Temperature, $V_{ISET} = V_{VCAP}$

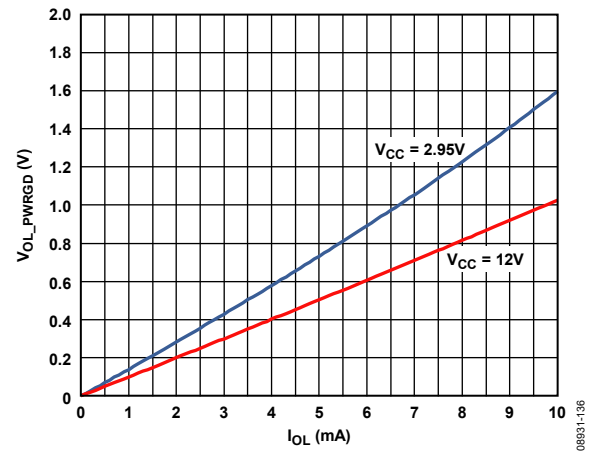

Figure 36. PWRGD Pin, V_{OL_PWRGD} vs. I_{OL}

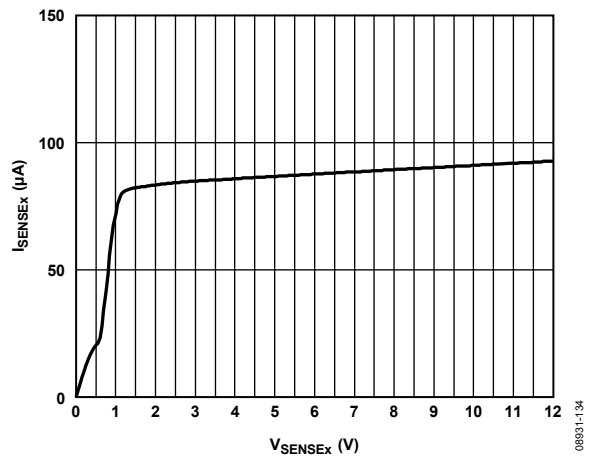

Figure 34. SENSE+ / SENSE- Input Current (I_{SENSEx}) vs. Voltage (V_{SENSEx})

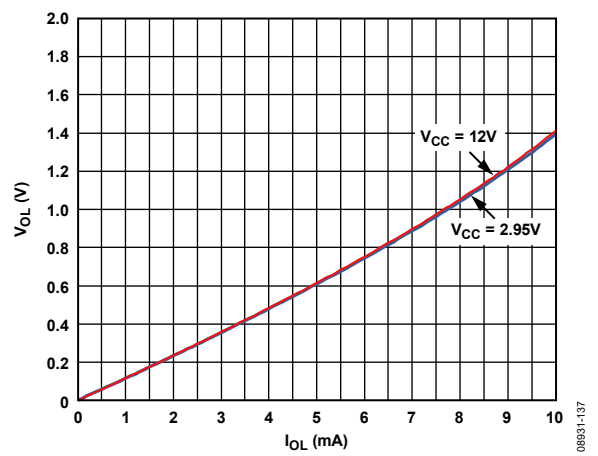

Figure 37. $\overline{\text{LATCH}}$ and $\overline{\text{GPOx}} / \overline{\text{ALERTx}}$ Digital Outputs, V_{OL} vs. I_{OL}

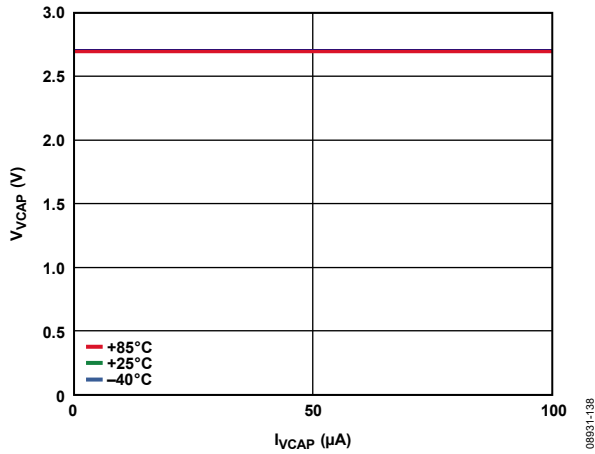

Figure 38. VCAP Voltage (V_{VCAP}) vs. VCAP Load (I_{VCAP})

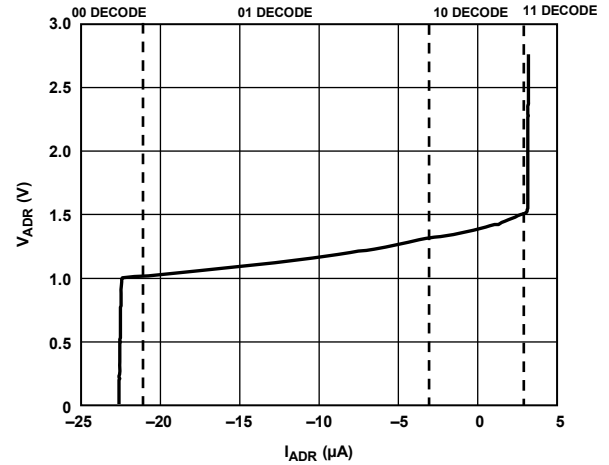

Figure 41. ADR Pin Voltage (V_{ADR}) vs. Current (I_{ADR})

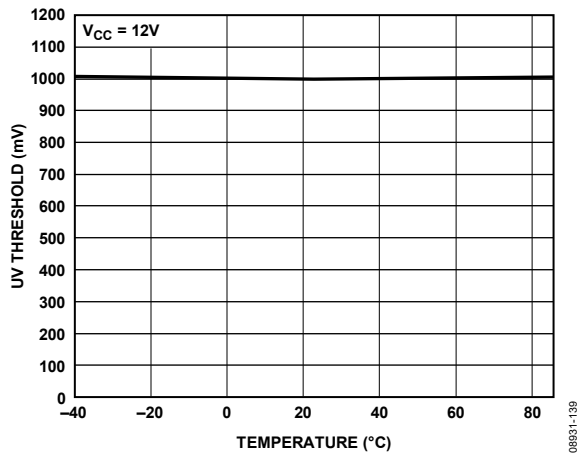

Figure 39. UV Threshold (UV_{TH}) vs. Temperature

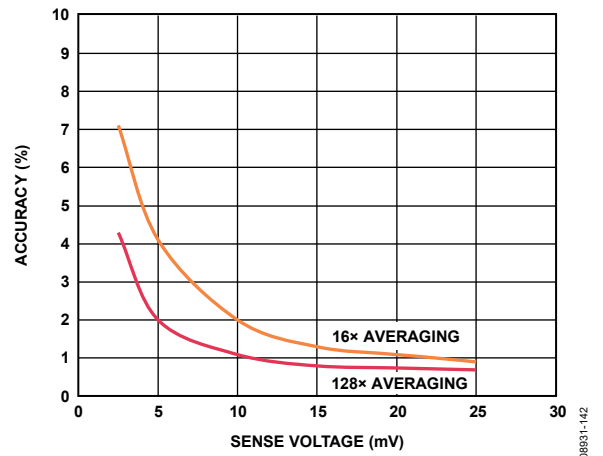

Figure 42. Worst-Case Current Sense Power Monitor Error vs. Current Sense Voltage (V_{SENSE}), 0°C to 65°C, $V_{SENSE+} = 12V$

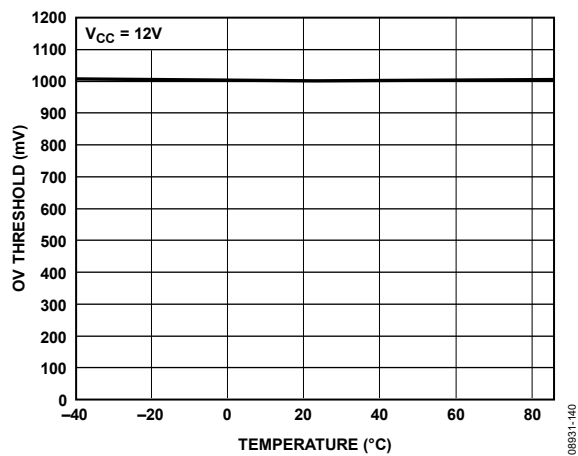

Figure 40. OV Threshold (OV_{TH}) vs. Temperature

FUNCTIONAL BLOCK DIAGRAMS

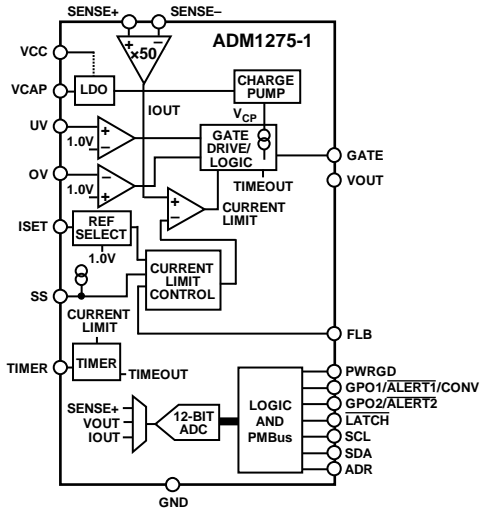

Figure 43. ADM1275-1 Functional Block Diagram

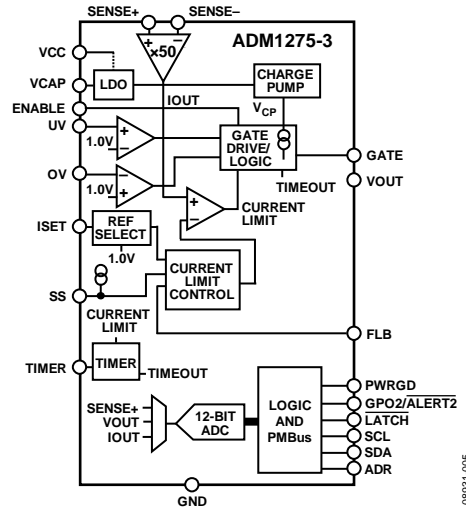

Figure 45. ADM1275-3 Functional Block Diagram

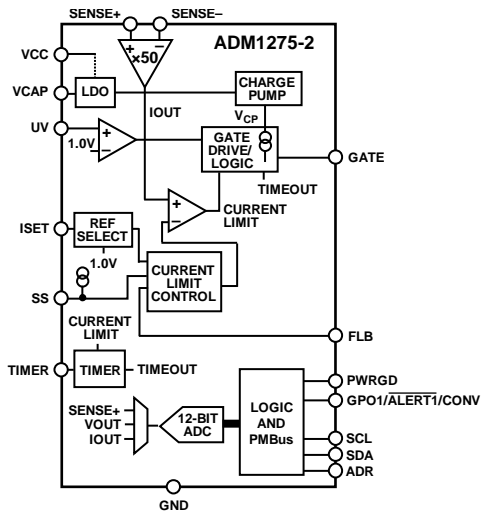

Figure 44. ADM1275-2 Functional Block Diagram

THEORY OF OPERATION

When circuit boards are inserted into a live backplane, discharged supply bypass capacitors draw large transient currents from the backplane power bus as they charge. These transient currents can cause permanent damage to connector pins, as well as dips on the backplane supply that can reset other boards in the system.

The [ADM1275](#) is designed to control the powering on and off of a system in a controlled manner, allowing a board to be removed from, or inserted into, a live backplane by protecting it from excess currents. The [ADM1275](#) can reside on the back-plane or on the removable board.

POWERING THE [ADM1275](#)

A supply voltage from 2.95 V to 20 V is required to power the [ADM1275](#) via the VCC pin. The VCC pin provides the majority of the bias current for the device; the remainder of the current needed to control the gate drive and best regulate the V_{GS} voltage is supplied by the SENSE+ pin.

To ensure correct operation of the [ADM1275](#), the voltage on the VCC pin must be greater than or equal to the voltage on the SENSE+ pin. No sequencing of the VCC and SENSE+ rails is necessary. The SENSE+ pin can be as low as 2 V for normal operation provided that a voltage of at least 2.95 V is connected to the VCC pin. In most applications, both the VCC and SENSE+ pins are connected to the same voltage rail, but they are connected via separate traces to prevent accuracy loss in the sense voltage measurement (see Figure 46).

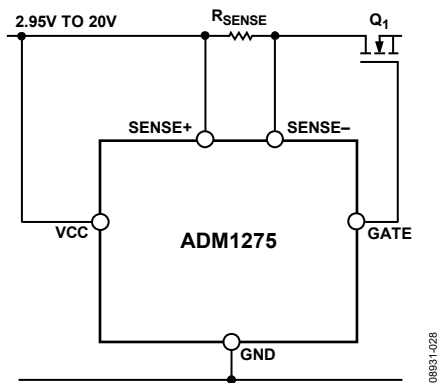

Figure 46. Powering the [ADM1275](#)

To protect the [ADM1275](#) from unnecessary resets due to transient supply glitches, an external resistor and capacitor can be added, as shown in Figure 47. The values of these components should be chosen to provide a time constant that can filter any expected glitches. The resistor should, however, be small enough to keep voltage drops due to quiescent current to a minimum. A supply decoupling capacitor should not be placed on the rail before the FET unless a resistor is used to limit the inrush current.

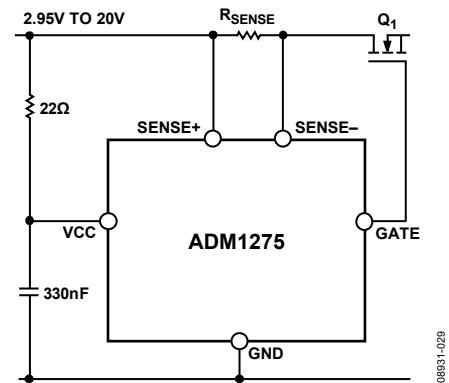

Figure 47. Transient Glitch Protection Using an RC Network

CURRENT SENSE INPUTS

The load current is monitored by measuring the voltage drop across an external sense resistor, R_{SENSE} (see Figure 48). An internal current sense amplifier provides a gain of 50 to the voltage drop detected across R_{SENSE} . The result is compared to an internal reference and used by the hot-swap control logic to detect when an overcurrent condition occurs.

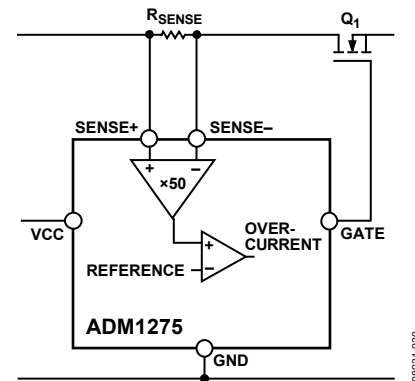

Figure 48. Hot-Swap Current Sense Amplifier

The SENSE inputs may be connected to multiple parallel sense resistors, which can affect the voltage drop detected by the [ADM1275](#). The current flowing through the sense resistors creates an offset, resulting in reduced accuracy.

To achieve better accuracy, averaging resistors sum the current from the nodes of each sense resistor, as shown in Figure 49. The typical value for the averaging resistors is 10 Ω . The value of the averaging resistors is chosen to be much greater than the trace resistance between the sense resistors terminals and the inputs to the [ADM1275](#). This greatly reduces the effects of differences in the trace resistances.

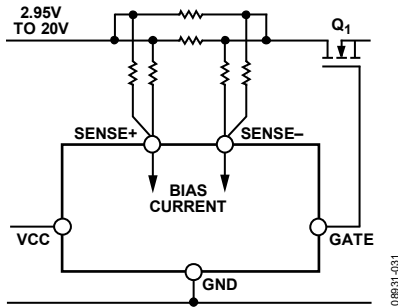

Figure 49. Connection of Multiple Sense Resistors to the SENSE Pins

CURRENT LIMIT REFERENCE

The current limit reference voltage determines the load current level to which the ADM1275 limits the current during an overcurrent event. This reference voltage is compared to the gained-up current sense voltage to determine whether the limit is reached.

An internal current limit reference selector block continuously compares the ISET, soft start, and foldback voltages to determine which voltage is the lowest at any given time; the lowest voltage is used as the current limit reference. This ensures that the programmed current limit, ISET, is used in normal operation, and that the soft start and foldback features reduce the current limit when required during startup and/or fault conditions.

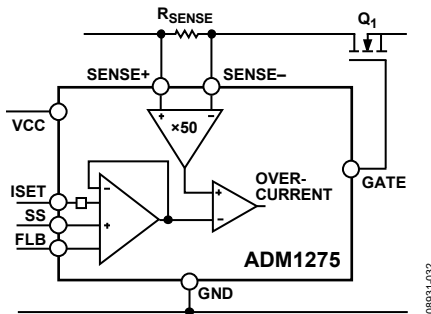

Figure 50. Current Limit Reference Selection

The foldback and soft start voltages vary during different modes of operation and are, therefore, clamped to minimum levels of 200 mV and 100 mV, respectively, to prevent zero current flow due to the current limit being too low. Figure 51 provides an example of how the soft start, foldback, and ISET voltages interact during startup as the ADM1275 is enhancing the FET and charging the load capacitances. Depending on how the soft start and foldback features are configured, the hand-off point can vary to ensure that the FET is operated correctly.

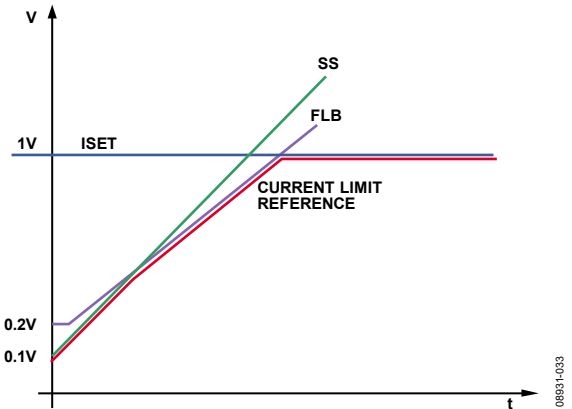

Figure 51. Interaction of Soft Start, Foldback, and ISET Current Limits

SETTING THE CURRENT LIMIT (ISET)

The maximum current limit is partially determined by selecting a sense resistor to match the current sense voltage limit on the controller for the desired load current. However, as currents become larger, the sense resistor requirements become smaller, and resolution can be difficult to achieve when selecting the appropriate sense resistor. The ADM1275 provides an adjustable current sense voltage limit to handle this issue. The device allows the user to program the required current sense voltage limit from 5 mV to 25 mV.

The default value of 20 mV is achieved by connecting the ISET pin directly to the VCAP pin. This configures the device to use an internal 1 V reference, which equates to 20 mV at the sense inputs (see Figure 52).

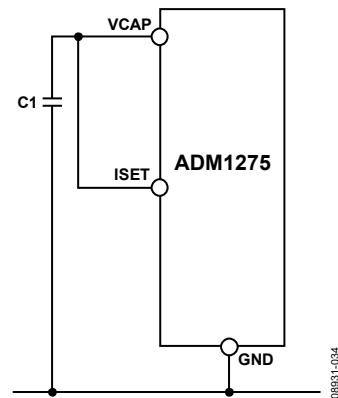

Figure 52. Fixed 20 mV Current Sense Limit

To program the sense voltage from 5 mV to 25 mV, a resistor divider is used to set a reference voltage on the ISET pin (see Figure 53).

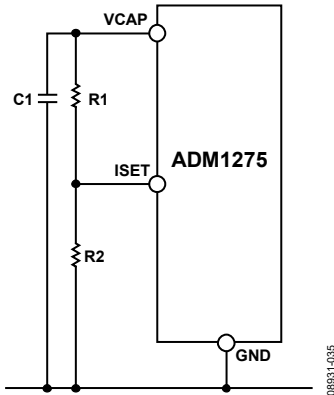

Figure 53. Adjustable 5 mV to 25 mV Current Sense Limit

The VCAP pin has a 2.7 V ($\pm 1.5\%$) internal generated voltage that can be used to set a voltage at the ISET pin. Assuming that V_{ISET} equals the voltage on the ISET pin, the resistor divider should be sized to set the ISET voltage as follows:

$$V_{ISET} = V_{SENSE} \times 50$$

where V_{SENSE} is the current sense voltage limit.

The VCAP rail can also be used as the pull-up supply for setting the I²C address. The VCAP pin should not be used for any other purpose. To guarantee accuracy specifications, care should be taken not to load the VCAP pin by more than 100 μ A.

SOFT START

A capacitor connected to the SS pin determines the inrush current profile. Before the FET is enabled, the output voltage of the current limit reference selector block is clamped at 100 mV. This, in turn, holds the hot-swap sense voltage current limit, $V_{SENSECL}$, at approximately 2 mV. When the FET is requested to turn on, the SS pin is held at ground until the voltage between the SENSE+ and SENSE- pins (V_{SENSE}) reaches the circuit breaker voltage, V_{CB} .

$$V_{CB} = V_{SENSECL} - V_{CBOS}$$

where V_{CBOS} is typically 0.88 mV, making $V_{CB} = 1.12$ mV.

When the load current generates a sense voltage equal to V_{CB} , a 10 μ A current source is enabled, which charges the SS capacitor and results in a linear ramping voltage on the SS pin. The current limit reference also ramps up accordingly, allowing the regulated load current to ramp up while avoiding sudden transients during power-up. The SS capacitor value is given by

$$C_{SS} = \frac{I_{SS} \times t}{V_{ISET}}$$

where:

$I_{SS} = 10 \mu$ A.

$t =$ SS ramp time.

For example, a 10 nF capacitor gives a soft start time of 1 ms.

Note that the SS voltage may intersect with the FLB (foldback) voltage, and the current limit reference may change to follow FLB (see Figure 51). This change has minimal impact on startup because the output voltage rises at a similar rate to the SS voltage.

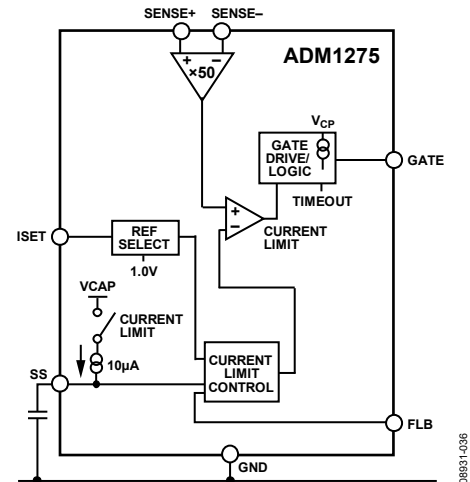

Figure 54. Soft Start

FOLDBACK

Foldback is a method to actively reduce the current limit as the voltage drop across the FET increases. It keeps the power across the FET to a minimum during power-up, overcurrent, or short-circuit events. It also avoids the need to oversize the FET to accommodate worst-case conditions, resulting in board size and cost savings.

The ADM1275 detects the voltage drop across the FET by looking at a resistor-divided version of the output voltage. It is assumed that the supply voltage remains constant and within tolerance. The device therefore relies on the principle that the drain of the FET is at the maximum expected supply voltage, and that the magnitude of the output voltage is relative to that of the V_{DS} of the FET. Using a resistor divider from the output voltage to the FLB pin, a relationship from V_{OUT} , and thus V_{DS} , to V_{FLB} can be derived.

The resistor divider should be designed to output a voltage equal to ISET when V_{OUT} falls below the desired level. This should be well below the working tolerance of the supply rail. As V_{OUT} continues to drop, the current limit reference follows V_{FLB} because it is now the lowest voltage input to the current limit reference selector block. This results in a reduction of the current limit and, therefore, the regulated load current. To prevent complete current flow restriction, a clamp becomes active when the current limit reference reaches 200 mV. The current limit cannot drop below this level.

To suit the SOA characteristics of a particular FET, the required minimum current for this clamp varies from design to design. However, the current limit reference fixes this clamp at 200 mV, which equates to 4 mV at the sense resistor. Therefore, the main ISET voltage can be adjusted to align this clamp to the required percentage current reduction. For example, if ISET equals 0.8 V, the clamp can be set at 25% of the maximum current.

TIMER

The TIMER pin handles several timing functions with an external capacitor, C_{TIMER} . The two comparator thresholds are V_{TIMERL} (0.2 V) and V_{TIMERH} (1 V). There are four timing current sources: a 3 μ A pull-up, a 60 μ A pull-up, a 2 μ A pull-down, and a 100 μ A pull-down.

These current and voltage levels, together with the value of C_{TIMER} chosen by the user, determine the initial timing cycle time, the fault current limit time, and the hot-swap retry duty cycle. The TIMER capacitor value is determined using the following equation:

$$C_{TIMER} = (t_{ON} \times 60 \mu\text{A}) / V_{TIMERH}$$

where t_{ON} is the time that the FET is allowed to spend in regulation at the set current limit. The choice of FET is based on matching this time with the SOA requirements of the FET. Foldback can be used to simplify the selection.

When VCC is connected to the backplane supply, the internal supply of the ADM1275 must be charged up. In a very short time, the internal supply is fully charged up and, because the undervoltage lockout (UVLO) voltage is exceeded at VCC, the device comes out of reset. During this first short reset period, the GATE and TIMER pins are both held low.

The ADM1275 then goes through an initial timing cycle. The TIMER pin is pulled high with 3 μ A. When the TIMER reaches the V_{TIMERH} threshold (1.0 V), the first portion of the initial timing cycle is complete. The 100 μ A current source then pulls down the TIMER pin until it reaches V_{TIMERL} (0.2 V). The initial timing cycle duration is related to C_{TIMER} by the following equation:

$$t_{INITIAL} = \frac{V_{TIMERH} \times C_{TIMER}}{3 \mu\text{A}} + \frac{(V_{TIMERH} - V_{TIMERL}) \times C_{TIMER}}{100 \mu\text{A}}$$

For example, a 100 nF capacitor results in a delay of approximately 34 ms. If the UV and OV inputs indicate that the supply is within the defined window of operation when the initial timing cycle terminates, the device is ready to start a hot-swap operation.

When the voltage across the sense resistor reaches the circuit breaker trip voltage, V_{CB} , the 60 μ A timer pull-up current is activated, and the gate begins to regulate the current at the current limit. This initiates a ramp-up on the TIMER pin. If the sense voltage falls below this circuit breaker trip voltage before the TIMER pin reaches V_{TIMERH} , the 60 μ A pull-up is disabled and the 2 μ A pull-down is enabled.

The circuit breaker trip voltage is not the same as the hot-swap sense voltage current limit. There is a small circuit breaker offset, V_{CBOS} , which means that the timer actually starts a short time before the current reaches the defined current limit.

However, if the overcurrent condition is continuous and the sense voltage remains above the circuit breaker trip voltage, the 60 μ A pull-up remains active and the FET remains in regulation.

This allows the TIMER pin to reach V_{TIMERH} and initiate the GATE shutdown. On the ADM1275-1 and ADM1275-3, the LATCH pin is pulled low immediately.

In latch-off mode, the TIMER pin is switched to the 2 μ A pull-down when it reaches the V_{TIMERH} threshold. The LATCH pin (ADM1275-1 and ADM1275-3) remains low. While the TIMER pin is being pulled down, the hot-swap controller is kept off and cannot be turned back on.

When the voltage on the TIMER pin goes below the V_{TIMERL} threshold, the hot-swap controller can be reenabled by toggling the UV pin or by using the PMBus OPERATION command to toggle the ON bit from on to off and then on again.

HOT-SWAP RETRY DUTY CYCLE

The ADM1275-1 and ADM1275-3 turn off the FET after an overcurrent fault and then use the capacitor on the TIMER pin to provide a delay before automatically retrying the hot-swap operation. To configure the ADM1275-1 and ADM1275-3 for autoretry mode, the LATCH pin is tied to the UV pin or to the ENABLE pin (ADM1275-3 only). Note that a pull-up is required on the LATCH pin.

When an overcurrent fault occurs, the TIMER capacitor is charged with a 60 μ A pull-up current. When the TIMER pin reaches V_{TIMERH} , the GATE pin is pulled down. When the LATCH pin is tied to the UV pin or the ENABLE pin for autoretry mode, the TIMER pin is pulled down with a 2 μ A current sink. When the TIMER pin reaches V_{TIMERL} (0.2 V), it automatically restarts the hot-swap operation.

The duty cycle of this automatic retry cycle is set by the ratio of 2 μ A/60 μ A, which approximates to being on about 4% of the time. The value of the timer capacitor determines the on time of this cycle, which is calculated as follows:

$$t_{ON} = V_{TIMERH} \times (C_{TIMER} / 60 \mu\text{A})$$

$$t_{OFF} = (V_{TIMERH} - V_{TIMERL}) \times (C_{TIMER} / 2 \mu\text{A})$$

A 100 nF TIMER capacitor gives an on time of 1.67 ms and an off time of 40 ms. The device retries indefinitely in this manner and can be disabled manually by holding the UV or ENABLE pin low or by disconnecting the LATCH pin. To prevent thermal stress, an RC network can be used to extend the retry time to any desired level.

FET GATE DRIVE CLAMPS

The charge pump used on the GATE pin is capable of driving the pin to $V_{CC} + (2 \times V_{CC})$, but it is clamped to less than 14 V above the SENSE pins and less than 31 V. These clamps ensure that the maximum V_{GS} rating of the FET is not exceeded.

FAST RESPONSE TO SEVERE OVERCURRENT

The ADM1275 features a separate high bandwidth current sense amplifier that is used to detect a severe overcurrent that is indicative of a short-circuit condition. A fast response time allows the ADM1275 to handle events of this type that could otherwise cause catastrophic damage if not detected and acted on very quickly. The fast response circuit ensures that the ADM1275 can detect an overcurrent event at approximately 200% to 250% of the normal current limit (ISET) and can respond to and control the current within 1 μs, in most cases.

UNDERVOLTAGE AND OVERVOLTAGE

The ADM1275 monitors the supply voltage for undervoltage (UV) and overvoltage (OV) conditions. The UV and OV pins are connected to the input of an internal voltage comparator, and its voltage level is internally compared with a 1 V voltage reference.

Figure 55 illustrates the voltage monitoring input connections. An external resistor network divides the supply voltage for monitoring. An undervoltage event is detected when the voltage connected to the UV pin falls below 1 V, and the gate is shut down using the 10 mA pull-down device. Similarly, when an overvoltage event occurs and the voltage on the OV pin exceeds 1 V, the gate is shut down using the 10 mA pull-down device.

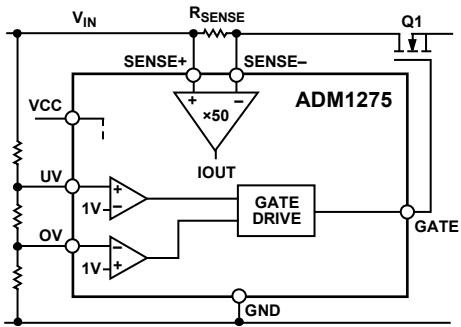

Figure 55. Undervoltage and Overvoltage Supply Monitoring

ENABLE INPUT (ADM1275-3 ONLY)

The ADM1275-3 provides a dedicated ENABLE digital input pin instead of the GPO1/ALERT1/CONV pin on the ADM1275-1 and the ADM1275-2.

The ENABLE pin allows the ADM1275-3 to be kept off using a hardware signal, even when the voltage on the UV pin is above 1.0 V and the voltage on the OV pin is less than 1.0 V. Although the UV pin can be used to provide a digital enable signal, using the ENABLE pin for this purpose means that the ability to monitor for undervoltage conditions is not lost.

In addition to the conditions for the UV and OV pins, the ADM1275-3 ENABLE input pin must be high for the device to begin a power-up sequence.

If an enable function is required on the ADM1275-1 or ADM1275-2, which do not have a dedicated ENABLE pin, a similar function can be achieved using the UV pin directly. Alternatively, if the UV divider function is still required, the configuration shown in Figure 56 can be used.

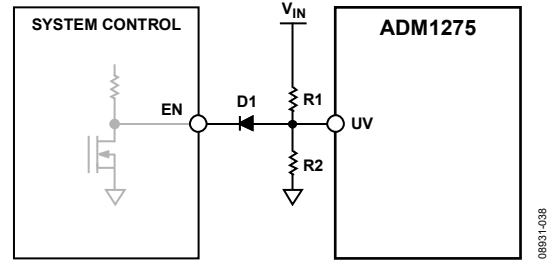

Figure 56. Using the UV Pin as an Enable

Diode D1 prevents the external driver pull-up from affecting the UV threshold. Select Diode D1 using the following criteria:

$$(V_F \times DI) + (V_{OL} \times EN) \ll 1.0 \text{ V} \quad (I_F = V_{IN}/R1)$$

Make sure that the EN sink current does not exceed the specified V_{OL} value. If the open-drain device has no pull-up, the diode is not required.

POWER GOOD

The PWRGD output can be used to indicate whether the output voltage is above a user-defined threshold and can, therefore, be considered good. The PWRGD output is derived using the FLB resistor network, composed of R1 and R2 (see Figure 57).

PWRGD is an open-drain output that pulls low when the voltage at the FLB pin is lower than $1.1 \times V_{ISET}$ (power bad). When the voltage at the FLB pin is above this threshold (indicating that the output voltage is up), the open-drain pull-down is disabled, allowing PWRGD to be pulled high. PWRGD is guaranteed to be in a valid state for $V_{CC} \geq 1 \text{ V}$.

Hysteresis on the FLB pin is provided by a 2 μA internal current source that is switched on when the V_{FLB} input voltage exceeds the input threshold. The current source is disconnected when V_{OUT} drops below the foldback threshold voltage minus the hysteresis voltage. Resistor R3 is internal to the ADM1275. The hysteresis voltage at the FLB pin can be varied by adjusting the parallel combination of Resistor R1 and Resistor R2.

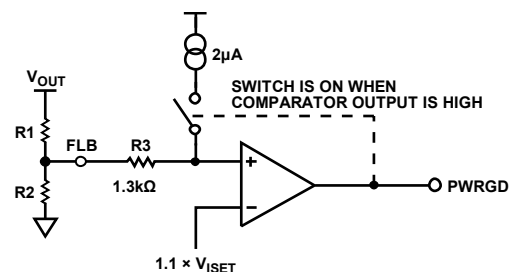

Figure 57. Generation of PWRGD Signal

VOUT MEASUREMENT

The VOUT pin on the ADM1275-1 and ADM1275-3 can be used to provide an alternate voltage for the power monitor to measure. The user can choose to measure the voltage at the SENSE+ pin or the voltage at the VOUT pin, using either the low or high input voltage range.

If the VOUT pin will be used to measure the output voltage after the FET, a 1 k Ω resistor should be inserted in series between the source of the FET and the VOUT pin. This resistor provides some separation between the ADM1275 and the FET source during a fault condition, so that ADM1275 operation is not affected.

FET HEALTH

The ADM1275 provides a method of detecting a shorted pass FET. The FET health status can be used to generate an alert on the GPO1/ALERT1/CONV and GPO2/ALERT2 pins. By default at power-up, an alert is generated on the GPO2/ALERT2 pin of the ADM1275-1 and ADM1275-3 if the FET health status indicates that a bad FET is present. FET health is considered bad if all of the following conditions are true:

- The ADM1275 is holding the FET off, for example, during the initial power-on cycle time.
- $V_{\text{SENSE}} > 2 \text{ mV}$.
- $V_{\text{GATE}} < \sim 1 \text{ V}$, that is, less than the FET gate threshold.

POWER MONITOR

The ADM1275 features an integrated ADC that is used to accurately measure the current sense voltage and either the input or output voltage. Because the ADM1275-1 and ADM1275-3 have a VOUT pin, the power monitor can be configured using the PMBus to measure either the input or the output voltage. The ADM1275-2 does not have a VOUT pin, so only the input voltage at the SENSE+ pin can be measured.

The ADM1275 can report the measured current and either the input or output voltage. The PEAK_IOUT, PEAK_VIN, and PEAK_VOUT commands can be used to read the highest peak current or voltage since the value was last cleared.

An averaging function is provided for voltage and current that allows a number of samples to be averaged by the ADM1275. This function reduces the need for postprocessing of sampled data by the host processor. The number of samples that can be averaged is 2^N , where N is in the range of 0 to 7.

The power monitor current sense amplifier is bipolar and can measure both positive and negative currents. The power monitor amplifier has an input range of $\pm 25 \text{ mV}$.

Two input voltage ranges are available and can be selected using the PMBus interface: 0 V to 6 V (low input range) and 0 V to 20 V (high input range).

The two basic modes of operation for the power monitor are single shot and continuous. In single-shot mode, the power monitor samples the input voltage and current a number of times, depending on the averaging value selected by the user. The ADM1275 returns a single value corresponding to the average voltage and current measured. When configured for continuous mode, the power monitor continuously samples voltage and current, making the most recent sample available to be read.

The single-shot mode can be triggered in a number of ways. The simplest is by selecting the single-shot mode using the PMON_CONFIG command and writing the CONVERT bit using the PMON_CONTROL command. The CONVERT bit can also be written as part of a PMBus group command. Using a group command allows multiple devices to be written to as part of the same I²C bus transaction, with all devices executing the command when the stop condition appears on the bus. In this way, several devices can be triggered to sample at the same time.

When the GPO1/ALERT1/CONV pin is set to the convert (CONV) mode, an external hardware signal can be used to trigger the single-shot sampling of one or more parts at the same time.

PMBus INTERFACE

The I²C bus is a common, simple serial bus used by many devices to communicate. It defines the electrical specifications, the bus timing, the physical layer, and some basic protocol rules.

SMBus is based on I²C and aims to provide a more robust and fault-tolerant bus. Functions such as bus timeout and packet error checking are added to help achieve this robustness, along with more specific definitions of the bus messages used to read and write data to devices on the bus.

PMBus is layered on top of SMBus and, in turn, on I²C. Using the SMBus defined bus messages, PMBus defines a set of standard commands that can be used to control a device that is part of a power chain.

The [ADM1275](#) command set is based upon the PMBus™ Power System Management Protocol Specification, Part I and Part II, Revision 1.1. This version of the standard is intended to provide a common set of commands for communicating with dc-to-dc type devices. However, many of the standard PMBus commands can be mapped directly to the functions of a hot-swap controller.

Part I and Part II of the PMBus standard describe the basic commands and how they can be used in a typical PMBus setup. The following sections describe how the PMBus standard and the [ADM1275](#) specific commands are used.

DEVICE ADDRESSING

The [ADM1275](#) is available in three models: the [ADM1275-1](#), the [ADM1275-2](#), and the [ADM1275-3](#). The PMBus address is 7 bits in size. The upper 5 bits (MSBs) of the address word are fixed and are different for each model, as follows:

- [ADM1275-1](#): Base address is 00100xx (0x10)
- [ADM1275-2](#): Base address is 00110xx (0x18)
- [ADM1275-3](#): Base address is 01000xx (0x20)

The [ADM1275-1](#), [ADM1275-2](#), and [ADM1275-3](#) all have a single ADR pin that is used to select one of four possible addresses for a given model. The ADR pin connection selects the lowest two bits (LSBs) of the 7-bit address word (see Table 8).

Table 8. PMBus Addresses and ADR Pin Connection

| Value of Address LSBs | ADR Pin Connection |
|-----------------------|--------------------------|
| 00 | Connect to GND |
| 01 | 150 kΩ resistor to GND |
| 10 | No connection (floating) |
| 11 | Connect to VCAP |

SMBus PROTOCOL USAGE

All I²C transactions on the [ADM1275](#) are done using SMBus defined bus protocols. The following SMBus protocols are implemented by the [ADM1275](#):

- Send byte
- Receive byte
- Write byte
- Read byte
- Write word
- Read word
- Block read

PACKET ERROR CHECKING

The [ADM1275](#) PMBus interface supports the use of the packet error checking (PEC) byte that is defined in the SMBus standard. The PEC byte is transmitted by the [ADM1275](#) during a read transaction or sent by the bus host to the [ADM1275](#) during a write transaction. The [ADM1275](#) supports the use of PEC with all the SMBus protocols that it implements.

The use of the PEC byte is optional. The bus host can decide whether to use the PEC byte with the [ADM1275](#) on a message-by-message basis. There is no need to enable or disable PEC in the [ADM1275](#).

The PEC byte is used by the bus host or the [ADM1275](#) to detect errors during a bus transaction, depending on whether the transaction is a read or a write. If the host determines that the PEC byte read during a read transaction is incorrect, it can decide to repeat the read if necessary. If the [ADM1275](#) determines that the PEC byte sent during a write transaction is incorrect, it ignores the command (does not execute it) and sets a status flag.

Within a group command, the host can choose to send or not send a PEC byte as part of the message to the [ADM1275](#).

PARTIAL TRANSACTIONS ON I²C BUS

In the event of a specific sequence of events occurring on the I²C bus, it is possible for the I²C interface on the device to go into a state where it fails to ACK the next I²C transaction directed to it. There are two ways that this behavior can be triggered:

- A partial I²C transaction consisting of a start condition, followed by a single SCL clock pulse and stop condition.
- If the I²C bus master does not follow the 300 ns SDA data hold time when signaling the ACK/NACK bit at the end of a transaction. The device sees this as a single SCL clock partial transaction.

In the event that the device NACKs a transaction, then the I²C interface on the device can be reset by sending a series of up to 16 SCL clock pulses, or performing a dummy transaction to another I²C address on the bus.

SMBus MESSAGE FORMATS

Figure 58 to Figure 65 show all the SMBus protocols supported by the ADM1275, along with the PEC variant. In these figures, unshaded cells indicate that the bus host is actively driving the bus; shaded cells indicate that the ADM1275 is driving the bus.

Figure 58 to Figure 65 use the following abbreviations:

S = start condition

Sr = repeated start condition

P = stop condition

R = read bit

\bar{W} = write bit

\bar{A} = acknowledge bit (0)

A = acknowledge bit (1)

“A” represents the ACK (acknowledge) bit. The ACK bit is typically active low (Logic 0) if the transmitted byte is successfully received by a device. However, when the receiving device is the bus master, the acknowledge bit for the last byte read is a Logic 1, indicated by \bar{A} .

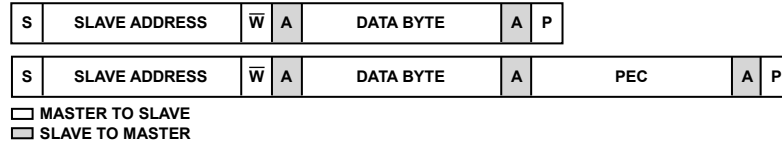

Figure 58. Send Byte and Send Byte with PEC

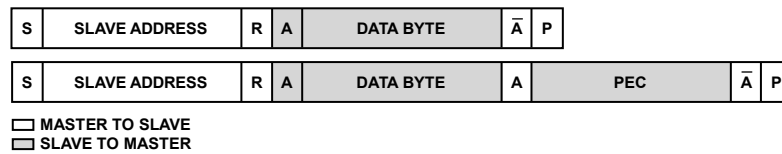

Figure 59. Receive Byte and Receive Byte with PEC

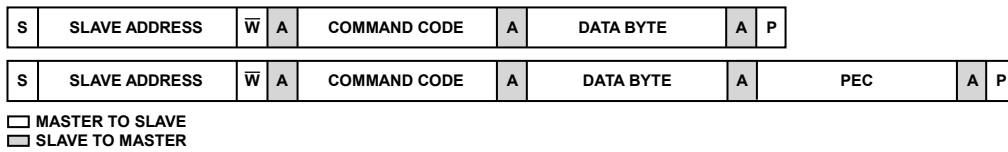

Figure 60. Write Byte and Write Byte with PEC

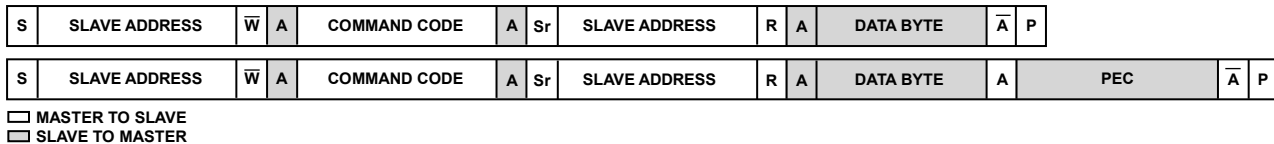

Figure 61. Read Byte and Read Byte with PEC

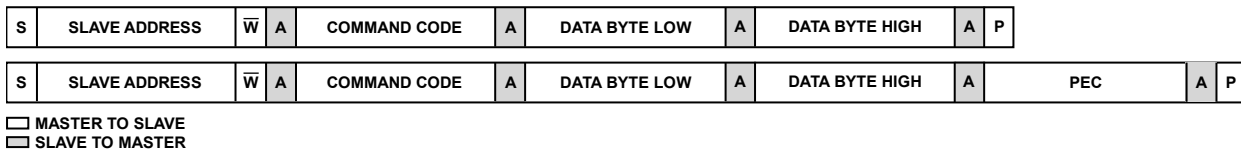

Figure 62. Write Word and Write Word with PEC

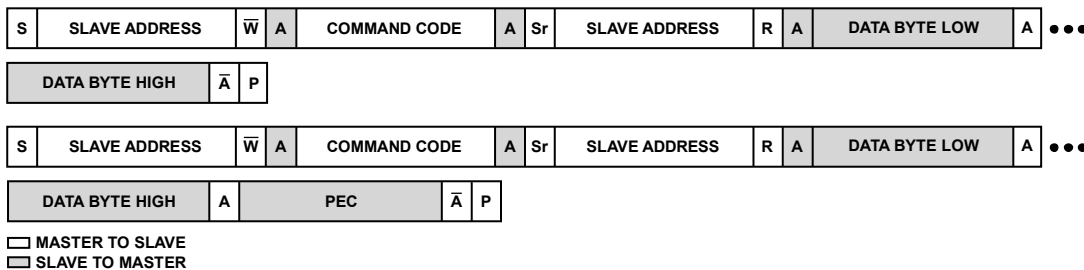

Figure 63. Read Word and Read Word with PEC

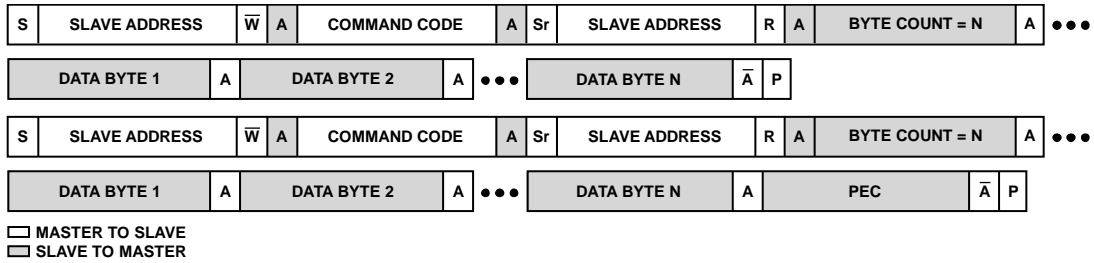

Figure 64. Block Read and Block Read with PEC

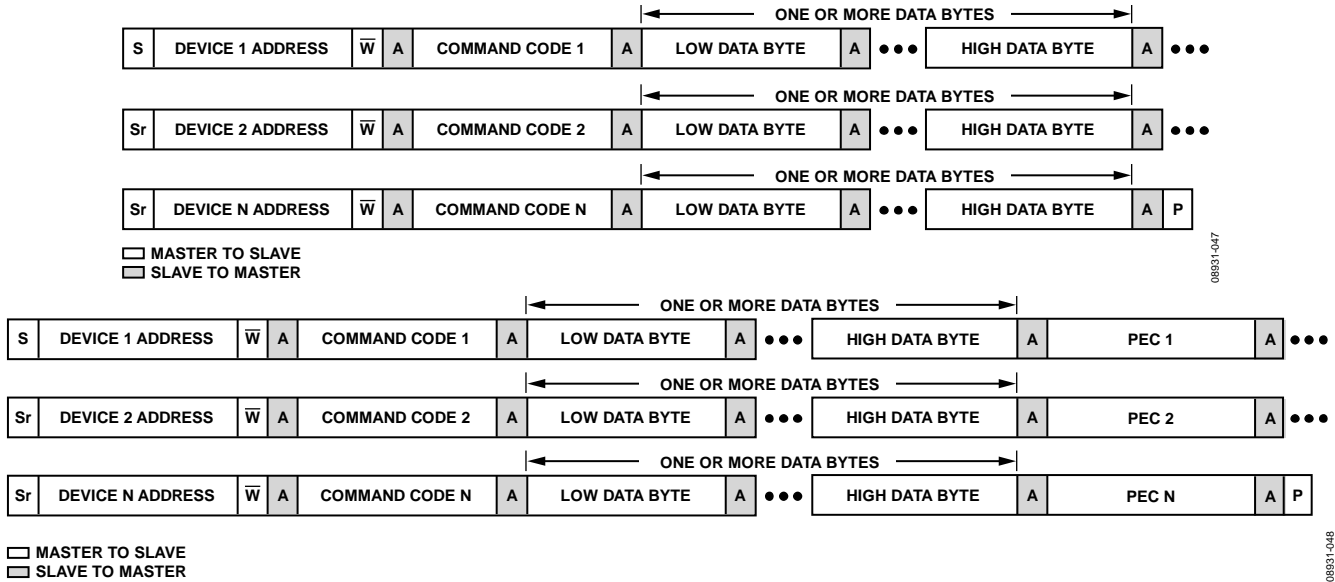

Figure 65. Group Command and Group Command with PEC

GROUP COMMANDS

The PMBus standard defines what are known as group commands. Group commands are single bus transactions that send commands or data to more than one device at the same time. Each device is addressed separately, using its own address; there is no special group command address. A group command transaction can contain only write commands that send data to a device. It is not possible to use a group command to read data from devices.

From an I²C protocol point of view, a normal write command consists of the following:

- I²C start condition
- Slave address bits and a write bit (followed by ACK from the slave device)
- One or more data bytes (each of which is followed by ACK from the slave device)
- I²C stop condition to end the transaction

A group command differs from a nongroup command in that after the data is written to one slave device, a repeated start condition is put on the bus followed by the address of the next slave device and data. This continues until all the devices have been written to, at which point the stop condition is put on the bus by the master device.

The format of a group command and a group command with PEC is shown in Figure 65.

Each device that is written to as part of the group command does not immediately execute the command written. The device must wait until the stop condition appears on the bus. At that point, all devices execute their commands at the same time.

Using a group command, it is possible, for example, to turn multiple PMBus devices on or off at the same time. In the case of the ADM1275, it is also possible to issue a power monitor command that initiates a conversion, causing multiple ADM1275 devices to sample together at the same time. This is analogous to connecting the GPO1/ALERT1/CONV pins together and configuring the pin in the convert (CONV) mode to drive the power monitor sampling.

HOT-SWAP CONTROL COMMANDS

OPERATION Command

The GATE pin that drives the FET is controlled by a dedicated hot-swap state machine. The UV and OV input pins, along with the TIMER and SS pins and the current sense, all feed into the state machine and control when and how strongly the gate is turned off.

It is also possible to control the hot-swap GATE output using commands over the PMBus interface. The OPERATION command can be used to request the hot-swap output to turn on. However, if the UV pin indicates that the input supply is less than required, the hot-swap output is not turned on, even if the OPERATION command indicates that the output should be enabled.

If the OPERATION command is used to disable the hot-swap output, the GATE pin is held low, even if all hot-swap state machine control inputs indicate that it can be enabled.

The default state of the OPERATION command ON bit is 1, so the hot-swap output is always enabled when the ADM1275 comes out of UVLO. If the ON bit is never changed, the UV input (or the ENABLE input on the ADM1275-3) is the hot-swap master on/off control signal.

By default at power-up, the OPERATION command is disabled and must be enabled using the DEVICE_CONFIG command. This prevents inadvertent shutdowns of the hot-swap controller by software.

If the ON bit is set to 0 while the UV signal is high, the hot-swap output is turned off. If the UV signal is low or if the OV signal is high, the hot-swap output will already be off and the status of the ON bit has no effect.

If the ON bit is set to 1, the hot-swap output is requested to turn on. If the UV signal is low or if the OV signal is high, setting the ON bit to 1 has no effect, and the hot-swap output remains off.

It is possible to determine at any time whether the hot-swap output is enabled using the STATUS_BYTE or the STATUS_WORD command (see the Status Commands section).

The OPERATION command can also be used to clear any latched faults in the status registers. To clear latched faults, set the ON bit to 0 and then reset it to 1.

DEVICE_CONFIG Command

The DEVICE_CONFIG command is used to configure certain settings within the ADM1275, for example, to enable or disable foldback in the hot-swap controller or to modify the duration of the severe overcurrent glitch filter. This command is also used to configure the polarity of the second IOUT current warnings.

At power-up, the OPERATION command is disabled and the ADM1275 responds with a NACK if the OPERATION command is received. To allow use of the OPERATION command, the OPERATION_CMD_EN bit must be set using the DEVICE_CONFIG command.

POWER_CYCLE Command

The POWER_CYCLE command can be used to request that the ADM1275 be turned off for ~4 seconds and then back on. This command can be useful if the processor that controls the ADM1275 is also powered off when the ADM1275 is turned off. This command allows the processor to request that the ADM1275 turn off and back on again as part of a single command.

ADM1275 INFORMATION COMMANDS

CAPABILITY Command

The CAPABILITY command can be used by host processors to determine the I²C bus features supported by the ADM1275. The features reported are the maximum bus speed and whether the device supports the packet error checking (PEC) byte and the SMBAlert reporting function.

PMBUS_REVISION Command

The PMBUS_REVISION command reports the version of Part I and Part II of the PMBus standard.

MFR_ID, MFR_MODEL, and MFR_REVISION Commands

The MFR_ID, MFR_MODEL, and MFR_REVISION commands return ASCII strings that can be used to facilitate detection and identification of the ADM1275 on the bus.

These commands are read using the SMBus block read message type. This message type requires that the ADM1275 return a byte count corresponding to the length of the string data that is to be read back.

STATUS COMMANDS

The ADM1275 provides a number of status bits that are used to report faults and warnings from the hot-swap controller and the power monitor. These status bits are located in six different registers that are arranged in a hierarchy. The STATUS_BYTE and STATUS_WORD commands provide 8 bits and 16 bits of high level information, respectively. The STATUS_BYTE and STATUS_WORD commands contain the most important status bits, as well as pointer bits that indicate whether any of the four other status registers need to be read for more detailed status information.

In the ADM1275, a particular distinction is made between faults and warnings. A fault is always generated by the hot-swap controller and is defined by hardware component values. Three events can generate a fault:

- Overcurrent condition that causes the hot-swap timer to time out
- Overvoltage condition on the OV pin
- Undervoltage condition on the UV pin

When a fault occurs, the hot-swap controller always takes some action, usually to turn off the GATE pin, which is driving the FET. A fault can also generate an SMBAlert on one or both of the GPOx/ALERTx pins.

All warnings in the [ADM1275](#) are generated by the power monitor sampling voltage and current and then comparing these measurements to the threshold values set by the various limit commands. A warning has no effect on the hot-swap controller, but it may generate an SMBAlert on one or both of the GPOx/ALERTx output pins.

When a status bit is set, it always means that the status condition—fault or warning—is active or was active at some point in the past. When a fault or warning bit is set, it is latched until it is explicitly cleared using either the OPERATION or the CLEAR_FAULTS command. Some other status bits are live, that is, they always reflect a status condition and are never latched.

STATUS_BYTE and STATUS_WORD Commands

The STATUS_BYTE and STATUS_WORD commands can be used to obtain a snapshot of the overall part status. These commands indicate whether it is necessary to read more detailed information using the other status commands.

The low byte of the word returned by the STATUS_WORD command is the same byte returned by the STATUS_BYTE command. The high byte of the word returned by the STATUS_WORD command provides a number of bits that can be used to determine which of the other status commands needs to be issued to obtain all active status bits.

STATUS_INPUT Command

The STATUS_INPUT command returns a number of bits relating to voltage faults and warnings on the input supply.

STATUS_VOUT Command

The STATUS_VOUT command returns a number of bits relating to voltage faults and warnings on the output supply. This command is not available on the [ADM1275-2](#).

STATUS_IOUT Command

The STATUS_IOUT command returns a number of bits relating to current faults and warnings on the output supply.

STATUS_MFR_SPECIFIC Command

The STATUS_MFR_SPECIFIC command is a standard PMBus command, but the contents of the byte returned is specific to the [ADM1275](#).

CLEAR_FAULTS Command

The CLEAR_FAULTS command is used to clear fault and warnings bits when they are set. Fault and warnings bits are latched when they are set. In this way, a host can read the bits any time after the fault or warning condition occurs and determine which problem actually occurred.

If the CLEAR_FAULTS command is issued and the fault or warning condition is no longer active, the status bit is cleared. If the condition is still active—for example, if an input voltage is below the undervoltage threshold of the UV pin—the CLEAR_FAULTS command attempts to clear the status bit, but that status bit is immediately set again.

GPO AND ALERT PIN SETUP COMMANDS

Two multipurpose pins are provided on the [ADM1275-1](#): GPO1/ALERT1/CONV and GPO2/ALERT2. One multi-purpose pin is provided on the [ADM1275-2](#) (GPO1/ALERT1/CONV), and on the [ADM1275-3](#) (GPO2/ALERT2).

The GPO1/ALERT1/CONV and GPO2/ALERT2 pins have two output modes of operation. These pins can be configured independently over the PMBus as general-purpose digital outputs. They can both be configured to generate an SMBAlert when one or more fault/warning status bits become active in the PMBus status registers. For an example of how to configure these pins to generate an SMBAlert and how to respond and clear the condition, see the Example Use of SMBUS Alert Response Address section.

The GPO1/ALERT1/CONV pin can also be configured as an input (CONV) to drive the power monitor in single-shot run mode and to control when a power monitor ADC sampling cycle begins. This function can be used to synchronize sampling across multiple [ADM1275](#) devices, if required.

ALERT1_CONFIG and ALERT2_CONFIG Commands

Using combinations of bit masks, the ALERT1_CONFIG and ALERT2_CONFIG commands can be used to select the status bits that, when set, generate an SMBAlert signal to a processor. They can also be used to set a GPO mode on the pin, so that it is under software control. If this mode is set, the SMBAlert masking bits are ignored.

On the [ADM1275-1](#), one of the inputs can also be configured as a hardware-based convert control signal. If this mode is set, the GPO and SMBAlert masking bits are ignored.

POWER MONITOR COMMANDS

The [ADM1275](#) provides a high accuracy, 12-bit current and voltage power monitor. The power monitor can be configured in a number of different modes of operation and can run in either continuous mode or single-shot mode with a number of different sample averaging options.

PMON_CONFIG Command

The power monitor can run in a number of different modes with different input voltage range settings. The PMON_CONFIG command is used to set up the power monitor.

The settings that can be configured are as follows:

- Single-shot or continuous sampling
- VIN or VOUT sampling (no VOUT sampling for the [ADM1275-2](#))
- Voltage input range
- Current and voltage sample averaging

Modifying the power monitor settings while the power monitor is sampling is not supported. The power monitor must be stopped before any of these settings are changed to ensure correct operation and avoid any potential spurious data and status alerts being generated.

PMON_CONTROL Command

Power monitor sampling can be initiated via software or via hardware, as follows:

- PMON_CONTROL command. This command can be used with single-shot or continuous mode.
- GPO1/ALERT1/CONV pin. If this pin is configured for convert mode, an external hardware signal can be used to take this pin high, triggering the single-shot sampling of one or more parts together.

READ_VIN, READ_VOUT, and READ_IOUT Commands

The ADM1275 power monitor measures the voltage developed across the sense resistor to provide a current measurement. On the ADM1275-1 and ADM1275-3, the user can choose to measure either the input voltage from the SENSE+ pin or the output voltage present on the VOUT pin. The ADM1275-2 can measure only the input voltage from the SENSE+ pin.

PEAK_IOUT, PEAK_VIN, and PEAK_VOUT Commands

In addition to the standard PMBus commands for reading voltage and current, the ADM1275 provides commands that can report the maximum peak voltage or current sample since the peak value was last cleared.

The peak values are updated only after the power monitor has sampled and averaged the current and voltage measurements. Individual peak values are cleared by writing a 0 value with the corresponding command.

WARNING LIMIT SETUP COMMANDS

The ADM1275 power monitor can monitor a number of different warning conditions simultaneously and report any current or voltage values that exceed the user-defined thresholds using the status commands.

All comparisons performed by the power monitor require the measured voltage or current value to be strictly greater or less than the threshold value.

At power-up, all threshold limits are set to either minimum scale (for undervoltage or undercurrent conditions) or to maximum scale (for overvoltage or overcurrent conditions). This effectively disables the generation of any status warnings by default; warning bits are not set in the status registers until the user explicitly sets the threshold values.

VIN_OV_WARN_LIMIT and VIN_UV_WARN_LIMIT Commands

The VIN_OV_WARN_LIMIT and VIN_UV_WARN_LIMIT commands are used to set the OV and UV thresholds on the input voltage, as measured at the SENSE+ pin.

VOUT_OV_WARN_LIMIT and VOUT_UV_WARN_LIMIT Commands

The VOUT_OV_WARN_LIMIT and VOUT_UV_WARN_LIMIT commands are used to set the OV and UV thresholds

on the output voltage, as measured at the VOUT pin on the ADM1275-1 and ADM1275-3.

IOUT_OC_WARN_LIMIT Command

The IOUT_OC_WARN_LIMIT command is used to set the OC threshold for the current flowing through the sense resistor.

IOUT_WARN2_LIMIT Command

The IOUT_WARN2_LIMIT command provides a second current warning threshold that can be programmed. The polarity of this warning can be set to overcurrent or undercurrent using the DEVICE_CONFIG command.

PMBus DIRECT FORMAT CONVERSION

The ADM1275 uses the PMBus direct format to represent real-world quantities such as voltage and current values. A direct format number takes the form of a 2-byte, twos complement, binary integer value.

It is possible to convert between direct format value and real-world quantities using the following equations. Equation 1 converts from real-world quantities to PMBus direct values, and Equation 2 converts PMBus direct format values to real-world values.

$$Y = (mX + b) \times 10^R \quad (1)$$

$$X = 1/m \times (Y \times 10^{-R} - b) \quad (2)$$

where:

Y is the value in PMBus direct format.

X is the real-world value.

m is the slope coefficient, a 2-byte, twos complement integer.

b is the offset, a 2-byte, twos complement integer.

R is a scaling exponent, a 1-byte, twos complement integer.

The same equations are used for voltage and current conversions, the only difference being the values of the m, b, and R coefficients that are used.

Table 9 lists all the coefficients required for the ADM1275. The current coefficients shown are dependent on the value of the external sense resistor used in a given application. This means that an additional calculation must be performed to take the sense resistor value into account to obtain the coefficients for a specific sense resistor value.

The sense resistor value used in the calculations to obtain the coefficients is expressed in milliohms. The m coefficients are defined as 2-byte twos complement numbers in the PMBus standard, therefore the maximum positive value that can be represented is 32767. If the m value is greater than that, and is to be stored in PMBus standard form, then the m coefficients should be divided by 10, and the R coefficient increased by a value of 1. For example, if on the 20 V range, a 10 milliohm sense resistor is used, the m coefficient is 6043, and the R coefficient is -1.

Table 9. PMBus Conversion to Real-World Coefficients

| Coefficient | Current (A) | Voltage (V) | |
|-------------|------------------------|------------------|-------------------|
| | | 0 V to 6 V Range | 0 V to 20 V Range |
| m | $807 \times R_{SENSE}$ | 6720 | 19,199 |
| b | 20,475 | 0 | 0 |
| R | -1 | -1 | -2 |

Example 1

IOUT_OC_WARN_LIMIT requires a current-limit value expressed in direct format.

If the required current limit is 10 A, and the sense resistor is 2 mΩ, then the first step is to determine the voltage coefficient. This is simply $m = 807 \times 2$, giving 1614.

Using Equation 1 and expressing X, in units of Amps

$$Y = ((1614 \times 10) + 20,475) \times 10^{-1}$$

$$Y = 3661.5 = 3662 \text{ (rounded up to integer form)}$$

Writing a value of 3662 with the IOUT_OC_WARN_LIMIT command sets an overcurrent warning at 10 A.

Example 2

The READ_IOUT command returns a direct format value of 3339 representing the current flowing through a sense resistor of 1 mΩ.

To convert this value to the current flowing, use Equation 2, with $m = 807 \times 1$.

$$X = 1/807 \times (3339 \times 10^1 - 20,475)$$

$$X = 16.00 \text{ A}$$

This means that when READ_IOUT returns a value of 3339, 16.00 A is flowing in the sense resistor.

VOLTAGE AND CURRENT CONVERSION USING LSB VALUES

The direct format voltage and current values returned by the READ_VIN, READ_VOUT, READ_IOUT commands, and the corresponding peak versions, are actually the data output directly by the ADM1275 ADC. As the voltages and currents are really a 12-bit ADC output code, they can also be converted to real-world values with knowledge of the size of the LSB on the ADC.

The m, b, R coefficients defined for the PMBus conversion are required to be whole integers by the standard, and have therefore been rounded-off slightly. Using this alternative method, with the exact LSB values, can provide slightly more accurate numerical conversions.

To convert an ADC code to current in amperes, the following formulas can be used:

$$V_{SENSE} = LSB_{25mV} \times (I_{ADC} - 2048)$$

$$I_{OUT} = V_{SENSE} / (R_{SENSE} \times 0.001)$$

where:

$$V_{SENSE} = (V_{SENSE+}) - (V_{SENSE-}).$$

$$LSB_{25mV} = 12.4 \mu\text{V}.$$

I_{ADC} is the 12-bit ADC code.

I_{OUT} is the measured current value in amperes.

R_{SENSE} is the value of the sense resistor in milliohms.

To convert an ADC code to a voltage, the following formula can be used:

$$V_M = LSB_{xV} \times (V_{ADC} + 0.5)$$

where:

V_M is the measured value in volts.

V_{ADC} is the 12-bit ADC code.

LSB_{xV} values are based on the voltage range (see Table 10).

Table 10. Voltage Ranges and LSB Values

| Voltage Range, LSB_{xV} | LSB Magnitude |
|---------------------------|---------------|
| 0 V to 6 V | 1.488 mV |
| 0 V to 20 V | 5.208 mV |

To convert a current in amperes to a 12-bit value, the following formula can be used (round the result to the nearest integer):

$$V_{SENSE} = I_A \times R_{SENSE} \times 0.001$$

$$I_{CODE} = 2048 + (V_{SENSE} / LSB_{25mV})$$

where:

$$V_{SENSE} = (V_{SENSE+}) - (V_{SENSE-}).$$

I_A is the current value in amperes.

R_{SENSE} is the value of the sense resistor in milliohms.

I_{CODE} is the 12-bit ADC code.

$$LSB_{25mV} = 12.4 \mu\text{V}.$$

To convert a voltage to a 12-bit value, the following formula can be used (round the result to the nearest integer):

$$V_{CODE} = (V_A / LSB_{xV}) - 0.5$$

where:

V_{CODE} is the 12-bit ADC code.

V_A is the voltage value in volts.

LSB_{xV} values are based on the voltage range (see Table 10).

ADM1275 ALERT PIN BEHAVIOR

The [ADM1275](#) provides a very flexible alert system, whereby one or more fault/warning conditions can be indicated to an external device.

FAULTS AND WARNINGS

A PMBus fault on the [ADM1275](#) is always generated due to an analog event and causes a change in state in the hot-swap output, turning it off. The three defined fault sources are as follows:

- Undervoltage (UV) event detected on the UV pin
- Overvoltage (OV) event detected on the OV pin
- Overcurrent (OC) event that causes a hot-swap timeout

Faults are continuously monitored, and, as long as power is applied to the device, they cannot be disabled. When a fault occurs, a corresponding status bit is set in one or more STATUS_XXX registers.

A value of 1 in a status register bit field always indicates a fault or warning condition. Fault and warning bits in the status registers are latched when set to 1. To clear a latched bit to 0—provided that the fault condition is no longer active—use the CLEAR_FAULTS command or use the OPERATION command to turn the hot-swap output off and then on again.

A warning is less severe than a fault and never causes a change in the state of the hot-swap controller. The eight sources of a warning are defined as follows:

- CML: a communications error occurred on the I²C bus
- HS timer was active (HSTA): the current regulation was active, but does not necessarily shut the system down
- IOUT OC warning from the ADC
- IOUT Warning 2 from the ADC
- VIN UV warning from the ADC
- VIN OV warning from the ADC
- VOUT UV warning from the ADC ([ADM1275-1](#) and [ADM1275-3](#) only)
- VOUT OV warning from the ADC ([ADM1275-1](#) and [ADM1275-3](#) only)

GENERATING AN ALERT

A host device can periodically poll the [ADM1275](#) using the status commands to determine whether a fault/warning is active. However, this polling is very inefficient in terms of software and processor resources. The [ADM1275](#) has GPOx/ALERTx output pins that can be used to generate interrupts to a host processor.

- [ADM1275-1](#): GPO1/ALERT1/CONV and GPO2/ALERT2
- [ADM1275-2](#): GPO1/ALERT1/CONV
- [ADM1275-3](#): GPO2/ALERT2

By default at power-up, the open-drain GPOx/ALERTx outputs are high impedance, so the pins can be pulled high through resistors. No faults or warnings are enabled on the GPO1/ALERT1/CONV pin at power-up; the user must explicitly enable the faults or warnings to be monitored. The FET health bad warning is active by default on the GPO2/ALERT2 pin at power-up.

Any one or more of the faults and warnings listed in the Faults and Warnings section can be enabled and cause an alert, making the corresponding GPOx/ALERTx pin active. By default, the active state of a GPOx/ALERTx pin is low.

For example, to use GPO1/ALERT1/CONV to monitor the VOUT UV warning from the ADC, the followings steps must be performed:

1. Set a threshold level with the VOUT_UV_WARN_LIMIT command.
2. Start the power monitor sampling on VOUT.

If a VOUT sample is taken that is below the configured VOUT UV value, the GPO1/ALERT1/CONV pin is taken low, signaling an interrupt to a processor.

HANDLING/CLEARING AN ALERT

When faults/warnings are configured on the GPOx/ALERTx pins, the pins become active to signal an interrupt to the processor. (These pins are active low, unless inversion is enabled.) The GPOx/ALERTx signal functions as an SMBAlert.

Note that the GPOx/ALERTx pins can become active independently of each other, but they are always made inactive together.

A processor can respond to the interrupt in one of two basic ways:

- If there is only one device on the bus, the processor can simply read the status bytes and issue a CLEAR_FAULTS command to clear all the status bits, which causes the deassertion of the GPOx/ALERTx line. If there is a persistent fault—for example, an undervoltage on the input—the status bits remain set after the CLEAR_FAULTS command is executed because the fault has not been removed. However, the GPOx/ALERTx line is not pulled low unless a new fault/warning becomes active. If the cause of the SMBAlert is a power monitor generated warning and the power monitor is running continuously, the next sample generates a new SMBAlert after the CLEAR_FAULTS command is issued.
- If there are several devices on the bus, the processor can issue an SMBus alert response address command to find out which device asserted the SMBAlert line. The processor can read the status bytes from that device and issue a CLEAR_FAULTS command.

SMBus ALERT RESPONSE ADDRESS

The SMBus alert response address (ARA) is a special address that can be used by the bus host to locate any devices that need to talk to it. A host typically uses a hardware interrupt pin to monitor the SMBus ALERT pins of a number of devices. When the host interrupt occurs, the host issues a message on the bus using the SMBus receive byte or receive byte with PEC protocol.

The special address used by the host is 0x0C. Any devices that have an SMBAlert signal return their own 7-bit address as the seven MSBs of the data byte. The LSB value is not used and can be either 1 or 0. The host reads the device address from the received data byte and proceeds to handle the alert condition.

More than one device may have an active SMBAlert signal and attempt to communicate with the host. In this case, the device with the lowest address dominates the bus and succeeds in transmitting its address to the host. The device that succeeds disables its SMBus alert signal. If the host sees that the SMBus alert signal is still low, it continues to read addresses until all devices that need to talk to it have successfully transmitted their addresses.

EXAMPLE USE OF SMBus ALERT RESPONSE ADDRESS

The full sequence of steps that occurs when an SMBAlert is generated and cleared is as follows:

1. A fault or warning is enabled using the ALERT1_CONFIG command, and the corresponding status bit for the fault or warning goes from 0 to 1, indicating that the fault/warning has just become active.
2. The GPOx/ALERTx pin becomes active (low) to signal that an SMBAlert is active.
3. The host processor issues an SMBus alert response address to determine which device has an active alert.
4. If there are no other active alerts from devices with lower I²C addresses, this device makes the GPOx/ALERTx pin inactive (high) during the NACK bit period after it sends its address to the host processor.
5. If the GPOx/ALERTx pin stays low, the host processor must continue to issue SMBus alert response address commands to devices to find out the addresses of all devices whose status it must check.
6. The ADM1275 continues to operate with the GPOx/ALERTx pin inactive and the contents of the status bytes unchanged until the host reads the status bytes and clears them, or until a new fault occurs. That is, if a status bit for a fault/warning that is enabled on the GPOx/ALERTx pin and that was not already active (equal to 1) goes from 0 to 1, a new alert is generated, causing the GPOx/ALERTx pin to become active again.

PMBus COMMAND REFERENCE

Register addresses are in hexadecimal format.

Table 11. PMBus Command Summary

| Command Code | Command Name | SMBus Transaction Type | Number of Data Bytes | Default Value at Reset |
|--------------|---------------------|------------------------|---------------------------|---|
| 0x01 | OPERATION | Read/write byte | 1 | 0x80 |
| 0x03 | CLEAR_FAULTS | Send byte | 0 | Not applicable |
| 0x19 | CAPABILITY | Read byte | 1 | 0xB0 |
| 0x42 | VOUT_OV_WARN_LIMIT | Read/write word | 2 | 0x0FFF |
| 0x43 | VOUT_UV_WARN_LIMIT | Read/write word | 2 | 0x0000 |
| 0x4A | IOUT_OC_WARN_LIMIT | Read/write word | 2 | 0x0FFF |
| 0x57 | VIN_OV_WARN_LIMIT | Read/write word | 2 | 0x0FFF |
| 0x58 | VIN_UV_WARN_LIMIT | Read/write word | 2 | 0x0000 |
| 0x78 | STATUS_BYTE | Read byte | 1 | 0x00 |
| 0x79 | STATUS_WORD | Read word | 2 | 0x0000 |
| 0x7A | STATUS_VOUT | Read byte | 1 | 0x00 |
| 0x7B | STATUS_IOUT | Read byte | 1 | 0x00 |
| 0x7C | STATUS_INPUT | Read byte | 1 | 0x00 |
| 0x80 | STATUS_MFR_SPECIFIC | Read byte | 1 | 0x00 |
| 0x88 | READ_VIN | Read word | 2 | 0x0000 |
| 0x8B | READ_VOUT | Read word | 2 | 0x0000 |
| 0x8C | READ_IOUT | Read word | 2 | 0x0000 |
| 0x98 | PMBUS_REVISION | Read byte | 1 | 0x11 |
| 0x99 | MFR_ID | Block read | 1 (byte count) + 3 (data) | 0x03 + ASCII "ADI" |
| 0x9A | MFR_MODEL | Block read | 1 (byte count) + 9 (data) | 0x09 + ASCII "ADM1275- x" ¹ |
| 0x9B | MFR_REVISION | Block read | 1 (byte count) + 1 (data) | 0x01 + ASCII "1" |
| 0xD0 | PEAK_IOUT | Read/write word | 2 | 0x0000 |
| 0xD1 | PEAK_VIN | Read/write word | 2 | 0x0000 |
| 0xD2 | PEAK_VOUT | Read/write word | 2 | 0x0000 |
| 0xD3 | PMON_CONTROL | Read/write byte | 1 | 0x00 |
| 0xD4 | PMON_CONFIG | Read/write byte | 1 | 0x2C |
| 0xD5 | ALERT1_CONFIG | Read/write word | 2 | 0x0000 |
| 0xD6 | ALERT2_CONFIG | Read/write word | 2 | 0x8000 |
| 0xD7 | IOUT_WARN2_LIMIT | Read/write word | 2 | 0x0000 |
| 0xD8 | DEVICE_CONFIG | Read/write byte | 1 | 0x00 |
| 0xD9 | POWER_CYCLE | Send byte | 0 | Not applicable |

¹ The character "x" in the string is 1, 2, or 3, depending on the model of the ADM1275 that is being queried (ADM1275-1, ADM1275-2, or ADM1275-3).

OPERATION

Code: 0x01, read/write byte. Value after reset: 0x80.

Table 12. Bit Descriptions for OPERATION Command

| Bits | Bit Name | Settings | Description |
|-------|----------|----------|--------------------------------------|
| 7 | ON | 0 | Hot-swap output is disabled. |
| | | 1 | Default. Hot-swap output is enabled. |
| [6:0] | Reserved | 0000000 | Always reads as 0000000. |

CLEAR_FAULTS

Code: 0x03, send byte, no data.

CAPABILITY

Code: 0x19, read byte. Value after reset: 0xB0.

Table 13. Bit Descriptions for CAPABILITY Command

| Bits | Bit Name | Settings | Description |
|-------|-----------------------|----------|---|
| 7 | Packet error checking | 1 | Always reads as 1. Packet error checking (PEC) is supported. |
| [6:5] | Maximum bus speed | 01 | Always reads as 01. Maximum supported bus speed is 400 kHz. |
| 4 | SMBALERT# | 1 | Always reads as 1. Device supports SMBAlert and alert response address (ARA). |
| [3:0] | Reserved | 0000 | Always reads as 0000. |

VOUT_OV_WARN_LIMIT

Code: 0x42, read/write word. Value after reset: 0x0FFF.

This command is supported on the [ADM1275-1](#) and the [ADM1275-3](#). The [ADM1275-2](#) does not have a VOUT pin.

Table 14. Bit Descriptions for VOUT_OV_WARN_LIMIT Command

| Bits | Bit Name | Settings | Description |
|---------|--------------------|----------|---|
| [15:12] | Reserved | 0000 | Always reads as 0000. |
| [11:0] | VOUT_OV_WARN_LIMIT | | Overvoltage threshold for the VOUT pin measurement, expressed in ADC codes. |

VOUT_UV_WARN_LIMIT

Code: 0x43, read/write word. Value after reset: 0x0000.

This command is supported on the [ADM1275-1](#) and the [ADM1275-3](#). The [ADM1275-2](#) does not have a VOUT pin.

Table 15. Bit Descriptions for VOUT_UV_WARN_LIMIT Command

| Bits | Bit Name | Settings | Description |
|---------|--------------------|----------|--|
| [15:12] | Reserved | 0000 | Always reads as 0000. |
| [11:0] | VOUT_UV_WARN_LIMIT | | Undervoltage threshold for the VOUT pin measurement, expressed in ADC codes. |

IOUT_OC_WARN_LIMIT

Code: 0x4A, read/write word. Value after reset: 0x0FFF.

Table 16. Bit Descriptions for IOUT_OC_WARN_LIMIT Command

| Bits | Bit Name | Settings | Description |
|---------|--------------------|----------|--|
| [15:12] | Reserved | 0000 | Always reads as 0000. |
| [11:0] | IOUT_OC_WARN_LIMIT | | Overcurrent threshold for the IOUT measurement through the sense resistor, expressed in ADC codes. |

IOUT_WARN2_LIMIT

Code: 0xD7, read/write word. Value after reset: 0x0000.

Table 17. Bit Descriptions for IOUT_WARN2_LIMIT Command

| Bits | Bit Name | Settings | Description |
|---------|------------------|----------|---|
| [15:12] | Reserved | 0000 | Always reads as 0000. |
| [11:0] | IOUT_WARN2_LIMIT | | Threshold for the IOUT measurement through the sense resistor, expressed in ADC codes. This value can be either an undercurrent or an overcurrent, depending on the state of the IOUT_WARN2_SELECT bit set using the DEVICE_CONFIG command. |

VIN_OV_WARN_LIMIT

Code: 0x57, read/write word. Value after reset: 0x0FFF.

Table 18. Bit Descriptions for VIN_OV_WARN_LIMIT Command

| Bits | Bit Name | Settings | Description |
|---------|-------------------|----------|---|
| [15:12] | Reserved | 0000 | Always reads as 0000. |
| [11:0] | VIN_OV_WARN_LIMIT | | Overvoltage threshold for the SENSE+ pin measurement, expressed in ADC codes. |

VIN_UV_WARN_LIMIT

Code: 0x58, read/write word. Value after reset: 0x0000.

Table 19. Bit Descriptions for VIN_UV_WARN_LIMIT Command

| Bits | Bit Name | Settings | Description |
|---------|-------------------|----------|--|
| [15:12] | Reserved | 0000 | Always reads as 0000. |
| [11:0] | VIN_UV_WARN_LIMIT | | Undervoltage threshold for the SENSE+ pin measurement, expressed in ADC codes. |

STATUS_BYTE

Code: 0x78, read byte. Value after reset: 0x00.

Table 20. Bit Descriptions for STATUS_BYTE Command

| Bits | Bit Name | Behavior | Settings | Description |
|------|-------------------|----------|----------|---|
| 7 | Reserved | | 0 | Always reads as 0. |
| 6 | HOTSWAP_OFF | Live | 0 | The hot-swap gate drive output is enabled. |
| | | | 1 | The hot-swap gate drive output is disabled, and the GATE pin is pulled down. This can be due to, for example, an overcurrent fault that causes the ADM1275 to latch off, an undervoltage condition on the UV pin, or the use of the OPERATION command to turn the output off. |
| 5 | Reserved | | 0 | Always reads as 0. |
| 4 | IOUT_OC_FAULT | Latched | 0 | No overcurrent output fault detected. |
| | | | 1 | The hot-swap controller detected an overcurrent condition and the time limit set by the capacitor on the TIMER pin has elapsed, causing the hot-swap gate drive to shut down. |
| 3 | VIN_UV_FAULT | Latched | 0 | No undervoltage input fault detected on the UV pin. |
| | | | 1 | An undervoltage input fault was detected on the UV pin. |
| 2 | Reserved | | 0 | Always reads as 0. |
| 1 | CML_ERROR | Latched | 0 | No communications error detected on the I ² C/PMBus interface. |
| | | | 1 | An error was detected on the I ² C/PMBus interface. Errors detected are unsupported command, invalid PEC byte, and incorrectly structured message. |
| 0 | NONE_OF_THE_ABOVE | Live | 0 | No other active status bit to be reported by any other status command. |
| | | | 1 | Active status bits are waiting to be read by one or more status commands. |

STATUS_WORD

Code: 0x79, read word. Value after reset: 0x0000.

Table 21. Bit Descriptions for STATUS_WORD Command

| Bits | Bit Name | Behavior | Settings | Description |
|--------|-------------|----------|----------|--|
| 15 | VOUT_STATUS | Live | 0 | There are no active status bits to be read by STATUS_VOUT. |
| | | | 1 | There are one or more active status bits to be read by STATUS_VOUT. |
| 14 | IOUT_STATUS | Live | 0 | There are no active status bits to be read by STATUS_IOUT. |
| | | | 1 | There are one or more active status bits to be read by STATUS_IOUT. |
| 13 | VIN_STATUS | Live | 0 | There are no active status bits to be read by STATUS_INPUT. |
| | | | 1 | There are one or more active status bits to be read by STATUS_INPUT. |
| 12 | MFR_STATUS | Live | 0 | There are no active status bits to be read by STATUS_MFR_SPECIFIC. |
| | | | 1 | There are one or more active status bits to be read by STATUS_MFR_SPECIFIC. |
| 11 | POWER_GOOD# | Live | 0 | The voltage on the FLB pin is above the required threshold, indicating that output power is considered good. This bit is the logical inversion of the PWRGD pin on the part. |
| | | | 1 | The voltage on the FLB pin is below the required threshold, indicating that output power is considered bad. |
| [10:8] | Reserved | | 000 | Always reads as 000. |
| [7:0] | STATUS_BYTE | | | This byte is the same as the byte returned by the STATUS_BYTE command. |

STATUS_VOUT

Code: 0x7A, read byte. Value after reset: 0x00.

This command is supported on the [ADM1275-1](#) and the [ADM1275-3](#). The [ADM1275-2](#) does not have a VOUT pin.**Table 22. Bit Descriptions for STATUS_VOUT Command**

| Bits | Bit Name | Behavior | Settings | Description |
|-------|--------------|----------|----------|---|
| 7 | Reserved | | 0 | Always reads as 0. |
| 6 | VOUT_OV_WARN | Latched | 0 | No overvoltage condition on the output supply detected by the power monitor. |
| | | | 1 | An overvoltage condition on the output supply was detected by the power monitor. |
| 5 | VOUT_UV_WARN | Latched | 0 | No undervoltage condition on the output supply detected by the power monitor. |
| | | | 1 | An undervoltage condition on the output supply was detected by the power monitor. |
| [4:0] | Reserved | | 00000 | Always reads as 00000. |

STATUS_IOUT

Code: 0x7B, read byte. Value after reset: 0x00.

Table 23. Bit Descriptions for STATUS_IOUT Command

| Bits | Bit Name | Behavior | Settings | Description |
|-------|---------------|----------|----------|---|
| 7 | IOUT_OC_FAULT | Latched | 0 | No overcurrent output fault detected. |
| | | | 1 | The hot-swap controller detected an overcurrent condition and the time limit set by the capacitor on the TIMER pin has elapsed, causing the hot-swap gate drive to shut down. |
| 6 | Reserved | | 0 | Always reads as 0. |
| 5 | IOUT_OC_WARN | Latched | 0 | No overcurrent condition on the output supply detected by the power monitor using the IOUT_OC_WARN_LIMIT command. |
| | | | 1 | An overcurrent condition was detected by the power monitor using the IOUT_OC_WARN_LIMIT command. |
| [4:0] | Reserved | | 00000 | Always reads as 00000. |

STATUS_INPUT

Code: 0x7C, read byte. Value after reset: 0x00.

Table 24. Bit Descriptions for STATUS_INPUT Command

| Bits | Bit Name | Behavior | Settings | Description |
|-------|--------------|----------|----------|--|
| 7 | VIN_OV_FAULT | Latched | 0 | No overvoltage detected on the OV pin. |
| | | | 1 | An overvoltage was detected on the OV pin. |
| 6 | VIN_OV_WARN | Latched | 0 | No overvoltage condition on the input supply detected by the power monitor. |
| | | | 1 | An overvoltage condition on the input supply was detected by the power monitor. |
| 5 | VIN_UV_WARN | Latched | 0 | No undervoltage condition on the input supply detected by the power monitor. |
| | | | 1 | An undervoltage condition on the input supply was detected by the power monitor. |
| 4 | VIN_UV_FAULT | Latched | 0 | No undervoltage detected on the UV pin. |
| | | | 1 | An undervoltage was detected on the UV pin. |
| [3:0] | Reserved | | 0000 | Always reads as 0000. |

STATUS_MFR_SPECIFIC

Code: 0x80, read byte. Value after reset: 0x00.

Table 25. Bit Descriptions for STATUS_MFR_SPECIFIC Command

| Bits | Bit Name | Behavior | Settings | Description |
|-------|-------------------|----------|----------|--|
| 7 | FET_HEALTH_BAD | Latched | 0 | FET behavior appears to be as expected. |
| | | | 1 | FET behavior suggests that the FET may be shorted. |
| 6 | UV_CMP_OUT | Live | 0 | Input voltage to UV pin is above threshold. |
| | | | 1 | Input voltage to UV pin is below threshold. |
| 5 | OV_CMP_OUT | Live | 0 | Input voltage to OV pin is below threshold. |
| | | | 1 | Input voltage to OV pin is above threshold. |
| 4 | Reserved | | 0 | Always reads as 0. |
| 3 | HS_INLIM | Latched | 0 | The ADM1275 has not actively limited the current into the load. |
| | | | 1 | The ADM1275 has actively limited current into the load. This bit differs from the IOUT_OC_FAULT bit in that the HS_INLIM bit is set immediately, whereas the IOUT_OC_FAULT bit is not set unless the time limit set by the capacitor on the TIMER pin elapses. |
| [2:1] | HS_SHUTDOWN_CAUSE | Latched | 00 | The ADM1275 is either enabled and working correctly, or has been shut down using the OPERATION command. |
| | | | 01 | An IOUT_OC_FAULT condition occurred that caused the ADM1275 to shut down. |
| | | | 10 | A VIN_UV_FAULT condition occurred that caused the ADM1275 to shut down. |
| | | | 11 | A VIN_OV_FAULT condition occurred that caused the ADM1275 to shut down. |
| 0 | IOUT_WARN2 | Latched | 0 | No overcurrent condition on the output supply detected by the power monitor using the IOUT_WARN2_LIMIT command. |
| | | | 1 | An undercurrent or overcurrent condition on the output supply was detected by the power monitor using the IOUT_WARN2_LIMIT command. The polarity of the threshold condition is set by the IOUT_WARN2_SELECT bit using the DEVICE_CONFIG command. |

READ_VIN

Code: 0x88, read word. Value after reset: 0x0000.

Table 26. Bit Descriptions for READ_VIN Command

| Bits | Bit Name | Settings | Description |
|---------|----------|----------|--|
| [15:12] | Reserved | 0000 | Always reads as 0000. |
| [11:0] | VIN | | Input voltage from the SENSE+ pin measurement, expressed in ADC codes. |

READ_VOUT

Code: 0x8B, read word. Value after reset: 0x0000.

This command is supported on the [ADM1275-1](#) and the [ADM1275-3](#). The [ADM1275-2](#) does not have a VOUT pin.

Table 27. Bit Descriptions for READ_VOUT Command

| Bits | Bit Name | Settings | Description |
|---------|----------|----------|---|
| [15:12] | Reserved | 0000 | Always reads as 0000. |
| [11:0] | VOUT | | Output voltage from the VOUT pin measurement, expressed in ADC codes. |

READ_IOUT

Code: 0x8C, read word. Value after reset: 0x0000.

Table 28. Bit Descriptions for READ_IOUT Command

| Bits | Bit Name | Settings | Description |
|---------|----------|----------|---|
| [15:12] | Reserved | 0000 | Always reads as 0000. |
| [11:0] | IOUT | | Output current from the measurement through the sense resistor. |

PMBUS_REVISION

Code: 0x98, read byte. Value after reset: 0x11.

Table 29. Bit Descriptions for PMBUS_REVISION Command

| Bits | Bit Name | Settings | Description |
|-------|------------------|----------|--|
| [7:4] | Part I Revision | 0001 | Always reads as 0001, PMBus Specification Part I, Revision 1.1. |
| [3:0] | Part II Revision | 0001 | Always reads as 0001, PMBus Specification Part II, Revision 1.1. |

MFR_ID

Code: 0x99, block read. Value after reset: 0x03 + ASCII "ADI".

Table 30. Bit Descriptions for MFR_ID Command

| Byte | Byte Name | Value | Description |
|------|-------------|-------------|---|
| 0 | Byte count | 0x03 | Always reads as 0x03, the number of data bytes that the block read command should expect to read. |
| 1 | Character 1 | 0x41 or "A" | Always reads as 0x41. |
| 2 | Character 2 | 0x44 or "D" | Always reads as 0x44. |
| 3 | Character 3 | 0x49 or "I" | Always reads as 0x49. |

MFR_MODEL

Code: 0x9A, block read. Value after reset: 0x09 + ASCII "ADM1275-x".

Table 31. Bit Descriptions for MFR_MODEL Command

| Byte | Byte Name | Value | Description |
|------|-------------|-------------|---|
| 0 | Byte count | 0x09 | Always reads as 0x09, the number of data bytes that the block read command should expect to read. |
| 1 | Character 1 | 0x41 or "A" | Always reads as 0x41. |
| 2 | Character 2 | 0x44 or "D" | Always reads as 0x44. |
| 3 | Character 3 | 0x4D or "M" | Always reads as 0x4D. |
| 4 | Character 4 | 0x31 or "1" | Always reads as 0x31. |
| 5 | Character 5 | 0x32 or "2" | Always reads as 0x32. |
| 6 | Character 6 | 0x37 or "7" | Always reads as 0x37. |
| 7 | Character 7 | 0x35 or "5" | Always reads as 0x35. |
| 8 | Character 8 | 0x2D or "-" | Always reads as 0x2D. |

| Byte | Byte Name | Value | Description |
|------|-------------|-------------|---|
| 9 | Character 9 | 0x31 or "1" | Always reads as 0x31 on the ADM1275-1 . |
| | | 0x32 or "2" | Always reads as 0x32 on the ADM1275-2 . |
| | | 0x33 or "3" | Always reads as 0x33 on the ADM1275-3 . |

MFR_REVISION

Code: 0x9B, block read. Value after reset: 0x01 + ASCII "1".

Table 32. Bit Descriptions for MFR_REVISION Command

| Byte | Byte Name | Value | Description |
|------|-------------|-------------|---|
| 0 | Byte count | 0x01 | Always reads as 0x01, the number of data bytes that the block read command should expect to read. |
| 1 | Character 1 | 0x31 or "1" | Always reads as 0x31, Revision 1 of the ADM1275 . |

PEAK_IOUT

Code: 0xD0, read/write word. Value after reset: 0x0000 (writing 0x0000 clears the peak value).

Table 33. Bit Descriptions for PEAK_IOUT Command

| Bits | Bit Name | Settings | Description |
|---------|-----------|----------|--|
| [15:12] | Reserved | 0000 | Always reads as 0000. |
| [11:0] | PEAK_IOUT | | Returns the peak IOUT current since the register was last cleared. |

PEAK_VIN

Code: 0xD1, read/write word. Value after reset: 0x0000 (writing 0x0000 clears the peak value).

Table 34. Bit Descriptions for PEAK_VIN Command

| Bits | Bit Name | Settings | Description |
|---------|----------|----------|---|
| [15:12] | Reserved | 0000 | Always reads as 0000. |
| [11:0] | PEAK_VIN | | Returns the peak VIN voltage since the register was last cleared. |

PEAK_VOUT

Code: 0xD2, read/write word. Value after reset: 0x0000 (writing 0x0000 clears the peak value).

This command is supported on the [ADM1275-1](#) and the [ADM1275-3](#). The [ADM1275-2](#) does not have a VOUT pin.

Table 35. Bit Descriptions for PEAK_VOUT Command

| Bits | Bit Name | Settings | Description |
|---------|-----------|----------|--|
| [15:12] | Reserved | 0000 | Always reads as 0000. |
| [11:0] | PEAK_VOUT | | Returns the peak VOUT voltage since the register was last cleared. |

PMON_CONTROL

Code: 0xD3, read/write byte. Value after reset: 0x00.

Table 36. Bit Descriptions for PMON_CONTROL Command

| Bits | Bit Name | Settings | Description |
|-------|----------|----------|---|
| [7:1] | Reserved | 0000000 | Always reads as 0000000. |
| 0 | CONVERT | 0 | Default. Power monitor is not running. |
| | | 1 | Start the sampling of current and voltage with the power monitor. In single-shot mode, this bit clears itself after one complete cycle. In continuous mode, this bit must be written to 0 to stop sampling. |

PMON_CONFIG

Code: 0xD4, read/write byte. Value after reset: 0x2C.

Modifying the power monitor settings while the power monitor is sampling is not supported. The power monitor must be stopped before any setting in Table 37 is changed to ensure correct operation and to prevent any potential spurious data and status alerts being generated.

Table 37. Bit Descriptions for PMON_CONFIG Command

| Bits | Bit Name | Settings | Description |
|-------|-----------------|----------|--|
| 7 | PMON_MODE | 0 | Default. This setting selects single-shot sampling mode. |
| | | 1 | This setting selects continuous sampling mode. |
| 6 | VIN_VOUT_SELECT | 0 | Default. The power monitor will sample the input voltage on the SENSE+ pin. On the ADM1275-2 , this bit should always be written as 0. |
| | | 1 | The power monitor will sample the output voltage on the VOUT pin. |
| 5 | VRANGE | 0 | Sets the voltage input range from 0 V to 6 V (low input voltage range). |
| | | 1 | Default. Sets the voltage input range from 0 V to 20 V (high input voltage range). |
| 4 | Reserved | 0 | Reserved. This bit must always be written as 0. |
| 3 | Reserved | 1 | Default. This bit must be set to 1 for the power monitor current sense to operate correctly. |
| [2:0] | AVERAGING | 000 | Disables sample averaging for current and voltage. |
| | | 001 | Sets sample averaging for current and voltage to 2 samples. |
| | | 010 | Sets sample averaging for current and voltage to 4 samples. |
| | | 011 | Sets sample averaging for current and voltage to 8 samples. |
| | | 100 | Sets sample averaging for current and voltage to 16 samples. |
| | | 101 | Sets sample averaging for current and voltage to 32 samples. |
| | | 110 | Sets sample averaging for current and voltage to 64 samples. |
| | | 111 | Sets sample averaging for current and voltage to 128 samples. |

ALERT1_CONFIG

Code: 0xD5, read/write word. Value after reset: 0x0000.

This command is supported on the [ADM1275-1](#) and the [ADM1275-2](#). The [ADM1275-3](#) does not have a GPO1/ALERT1/CONV pin.

Table 38. Bit Descriptions for ALERT1_CONFIG Command

| Bits | Bit Name | Settings | Description |
|------|--------------------|----------|--|
| 15 | FET_HEALTH_BAD_EN1 | 0 | Default. Disables generation of SMBAlert when the FET_HEALTH_BAD bit is set. |
| | | 1 | Generate SMBAlert when the FET_HEALTH_BAD bit is set. |
| 14 | IOUT_OC_FAULT_EN1 | 0 | Default. Disables generation of SMBAlert when the IOUT_OC_FAULT bit is set. |
| | | 1 | Generate SMBAlert when the IOUT_OC_FAULT bit is set. |
| 13 | VIN_OV_FAULT_EN1 | 0 | Default. Disables generation of SMBAlert when the VIN_OV_FAULT bit is set. |
| | | 1 | Generate SMBAlert when the VIN_OV_FAULT bit is set. |
| 12 | VIN_UV_FAULT_EN1 | 0 | Default. Disables generation of SMBAlert when the VIN_UV_FAULT bit is set. |
| | | 1 | Generate SMBAlert when the VIN_UV_FAULT bit is set. |
| 11 | CML_ERROR_EN1 | 0 | Default. Disables generation of SMBAlert when the CML_ERROR bit is set. |
| | | 1 | Generate SMBAlert when the CML_ERROR bit is set. |
| 10 | IOUT_OC_WARN_EN1 | 0 | Default. Disables generation of SMBAlert when the IOUT_OC_WARN bit is set. |
| | | 1 | Generate SMBAlert when the IOUT_OC_WARN bit is set. |
| 9 | IOUT_WARN2_EN1 | 0 | Default. Disables generation of SMBAlert when the IOUT_WARN2 bit is set. |
| | | 1 | Generate SMBAlert when the IOUT_WARN2 bit is set. |
| 8 | VIN_OV_WARN_EN1 | 0 | Default. Disables generation of SMBAlert when the VIN_OV_WARN bit is set. |
| | | 1 | Generate SMBAlert when the VIN_OV_WARN bit is set. |
| 7 | VIN_UV_WARN_EN1 | 0 | Default. Disables generation of SMBAlert when the VIN_UV_WARN bit is set. |
| | | 1 | Generate SMBAlert when the VIN_UV_WARN bit is set. |
| 6 | VOUT_OV_WARN_EN1 | 0 | Default. Disables generation of SMBAlert when the VOUT_OV_WARN bit is set. |
| | | 1 | Generate SMBAlert when the VOUT_OV_WARN bit is set. |

| Bits | Bit Name | Settings | Description |
|------|-------------------|----------|--|
| 5 | VOUT_UV_WARN_EN1 | 0 | Default. Disables generation of SMBAlert when the VOUT_UV_WARN bit is set. |
| | | 1 | Generate SMBAlert when the VOUT_UV_WARN bit is set. |
| 4 | HS_INLIM_EN1 | 0 | Default. Disables generation of SMBAlert when the HS_INLIM bit is set. |
| | | 1 | Generate SMBAlert when the HS_INLIM bit is set. |
| 3 | INVERT_SMBALERT_1 | 0 | Default. SMBAlert is active low when a fault/warning bit that is enabled becomes set. |
| | | 1 | SMBAlert is active high when a fault/warning bit that is enabled becomes set. |
| 2 | CONVERT_EN | 0 | Default. GPO1/ $\overline{\text{ALERT1}}$ /CONV is configured as an output pin. |
| | | 1 | GPO1/ $\overline{\text{ALERT1}}$ /CONV is configured as an input pin. All other settings in ALERT1_CONFIG are ignored. |
| 1 | GPO1_EN | 0 | Default. GPO1/ $\overline{\text{ALERT1}}$ /CONV can be configured as either a power monitor convert input or an SMBAlert output. |
| | | 1 | GPO1/ $\overline{\text{ALERT1}}$ /CONV is configured as a general-purpose output unless CONVERT_EN is set to 1. |
| 0 | GPO1_DATA | 0 | Default. Sets GPO1/ $\overline{\text{ALERT1}}$ /CONV low when configured as a general-purpose output. |
| | | 1 | Sets GPO1/ $\overline{\text{ALERT1}}$ /CONV high when configured as a general-purpose output. |

ALERT2_CONFIG

Code: 0xD6, read/write word. Value after reset: 0x8000.

This command is supported on the [ADM1275-1](#) and the [ADM1275-3](#). The [ADM1275-2](#) does not have a GPO2/ $\overline{\text{ALERT2}}$ pin.

Table 39. Bit Descriptions for ALERT2_CONFIG Command

| Bits | Bit Name | Settings | Description |
|------|--------------------|----------|--|
| 15 | FET_HEALTH_BAD_EN2 | 0 | Disables generation of SMBAlert when the FET_HEALTH_BAD bit is set. |
| | | 1 | Default. Generate SMBAlert when the FET_HEALTH_BAD bit is set. This bit is active from power-up so that a FET problem can be detected and flagged immediately without the need for software to set this bit. |
| 14 | IOUT_OC_FAULT_EN2 | 0 | Default. Disables generation of SMBAlert when the IOUT_OC_FAULT bit is set. |
| | | 1 | Generate SMBAlert when the IOUT_OC_FAULT bit is set. |
| 13 | VIN_OV_FAULT_EN2 | 0 | Default. Disables generation of SMBAlert when the VIN_OV_FAULT bit is set. |
| | | 1 | Generate SMBAlert when the VIN_OV_FAULT bit is set. |
| 12 | VIN_UV_FAULT_EN2 | 0 | Default. Disables generation of SMBAlert when the VIN_UV_FAULT bit is set. |
| | | 1 | Generate SMBAlert when the VIN_UV_FAULT bit is set. |
| 11 | CML_ERROR_EN2 | 0 | Default. Disables generation of SMBAlert when the CML_ERROR bit is set. |
| | | 1 | Generate SMBAlert when the CML_ERROR bit is set. |
| 10 | IOUT_OC_WARN_EN2 | 0 | Default. Disables generation of SMBAlert when the IOUT_OC_WARN bit is set. |
| | | 1 | Generate SMBAlert when the IOUT_OC_WARN bit is set. |
| 9 | IOUT_WARN2_EN2 | 0 | Default. Disables generation of SMBAlert when the IOUT_WARN2 bit is set. |
| | | 1 | Generate SMBAlert when the IOUT_WARN2 bit is set. |
| 8 | VIN_OV_WARN_EN2 | 0 | Default. Disables generation of SMBAlert when the VIN_OV_WARN bit is set. |
| | | 1 | Generate SMBAlert when the VIN_OV_WARN bit is set. |
| 7 | VIN_UV_WARN_EN2 | 0 | Default. Disables generation of SMBAlert when the VIN_UV_WARN bit is set. |
| | | 1 | Generate SMBAlert when the VIN_UV_WARN bit is set. |
| 6 | VOUT_OV_WARN_EN2 | 0 | Default. Disables generation of SMBAlert when the VOUT_OV_WARN bit is set. |
| | | 1 | Generate SMBAlert when the VOUT_OV_WARN bit is set. |
| 5 | VOUT_UV_WARN_EN2 | 0 | Default. Disables generation of SMBAlert when the VOUT_UV_WARN bit is set. |
| | | 1 | Generate SMBAlert when the VOUT_UV_WARN bit is set. |
| 4 | HS_INLIM_EN2 | 0 | Default. Disables generation of SMBAlert when the HS_INLIM bit is set. |
| | | 1 | Generate SMBAlert when the HS_INLIM bit is set. |
| 3 | INVERT_SMBALERT_2 | 0 | Default. SMBAlert is active low when a fault/warning bit that is enabled becomes set. |
| | | 1 | SMBAlert is active high when a fault/warning bit that is enabled becomes set. |
| 2 | Reserved | 0 | Always reads as 0. |

| Bits | Bit Name | Settings | Description |
|------|-----------|----------|---|
| 1 | GPO2_EN | 0 | Default. GPO/ALERT2 is configured as an SMBAlert output. |
| | | 1 | GPO/ALERT2 is configured as a general-purpose output. |
| 0 | GPO2_DATA | 0 | Default. Sets GPO/ALERT2 low when configured as a general-purpose output. |
| | | 1 | Sets GPO/ALERT2 high when configured as a general-purpose output. |

DEVICE_CONFIG

Code: 0xD8, read/write byte. Value after reset: 0x00.

Table 40. Bit Descriptions for DEVICE_CONFIG Command

| Bits | Bit Name | Settings | Description |
|-------|-------------------|----------|---|
| 7 | OC_GLITCH_TIME | 0 | Default. The long duration glitch filter is used when a severe overcurrent fault is detected. |
| | | 1 | The short duration glitch filter is used when a severe overcurrent fault is detected. |
| 6 | FLB_DISABLE | 0 | Default. Foldback is enabled and can affect the hot-swap current sense limit. |
| | | 1 | Foldback is disabled and does not affect the hot-swap current sense limit. This setting can be useful if the sole purpose of the FLB pin is to act as a power-good input. |
| 5 | OPERATION_CMD_EN | 0 | Default. The OPERATION command is disabled, and the ADM1275 issues a NACK if the command is received. This setting provides some protection against a card accidentally turning itself off. |
| | | 1 | The OPERATION command is enabled, and the ADM1275 responds to it. |
| 4 | IOUT_WARN2_SELECT | 0 | Default. Configures IOUT_WARN2_LIMIT as an undercurrent threshold. |
| | | 1 | Configures IOUT_WARN2_LIMIT as an overcurrent threshold. |
| [3:0] | Reserved | 0000 | Always reads as 0000. |

POWER_CYCLE

Code: 0xD9, send byte, no data.

OUTLINE DIMENSIONS

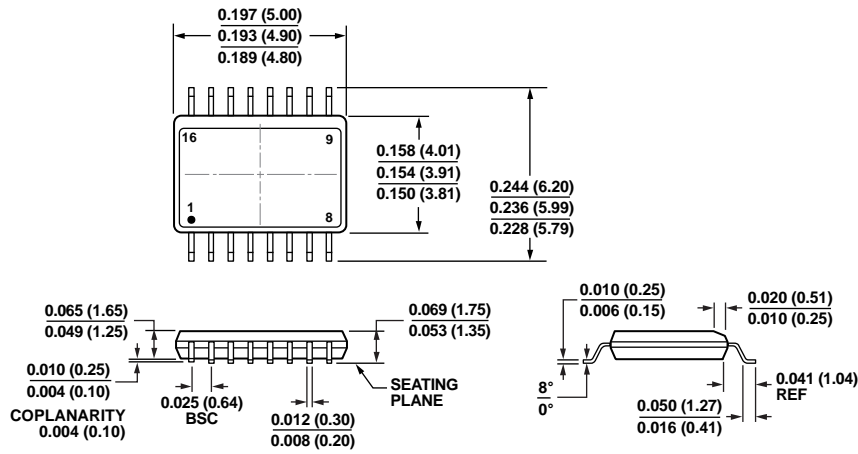

COMPLIANT TO JEDEC STANDARDS MO-137-AB
 CONTROLLING DIMENSIONS ARE IN INCHES; MILLIMETER DIMENSIONS
 (IN PARENTHESES) ARE ROUNDED-OFF INCH EQUIVALENTS FOR
 REFERENCE ONLY AND ARE NOT APPROPRIATE FOR USE IN DESIGN.

Figure 66. 16-Lead Shrink Small Outline Package [QSOP]
 (RQ-16)

Dimensions shown in inches and (millimeters)

01-28-2008-A

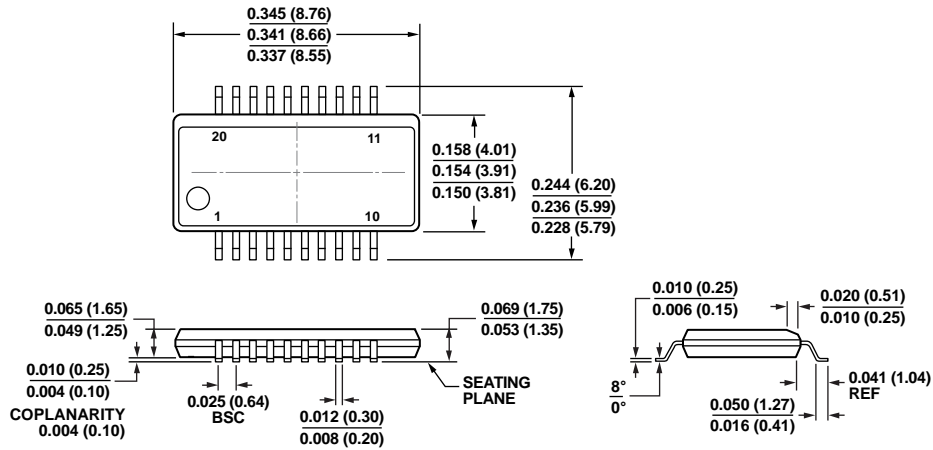

COMPLIANT TO JEDEC STANDARDS MO-137-AD
 CONTROLLING DIMENSIONS ARE IN INCHES; MILLIMETER DIMENSIONS
 (IN PARENTHESES) ARE ROUNDED-OFF INCH EQUIVALENTS FOR
 REFERENCE ONLY AND ARE NOT APPROPRIATE FOR USE IN DESIGN.

Figure 67. 20-Lead Shrink Small Outline Package [QSOP]
 (RQ-20)

Dimensions shown in inches and (millimeters)

08-19-2008-A

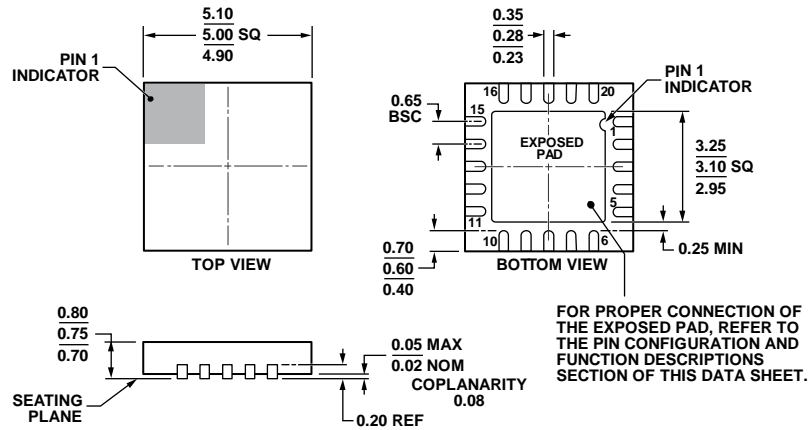

COMPLIANT TO JEDEC STANDARDS MO-220-WHHC.

Figure 68. 20-Lead Lead Frame Chip Scale Package [LFCSP_WQ]
 5 mm × 5 mm Body, Very Very Thin Quad
 (CP-20-9)
 Dimensions shown in millimeters

111908-A

ORDERING GUIDE

| Model ¹ | Temperature Range | Package Description | Package Option |
|--------------------|-------------------|--|----------------|
| ADM1275-1ARQZ | -40°C to +85°C | 20-Lead Shrink Small Outline Package [QSOP] | RQ-20 |
| ADM1275-1ARQZ-R7 | -40°C to +85°C | 20-Lead Shrink Small Outline Package [QSOP] | RQ-20 |
| ADM1275-1ACPZ | -40°C to +85°C | 20-Lead Lead Frame Chip Scale Package [LFCSP_WQ] | CP-20-9 |
| ADM1275-1ACPZ-R7 | -40°C to +85°C | 20-Lead Lead Frame Chip Scale Package [LFCSP_WQ] | CP-20-9 |
| ADM1275-2ARQZ | -40°C to +85°C | 16-Lead Shrink Small Outline Package [QSOP] | RQ-16 |
| ADM1275-2ARQZ-R7 | -40°C to +85°C | 16-Lead Shrink Small Outline Package [QSOP] | RQ-16 |
| ADM1275-3ARQZ | -40°C to +85°C | 20-Lead Shrink Small Outline Package [QSOP] | RQ-20 |
| ADM1275-3ARQZ-R7 | -40°C to +85°C | 20-Lead Shrink Small Outline Package [QSOP] | RQ-20 |
| ADM1275-3ACPZ | -40°C to +85°C | 20-Lead Lead Frame Chip Scale Package [LFCSP_WQ] | CP-20-9 |
| ADM1275-3ACPZ-R7 | -40°C to +85°C | 20-Lead Lead Frame Chip Scale Package [LFCSP_WQ] | CP-20-9 |
| EVAL-ADM1275EBZ | | Evaluation Board | |

¹ Z = RoHS Compliant Part.

NOTES

I²C refers to a communications protocol originally developed by Philips Semiconductors (now NXP Semiconductors).