

8-Mbit (1M × 8-Bit/512K × 16-Bit), 3 V, Boot Sector Flash

Distinctive Characteristics

Architectural Advantages

- Single Power Supply Operation
 - Full voltage range: 2.7 to 3.6 volt read and write operations for battery-powered applications
- Manufactured on 110 nm Process Technology
 - Fully compatible with 200 nm S29AL008D
- Secured Silicon Sector region
 - 128-word/256-byte sector for permanent, secure identification through an 8-word/16-byte random Electronic Serial Number accessible through a command sequence
 - May be programmed and locked at the factory or by the customer
- Flexible Sector Architecture
 - One 16 Kbyte, two 8 Kbyte, one 32 Kbyte, and fifteen 64 Kbyte sectors (byte mode)
 - One 8 Kword, two 4 Kword, one 16 Kword, and fifteen 32 Kword sectors (word mode)
- Sector Group Protection Features
 - A hardware method of locking a sector to prevent any program or erase operations within that sector
 - Sectors can be locked in-system or via programming equipment
 - Temporary Sector Unprotect feature allows code changes in previously locked sectors
- Unlock Bypass Program Command
 - Reduces overall programming time when issuing multiple program command sequences
- Top or Bottom Boot Block Configurations Available
- Compatibility with JEDEC standards
 - Pinout and software compatible with single-power supply Flash
 - Superior inadvertent write protection

Performance Characteristics

- High Performance
 - Access times as fast as 55 ns
 - Extended temperature range (–40°C to +125°C)
 - Automotive AEC-Q100 Grade 3 (–40 °C to +85 °C)
 - Automotive AEC-Q100 Grade 1 (–40 °C to +125 °C)
- Ultra Low Power Consumption (typical values at 5 MHz)
 - 0.2 µA Automatic Sleep mode current
 - 0.2 µA standby mode current
 - 7 mA read current
 - 20 mA program/erase current
- Cycling Endurance: 1,000,000 cycles per sector typical
- Data Retention: 20 years typical

Package Options

- 48-ball Fine-pitch BGA
- 48-pin TSOP

Software Features

- CFI (Common Flash Interface) Compliant
 - Provides device-specific information to the system, allowing host software to easily reconfigure for different Flash devices
- Erase Suspend/Erase Resume
 - Suspends an erase operation to read data from, or program data to, a sector that is not being erased, then resumes the erase operation
- Data# Polling and Toggle Bits
 - Provides a software method of detecting program or erase operation completion

Hardware Features

- Ready/Busy# Pin (RY/BY#)
 - Provides a hardware method of detecting program or erase cycle completion
- Hardware Reset Pin (RESET#)
 - Hardware method to reset the device to reading array data
- WP# input pin
 - For boot sector devices: at V_{IL} , protects first or last 16 Kbyte sector depending on boot configuration (top boot or bottom boot)

General Description

The S29AL008J is a 8 Mbit, 3.0 Volt-only Flash memory organized as 1,048,576 bytes or 524,288 words. The device is offered in 48-ball Fine-pitch BGA (0.8 mm pitch), and 48-pin TSOP packages. The word-wide data (x16) appears on DQ15–DQ0; the byte-wide (x8) data appears on DQ7–DQ0. This device is designed to be programmed in-system with the standard system 3.0 volt V_{CC} supply. A 12.0 V V_{PP} or 5.0 V_{CC} are not required for write or erase operations. The device can also be programmed in standard EPROM programmers.

The device offers access times of up to 55 ns allowing high speed microprocessors to operate without wait states. To eliminate bus contention the device has separate chip enable (CE#), write enable (WE#) and output enable (OE#) controls.

The device requires only a **single 3.0 volt power supply** for both read and write functions. Internally generated and regulated voltages are provided for the program and erase operations.

The S29AL008J is entirely command set compatible with the **JEDEC single-power-supply Flash standard**. Commands are written to the command register using standard microprocessor write timings. Register contents serve as input to an internal state-machine that controls the erase and programming circuitry. Write cycles also internally latch addresses and data needed for the programming and erase operations. Reading data out of the device is similar to reading from other Flash or EPROM devices.

Device programming occurs by executing the program command sequence. This initiates the **Embedded Program** algorithm—an internal algorithm that automatically times the program pulse widths and verifies proper cell margin. The **Unlock Bypass** mode facilitates faster programming times by requiring only two write cycles to program data instead of four.

Device erasure occurs by executing the erase command sequence. This initiates the **Embedded Erase** algorithm—an internal algorithm that automatically preprograms the array (if it is not already programmed) before executing the erase operation. During erase, the device automatically times the erase pulse widths and verifies proper cell margin.

The host system can detect whether a program or erase operation is complete by observing the RY/BY# pin, or by reading the DQ7 (Data# Polling) and DQ6 (toggle) **status bits**. After a program or erase cycle has been completed, the device is ready to read array data or accept another command.

The **sector erase architecture** allows memory sectors to be erased and reprogrammed without affecting the data contents of other sectors. The device is fully erased when shipped from the factory.

Hardware data protection measures include a low V_{CC} detector that automatically inhibits write operations during power transitions. The **hardware sector protection** feature disables both program and erase operations in any combination of the sectors of memory. This can be achieved in-system or via programming equipment.

The **Erase Suspend/Erase Resume** feature enables the user to put erase on hold for any period of time to read data from, or program data to, any sector that is not selected for erasure. True background erase can thus be achieved.

The **hardware RESET# pin** terminates any operation in progress and resets the internal state machine to reading array data. The RESET# pin may be tied to the system reset circuitry. A system reset would thus also reset the device, enabling the system microprocessor to read the boot-up firmware from the Flash memory.

The device offers two power-saving features. When addresses have been stable for a specified amount of time, the device enters the **automatic sleep mode**. The system can also place the device into the **standby mode**. Power consumption is greatly reduced in both these modes.

Cypress Flash technology combines years of Flash memory manufacturing experience to produce the highest levels of quality, reliability and cost effectiveness. The device electrically erases all bits within a sector simultaneously via Fowler-Nordheim tunneling. The data is programmed using hot electron injection.

Contents

1. Product Selector Guide	4	13. Operating Ranges	33
2. Block Diagram	4	14. DC Characteristics	34
3. Connection Diagrams	5	14.1 CMOS Compatible	34
3.1 Special Handling Instructions	5	15. Test Conditions	35
4. Pin Configuration	6	16. Key to Switching Waveforms	35
5. Logic Symbol	6	17. AC Characteristics	36
6. Ordering Information	7	17.1 Read Operations	36
6.1 S29AL008J Standard Products	7	17.2 Hardware Reset (RESET#)	37
7. Device Bus Operations	9	17.3 Word/Byte Configuration (BYTE#)	38
7.1 Word/Byte Configuration	10	17.4 Erase/Program Operations	39
7.2 Requirements for Reading Array Data	10	17.5 Temporary Sector Group Unprotect	42
7.3 Writing Commands/Command Sequences	10	17.6 Alternate CE# Controlled Erase/Program Operations	43
7.4 Program and Erase Operation Status	10	18. Erase and Programming Performance	44
7.5 Standby Mode	10	19. TSOP and BGA Pin Capacitance	44
7.6 Automatic Sleep Mode	11	20. Physical Dimensions	45
7.7 RESET#: Hardware Reset Pin	11	20.1 48-Pin TSOP (18.4 mm × 12.0 mm × 1.2 mm) Package Outline	45
7.8 Output Disable Mode	11	20.2 48-Ball VFBGA (8.15 mm × 6.15 mm × 1.00 mm) Package Outline	46
7.9 Autoselect Mode	13	21. Revision History	47
7.10 Sector Group Protection/Unprotection	14	Document History Page	47
7.11 Temporary Sector Group Unprotect	15	Sales, Solutions, and Legal Information	50
8. Secured Silicon Sector Flash Memory Region	17	Worldwide Sales and Design Support	50
8.1 Factory Locked: Secured Silicon Sector Programmed and Protected at the Factory	17	Products	50
8.2 Customer Lockable: Secured Silicon Sector NOT Programmed or Protected at the Factory	17	PSoC® Solutions	50
9. Common Flash Memory Interface (CFI)	19	Cypress Developer Community	50
9.1 Hardware Data Protection	21	Technical Support	50
10. Command Definitions	22		
10.1 Reading Array Data	22		
10.2 Reset Command	22		
10.3 Autoselect Command Sequence	22		
10.4 Enter Secured Silicon Sector/Exit Secured Silicon Sector Command Sequence	23		
10.5 Word/Byte Program Command Sequence	23		
10.6 Unlock Bypass Command Sequence	23		
10.7 Chip Erase Command Sequence	24		
10.8 Sector Erase Command Sequence	25		
10.9 Erase Suspend/Erase Resume Commands	25		
10.10 Command Definitions Table	26		
11. Write Operation Status	28		
11.1 DQ7: Data# Polling	28		
11.2 RY/BY#: Ready/Busy#	29		
11.3 DQ6: Toggle Bit I	29		
11.4 DQ2: Toggle Bit II	29		
11.5 Reading Toggle Bits DQ6/DQ2	30		
11.6 DQ5: Exceeded Timing Limits	31		
11.7 DQ3: Sector Erase Timer	31		
12. Absolute Maximum Ratings	32		

1. Product Selector Guide

Family Part Number		S29AL008J	
Speed Option	Voltage Range: $V_{CC} = 2.7\text{-}3.6\text{ V}$	–	70
	$V_{CC} = 3.0\text{-}3.6\text{ V}$	55	–
Max access time, ns (t_{ACC})		55	70
Max CE# access time, ns (t_{CE})		55	70
Max CE# access time, ns (t_{OE})		30	30

Note
See AC Characteristics on page 36 for full specifications.

2. Block Diagram

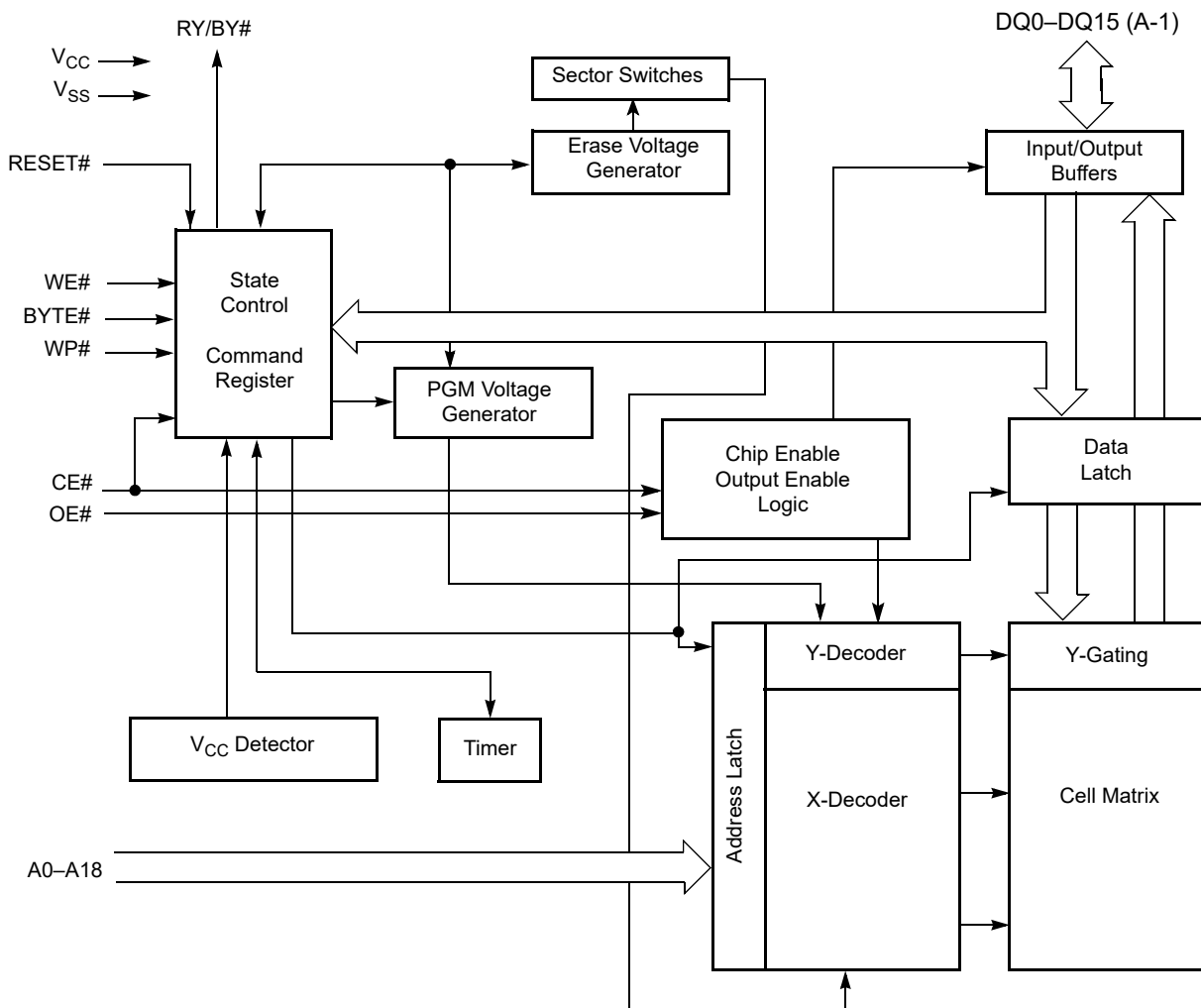

3. Connection Diagrams

Figure 1. 48-pin Standard TSOP (TS048)



Figure 2. 48-ball Fine-pitch BGA (VBK048)



3.1 Special Handling Instructions

Special handling is required for Flash Memory products in BGA packages.

Flash memory devices in BGA packages may be damaged if exposed to ultrasonic cleaning methods. The package and/or data integrity may be compromised if the package body is exposed to temperatures above 150 °C for prolonged periods of time.

4. Pin Configuration

A0–A18	19 addresses
DQ0–DQ14	15 data inputs/outputs
DQ15/A-1	DQ15 (data input/output, word mode), A-1 (LSB address input, byte mode)
BYTE#	Selects 8-bit or 16-bit mode
CE#	Chip enable
OE#	Output enable
WE#	Write enable
WP#	Write protect: The WP# contains an internal pull-up; when unconnected, WP is at V_{IH} .
RESET#	Hardware reset
RY/BY#	Ready/Busy output
V_{CC}	3.0 volt-only single power supply (see Product Selector Guide on page 4 for speed options and voltage supply tolerances)
V_{SS}	Device ground
NC	Pin not connected internally

5. Logic Symbol



6. Ordering Information

6.1 S29AL008J Standard Products

Cypress standard products are available in several packages and operating ranges. The order number (Valid Combination) is formed by a combination of the elements below.

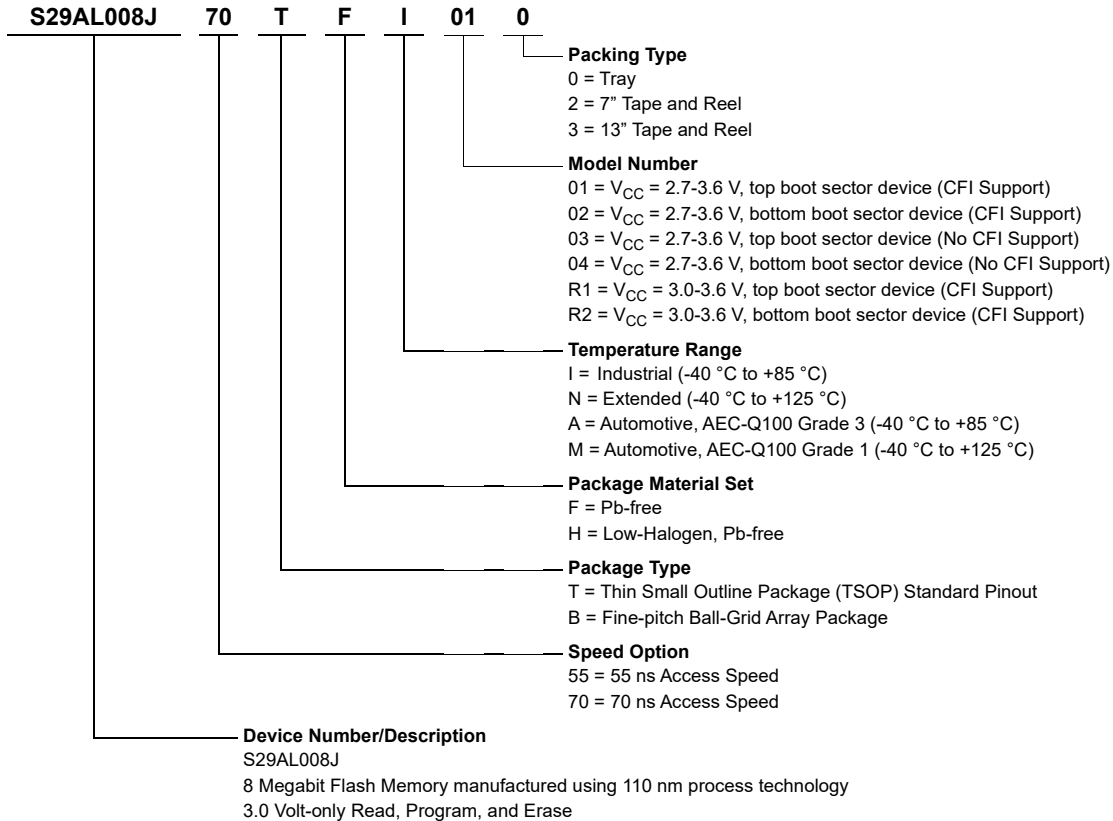

Valid Combinations

Valid Combinations list configurations planned to be supported in volume for this device. Consult your local sales office to confirm availability of specific valid combinations and to check on newly released combinations.

S29AL008J Valid Combination					Package Description	
Device Number	Speed Option	Package Type, Material, and Temperature Range	Model Number	Packing Type		
S29AL008J	55	TFI, TFN	R1, R2	0, 3 (Note 1)	TS048 (Note 3)	TSOP
		BFI, BFN, BHI, BHN		0, 2, 3 (Note 1)	VBK048 (Note 4)	Fine-Pitch BGA
	70	TFI, TFN	01, 02	0, 3 (Note 1)	TS048 (Note 3)	TSOP
		BFI, BFN, BHI, BHN		0, 2, 3 (Note 1)	VBK048 (Note 4)	Fine-Pitch BGA
		TFI	03, 04	0, 3 (Note 1)	TS048 (Note 3)	TSOP
		BFN, BHN		0, 2, 3 (Note 1)	VBK048 (Note 4)	Fine-Pitch BGA

Notes

1. Type 0 is standard. Specify other options as required.
2. Type 1 is standard. Specify other options as required.
3. TSOP package markings omit packing type designator from ordering part number.
4. BGA package marking omits leading S29 and packing type designator from ordering part number.

Valid Combinations – Automotive Grade / AEC-Q100

The following table lists configurations that are Automotive Grade / AEC-Q100 qualified and are planned to be available in volume. The table will be updated as new combinations are released. Contact your local sales representative to confirm availability of specific combinations and to check on newly released combinations.

S29AL008J Valid Combination				Package Description		
Device Number	Speed Options	Package Type, Material, and Temperature Range	Model Number	Packing Type		
S29AL008J	55	TFA	R2	0, 3 (Note 1)	TS048 (Note 3)	TSOP
	70	BFA, BFM	01, 02	0, 3 (Note 1)	VBK048 (Note 4)	Fine-Pitch BGA
	70	TFA	02	0, 3 (Note 1)	TS048 (Note 3)	TSOP
	70	TFM	02	0	TS048	TSOP

Production Part Approval Process (PPAP) support is only provided for AEC-Q100 grade products.

Products to be used in end-use applications that require ISO/TS-16949 compliance must be AEC-Q100 grade products in combination with PPAP. Non-AEC-Q100 grade products are not manufactured or documented in full compliance with ISO/TS-16949 requirements.

AEC-Q100 grade products are also offered without PPAP support for end-use applications that do not require ISO/TS-16949 compliance.

7. Device Bus Operations

This section describes the requirements and use of the device bus operations, which are initiated through the internal command register. The command register itself does not occupy any addressable memory location. The register is composed of latches that store the commands, along with the address and data information needed to execute the command. The contents of the register serve as inputs to the internal state machine. The state machine outputs dictate the function of the device. The following table lists the device bus operations, the inputs and control levels they require, and the resulting output. The following subsections describe each of these operations in further detail.

Table 1. S29AL008J Device Bus Operations

Operation	CE#	OE#	WE#	RESET#	WP#	Addresses (Note 1)	DQ0– DQ7	DQ8–DQ15	
								BYTE# = V _{IH}	BYTE# = V _{IL}
Read	L	L	H	H	X	A _{IN}	D _{OUT}	D _{OUT}	DQ8–DQ14 = High-Z, DQ15 = A-1
Write	L	H	L	H	(Note 3)	A _{IN}	(Note 4)	(Note 4)	
Standby	V _{CC} ± 0.3 V	X	X	V _{CC} ± 0.3 V	X	X	High-Z	High-Z	High-Z
Output Disable	L	H	H	H	X	X	High-Z	High-Z	High-Z
Reset	X	X	X	L	X	X	High-Z	High-Z	High-Z
Sector Group Protect (2) (3)	L	H	L	V _{ID}	H	Sector Address, A6 = L, A3 = A2 = L, A1 = H, A0 = L	(Note 4)	X	X
Sector Group Unprotect (2) (3)	L	H	L	V _{ID}	H	Sector Address, A6 = H, A3 = A2 = L, A1 = H, A0 = L	(Note 4)	X	X
Temporary Sector Group Unprotect	X	X	X	V _{ID}	H	A _{IN}	(Note 4)	(Note 4)	High-Z

Legend

L = Logic Low = V_{IL}; H = Logic High = V_{IH}; V_{ID} = 8.5 V to 12.5 V; X = Don't Care; A_{IN} = Address In; D_{OUT} = Data Out

Notes

1. Address In = Amax:A0 in WORD mode (BYTE#=V_{IH}), Address In = Amax:A-1 in BYTE mode (BYTE#=V_{IL}). Sector addresses are Amax to A12 in both WORD mode and BYTE mode.
2. The sector group protect and sector group unprotect functions may also be implemented via programming equipment. See [Sector Group Protection/Unprotection on page 14](#).
3. If WP# = V_{IL}, the outermost sector remains protected (determined by device configuration). If WP# = V_{IH}, the outermost sector protection depends on whether the sector was last protected or unprotected using the method described in [Section 7.10, Sector Group Protection/Unprotection on page 14](#). The WP# contains an internal pull-up; when unconnected, WP is at V_{IH}.
4. D_{IN} or D_{OUT} as required by command sequence, data polling, or sector group protection algorithm.

7.1 Word/Byte Configuration

The BYTE# pin controls whether the device data I/O pins DQ15–DQ0 operate in the byte or word configuration. If the BYTE# pin is set at logic 1, the device is in word configuration, DQ15–DQ0 are active and controlled by CE# and OE#.

If the BYTE# pin is set at logic 0, the device is in byte configuration, and only data I/O pins DQ0–DQ7 are active and controlled by CE# and OE#. The data I/O pins DQ8–DQ14 are tristated, and the DQ15 pin is used as an input for the LSB (A-1) address function.

7.2 Requirements for Reading Array Data

To read array data from the outputs, the system must drive the CE# and OE# pins to V_{IL} . CE# is the power control and selects the device. OE# is the output control and gates array data to the output pins. WE# should remain at V_{IH} . The BYTE# pin determines whether the device outputs array data in words or bytes.

The internal state machine is set for reading array data upon device power-up, or after a hardware reset. This ensures that no spurious alteration of the memory content occurs during the power transition. No command is necessary in this mode to obtain array data. Standard microprocessor read cycles that assert valid addresses on the device address inputs produce valid data on the device data outputs. The device remains enabled for read access until the command register contents are altered.

See [Reading Array Data on page 22](#) for more information. Refer to the AC [Read Operations on page 36](#) for timing specifications and to [Figure 14 on page 36](#) for the timing diagram. I_{CC1} in [DC Characteristics on page 34](#) represents the active current specification for reading array data.

7.3 Writing Commands/Command Sequences

To write a command or command sequence (which includes programming data to the device and erasing sectors of memory), the system must drive WE# and CE# to V_{IL} , and OE# to V_{IH} .

For program operations, the BYTE# pin determines whether the device accepts program data in bytes or words. See [Word/Byte Configuration on page 10](#) for more information.

The device features an **Unlock Bypass** mode to facilitate faster programming. Once the device enters the Unlock Bypass mode, only two write cycles are required to program a word or byte, instead of four. [Word/Byte Program Command Sequence on page 23](#) has details on programming data to the device using both standard and Unlock Bypass command sequences.

An erase operation can erase one sector, multiple sectors, or the entire device. [Table 2 on page 11](#) and [Table 4 on page 12](#) indicate the address space that each sector occupies. A “sector address” consists of the address bits required to uniquely select a sector. The [Command Definitions on page 22](#) has details on erasing a sector or the entire chip, or suspending/resuming the erase operation.

After the system writes the autoselect command sequence, the device enters the autoselect mode. The system can then read autoselect codes from the internal register (which is separate from the memory array) on DQ7–DQ0. Standard read cycle timings apply in this mode. Refer to [Autoselect Mode on page 13](#) and [Autoselect Command Sequence on page 22](#) for more information.

I_{CC2} in [DC Characteristics on page 34](#) represents the active current specification for the write mode. [AC Characteristics on page 36](#) contains timing specification tables and timing diagrams for write operations.

7.4 Program and Erase Operation Status

During an erase or program operation, the system may check the status of the operation by reading the status bits on DQ7–DQ0. Standard read cycle timings and I_{CC} read specifications apply. Refer to [Write Operation Status on page 28](#) for more information, and to [AC Characteristics on page 36](#) for timing diagrams.

7.5 Standby Mode

When the system is not reading or writing to the device, it can place the device in the standby mode. In this mode, current consumption is greatly reduced, and the outputs are placed in the high impedance state, independent of the OE# input.

The device enters the CMOS standby mode when the CE# and RESET# pins are both held at $V_{CC} \pm 0.3$ V. (Note that this is a more restricted voltage range than V_{IH} .) If CE# and RESET# are held at V_{IH} , but not within $V_{CC} \pm 0.3$ V, the device will be in the standby mode, but the standby current will be greater. The device requires standard access time (t_{CE}) for read access when the device is in either of these standby modes, before it is ready to read data.

If the device is deselected during erasure or programming, the device draws active current until the operation is completed.

I_{CC3} and I_{CC4} represents the standby current specification shown in the table in [DC Characteristics on page 34](#).

7.6 Automatic Sleep Mode

The automatic sleep mode minimizes Flash device energy consumption. The device automatically enables this mode when addresses remain stable for $t_{ACC} + 30$ ns. The automatic sleep mode is independent of the CE#, WE#, and OE# control signals. Standard address access timings provide new data when addresses are changed. While in sleep mode, output data is latched and always available to the system. I_{CC4} in the [DC Characteristics on page 34](#) represents the automatic sleep mode current specification.

7.7 RESET#: Hardware Reset Pin

The RESET# pin provides a hardware method of resetting the device to reading array data. When the system drives the RESET# pin to V_{IL} for at least a period of t_{RP} , the device **immediately terminates** any operation in progress, tristates all data output pins, and ignores all read/write attempts for the duration of the RESET# pulse. The device also resets the internal state machine to reading array data. The operation that was interrupted should be reinitiated once the device is ready to accept another command sequence, to ensure data integrity.

Current is reduced for the duration of the RESET# pulse. When RESET# is held at $V_{SS} \pm 0.3$ V, the device draws CMOS standby current (I_{CC4}). If RESET# is held at V_{IL} but not within $V_{SS} \pm 0.3/0.1$ V, the standby current will be greater.

The RESET# pin may be tied to the system reset circuitry. A system reset would thus also reset the Flash memory, enabling the system to read the boot-up firmware from the Flash memory. Note that the CE# pin should only go to V_{IL} after RESET# has gone to V_{IH} . Keeping CE# at V_{IL} from power up through the first read could cause the first read to retrieve erroneous data.

If RESET# is asserted during a program or erase operation, the RY/BY# pin remains a 0 (busy) until the internal reset operation is complete, which requires a time of t_{READY} (during Embedded Algorithms). The system can thus monitor RY/BY# to determine whether the reset operation is complete. If RESET# is asserted when a program or erase operation is not executing (RY/BY# pin is 1), the reset operation is completed within a time of t_{READY} (not during Embedded Algorithms). The system can read data t_{RH} after the RESET# pin returns to V_{IH} .

Refer to the tables in [AC Characteristics on page 36](#) for RESET# parameters and to [Figure 15 on page 37](#) for the timing diagram.

7.8 Output Disable Mode

When the OE# input is at V_{IH} , output from the device is disabled. The output pins are placed in the high impedance state.

Table 2. S29AL008J Top Boot Block Sector Addresses

Sector	A18	A17	A16	A15	A14	A13	A12	Sector Size (Kbytes/ Kwords)	Address Range (in hexadecimal)	
									(x8) Address Range	(x16) Address Range
SA0	0	0	0	0	X	X	X	64/32	00000h–0FFFFh	00000h–07FFFh
SA1	0	0	0	1	X	X	X	64/32	10000h–1FFFFh	08000h–0FFFFh
SA2	0	0	1	0	X	X	X	64/32	20000h–2FFFFh	10000h–17FFFh
SA3	0	0	1	1	X	X	X	64/32	30000h–3FFFFh	18000h–1FFFFh
SA4	0	1	0	0	X	X	X	64/32	40000h–4FFFFh	20000h–27FFFh
SA5	0	1	0	1	X	X	X	64/32	50000h–5FFFFh	28000h–2FFFFh
SA6	0	1	1	0	X	X	X	64/32	60000h–6FFFFh	30000h–37FFFh
SA7	0	1	1	1	X	X	X	64/32	70000h–7FFFFh	38000h–3FFFFh
SA8	1	0	0	0	X	X	X	64/32	80000h–8FFFFh	40000h–47FFFh
SA9	1	0	0	1	X	X	X	64/32	90000h–9FFFFh	48000h–4FFFFh
SA10	1	0	1	0	X	X	X	64/32	A0000h–AFFFFh	50000h–57FFFh
SA11	1	0	1	1	X	X	X	64/32	B0000h–BFFFFh	58000h–5FFFFh
SA12	1	1	0	0	X	X	X	64/32	C0000h–CFFFFh	60000h–67FFFh
SA13	1	1	0	1	X	X	X	64/32	D0000h–DFFFFh	68000h–6FFFFh
SA14	1	1	1	0	X	X	X	64/32	E0000h–EFFFFh	70000h–77FFFh

Table 2. S29AL008J Top Boot Block Sector Addresses (Continued)

Sector	A18	A17	A16	A15	A14	A13	A12	Sector Size (Kbytes/ Kwords)	Address Range (in hexadecimal)	
									(x8) Address Range	(x16) Address Range
SA15	1	1	1	1	0	X	X	32/16	F0000h–F7FFFh	78000h–7BFFFh
SA16	1	1	1	1	1	0	0	8/4	F8000h–F9FFFh	7C000h–7CFFFh
SA17	1	1	1	1	1	0	1	8/4	FA000h–FBFFFh	7D000h–7DFFFh
SA18	1	1	1	1	1	1	X	16/8	FC000h–FFFFFh	7E000h–7FFFFh

Note

Address range is A18:A-1 in byte mode and A19:A0 in word mode. See [Word/Byte Configuration on page 10](#).

Table 3. Secured Silicon Sector Addresses (Top Boot)

Sector Size (bytes/words)	x8 Address Range	x16 Address Range
256/128	FFF00h–FFFFFh	7FF80h–7FFFFh

Table 4. S29AL008J Bottom Boot Block Sector Addresses

Sector	A18	A17	A16	A15	A14	A13	A12	Sector Size (Kbytes/ Kwords)	Address Range (in hexadecimal)	
									(x8) Address Range	(x16) Address Range
SA0	0	0	0	0	0	0	X	16/8	00000h–03FFFh	00000h–01FFFh
SA1	0	0	0	0	0	1	0	8/4	04000h–05FFFh	02000h–02FFFh
SA2	0	0	0	0	0	1	1	8/4	06000h–07FFFh	03000h–03FFFh
SA3	0	0	0	0	1	X	X	32/16	08000h–0FFFFh	04000h–07FFFh
SA4	0	0	0	1	X	X	X	64/32	10000h–1FFFFh	08000h–0FFFFh
SA5	0	0	1	0	X	X	X	64/32	20000h–2FFFFh	10000h–17FFFh
SA6	0	0	1	1	X	X	X	64/32	30000h–3FFFFh	18000h–1FFFFh
SA7	0	1	0	0	X	X	X	64/32	40000h–4FFFFh	20000h–27FFFh
SA8	0	1	0	1	X	X	X	64/32	50000h–5FFFFh	28000h–2FFFFh
SA9	0	1	1	0	X	X	X	64/32	60000h–6FFFFh	30000h–37FFFh
SA10	0	1	1	1	X	X	X	64/32	70000h–7FFFFh	38000h–3FFFFh
SA11	1	0	0	0	X	X	X	64/32	80000h–8FFFFh	40000h–47FFFh
SA12	1	0	0	1	X	X	X	64/32	90000h–9FFFFh	48000h–4FFFFh
SA13	1	0	1	0	X	X	X	64/32	A0000h–AFFFFh	50000h–57FFFh
SA14	1	0	1	1	X	X	X	64/32	B0000h–BFFFFh	58000h–5FFFFh
SA15	1	1	0	0	X	X	X	64/32	C0000h–CFFFFh	60000h–67FFFh
SA16	1	1	0	1	X	X	X	64/32	D0000h–DFFFFh	68000h–6FFFFh
SA17	1	1	1	0	X	X	X	64/32	E0000h–EFFFFh	70000h–77FFFh
SA18	1	1	1	1	X	X	X	64/32	F0000h–FFFFFh	78000h–7FFFFh

Note

Address range is A18:A-1 in byte mode and A19:A0 in word mode. See the [Word/Byte Configuration on page 10](#).

Table 5. Secured Silicon Sector Addresses (Bottom Boot)

Sector Size (bytes/words)	x8 Address Range	x16 Address Range
256/128	000000h–0000FFh	00000h–0007Fh

7.9 Autoselect Mode

The autoselect mode provides manufacturer and device identification, and sector group protection verification, through identifier codes output on DQ7–DQ0. This mode is primarily intended for programming equipment to automatically match a device to be programmed with its corresponding programming algorithm. However, the autoselect codes can also be accessed in-system through the command register.

When using programming equipment, the autoselect mode requires V_{ID} (8.5 V to 12.5 V) on address pin A9. Address pins A6 and A3–A0 must be as shown in Table 6. In addition, when verifying sector group protection, the sector address must appear on the appropriate highest order address bits (see Table 2 on page 11 and Table 4 on page 12). Table 6 shows the remaining address bits that are don't care. When all necessary bits have been set as required, the programming equipment may then read the corresponding identifier code on DQ7–DQ0.

To access the autoselect codes in-system, the host system can issue the autoselect command via the command register, as shown in Table 13 on page 26. This method does not require V_{ID} . See Command Definitions on page 22 for details on using the autoselect mode.

Table 6. S29AL008J Autoselect Codes (High Voltage Method)

Description	Mode	CE#	OE#	WE#	A18 to A10	A9	A8 to A7	A6	A5 to A4	A3 to A2	A1	A0	DQ8 to DQ15	DQ7 to DQ0
Manufacturer ID: Cypress		L	L	H	X	V_{ID}	X	L	X	L	L	L	X	01h
Device ID: S29AL008J (Top Boot Block)	Word	L	L	H	X	V_{ID}	X	L	X	L	L	H	22h	DAh
	Byte	L	L	H	X	V_{ID}	X	L	X	L	L	H	X	DAh
Device ID: S29AL008J (Bottom Boot Block)	Word	L	L	H	X	V_{ID}	X	L	X	L	L	H	22h	5Bh
	Byte	L	L	H	X	V_{ID}	X	L	X	L	L	H	X	5Bh
Sector Group Protection Verification		L	L	H	SA	V_{ID}	X	L	X	L	H	L	X	01h (protected)
													X	00h (unprotected)
Secured Silicon Sector Indicator Bit (DQ7) Top Boot Block		L	L	H	X	V_{ID}	X	L	X	L	H	H	X	8Eh (factory locked) 0Eh (not factory locked)
Secured Silicon Sector Indicator Bit (DQ7) Bottom Boot Block		L	L	H	X	V_{ID}	X	L	X	L	H	H	X	96h (factory locked) 16h (not factory locked)

Legend

L = Logic Low = V_{IL} ; H = Logic High = V_{IH} ; SA = Sector Address; X = Don't care

Note

The autoselect codes may also be accessed in-system via command sequences. See Table 13 on page 26.

7.10 Sector Group Protection/Unprotection

The hardware sector group protection feature disables both program and erase operations in any sector group (see [Table 2 on page 11](#) to [Table 5 on page 12](#)). The hardware sector group unprotection feature re-enables both program and erase operations in previously protected sector groups. Sector group protection/unprotection can be implemented via two methods.

Sector protection/unprotection requires V_{ID} on the RESET# pin only, and can be implemented either in-system or via programming equipment. [Figure 4 on page 16](#) shows the algorithms and [Figure 24 on page 42](#) shows the timing diagram. This method uses standard microprocessor bus cycle timing. For sector group unprotect, all unprotected sector groups must first be protected prior to the first sector group unprotect write cycle.

The device is shipped with all sector groups unprotected. Cypress offers the option of programming and protecting sector groups at its factory prior to shipping the device through Cypress Programming Service. Contact a Cypress representative for details.

It is possible to determine whether a sector group is protected or unprotected. See [Autoselect Mode on page 13](#) for details.

Table 7. S29AL008J Top Boot Device Sector/Sector Group Protection

Sector / Sector Block	A18	A17	A16	A15	A14	A13	A12	Sector / Sector Block Size
SA0-SA3	0	0	X	X	X	X	X	256 (4x64) Kbytes
SA4-SA7	0	1	X	X	X	X	X	256 (4x64) Kbytes
SA8-SA11	1	0	X	X	X	X	X	256 (4x64) Kbytes
SA12-SA13	1	1	0	X	X	X	X	128 (2x64) Kbytes
SA14	1	1	1	0	X	X	X	64 Kbytes
SA15	1	1	1	1	0	X	X	32 Kbytes
SA16	1	1	1	1	1	0	0	8 Kbytes
SA17	1	1	1	1	1	0	1	8 Kbytes
SA18	1	1	1	1	1	1	X	16 Kbytes

Table 8. S29AL008J Bottom Boot Device Sector/Sector Group Protection

Sector / Sector Block	A18	A17	A16	A15	A14	A13	A12	Sector / Sector Block Size
SA0	0	0	0	0	0	0	X	16 Kbytes
SA1	0	0	0	0	0	1	0	8 Kbytes
SA2	0	0	0	0	0	1	1	8 Kbytes
SA3	0	0	0	0	1	X	X	32 Kbytes
SA4	0	0	0	1	X	X	X	64 Kbytes
SA5-SA6	0	0	1	X	X	X	X	128 (2x64) Kbytes
SA7-SA10	0	1	X	X	X	X	X	256 (4x64) Kbytes
SA11-SA14	1	0	X	X	X	X	X	256 (4x64) Kbytes
SA15-SA18	1	1	X	X	X	X	X	256 (4x64) Kbytes

7.11 Temporary Sector Group Unprotect

This feature allows temporary unprotection of previously protected sector groups to change data in-system. The Sector Group Unprotect mode is activated by setting the RESET# pin to V_{ID} . During this mode, formerly protected sector groups can be programmed or erased by selecting the sector addresses. Once V_{ID} is removed from the RESET# pin, all the previously protected sector groups are protected again. Figure 3 shows the algorithm, and Figure 24 on page 42 shows the timing diagrams, for this feature.

Figure 3. Temporary Sector Group Unprotect Operation



Notes

1. All protected sector groups unprotected. (If WP# = V_{IL} , the highest or lowest address sector remains protected for uniform sector devices; the top or bottom two address sectors remains protected for boot sector devices).
2. All previously protected sector groups are protected once again.

Figure 4. In-System Sector Group Protect/Unprotect Algorithms

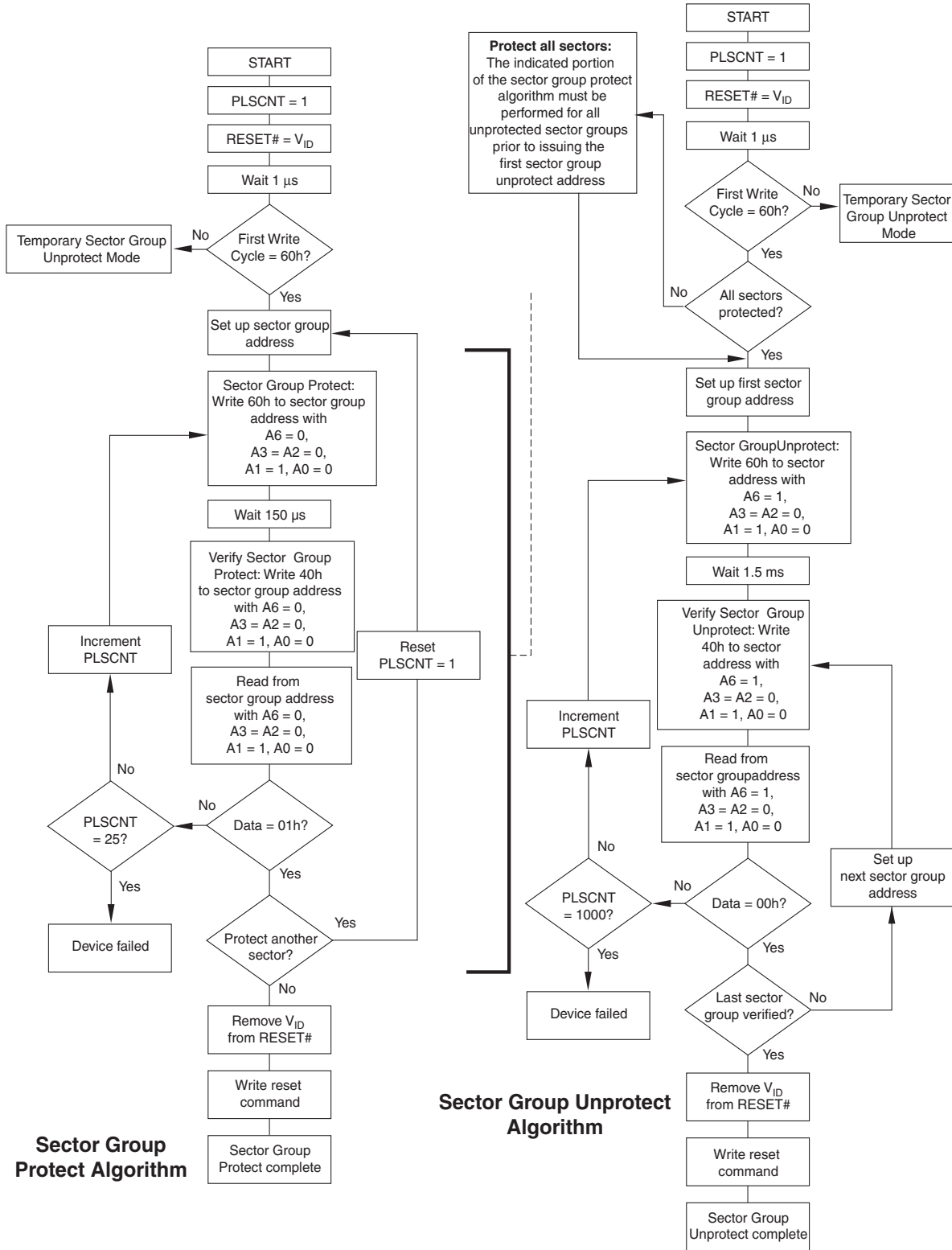

8. Secured Silicon Sector Flash Memory Region

The Secured Silicon Sector feature provides a 256-byte Flash memory region that enables permanent part identification through an Electronic Serial Number (ESN). The Secured Silicon Sector uses a Secured Silicon Sector Indicator Bit (DQ7) to indicate whether or not the Secured Silicon Sector is locked when shipped from the factory. This bit is permanently set at the factory and cannot be changed, which prevents cloning of a factory-locked part. This ensures the security of the ESN once the product is shipped to the field.

Cypress offers the device with the Secured Silicon Sector either factory-locked or customer-lockable. The factory-locked version is always protected when shipped from the factory, and has the Secured Silicon Sector Indicator Bit permanently set to a 1. The customer-lockable version is shipped with the Secured Silicon Sector unprotected, allowing customers to utilize the that sector in any manner they choose. The customer-lockable version has the Secured Silicon Sector Indicator Bit permanently set to a 0. Thus, the Secured Silicon Sector Indicator Bit prevents customer-lockable devices from being used to replace devices that are factory locked.

The system accesses the Secured Silicon Sector through a command sequence (see “[Enter Secured Silicon Sector/Exit Secured Silicon Sector Command Sequence](#)” on page 23). After the system writes the Enter Secured Silicon Sector command sequence, it may read the Secured Silicon Sector by using the addresses normally occupied by the boot sectors. This mode of operation continues until the system issues the Exit Secured Silicon Sector command sequence, or until power is removed from the device. On power-up, or following a hardware reset, the device reverts to sending commands to the boot sectors.

8.1 Factory Locked: Secured Silicon Sector Programmed and Protected at the Factory

In a factory locked device, the Secured Silicon Sector is protected when the device is shipped from the factory. The Secured Silicon Sector cannot be modified in any way. The device is available pre-programmed with one of the following:

- A random, secure ESN only.
- Customer code through the ExpressFlash service.
- Both a random, secure ESN and customer code through the ExpressFlash service.

In devices that have an ESN, a Bottom Boot device has the 16-byte (8-word) ESN in sector 0 at addresses 00000h–0000Fh in byte mode (or 00000h–00007h in word mode). In the Top Boot device, the ESN is in sector 18 at addresses FFFF0h–FFFFFh in byte mode (or 7FFF8h–7FFFFh in word mode).

Customers may opt to have their code programmed by Cypress through the Cypress ExpressFlash service. Cypress programs the customer’s code, with or without the random ESN. The devices are then shipped from the Cypress factory with the Secured Silicon Sector permanently locked. Contact a Cypress representative for details on using the Cypress ExpressFlash service.

8.2 Customer Lockable: Secured Silicon Sector NOT Programmed or Protected at the Factory

The customer lockable version allows the Secured Silicon Sector to be programmed once, and then permanently locked after it ships from Cypress. Note that the unlock bypass functions is not available when programming the Secured Silicon Sector.

The Secured Silicon Sector area can be protected using the following procedures:

- Write the three-cycle Enter Secured Silicon Region command sequence, and then follow the in-system sector group protect algorithm as shown in [Figure 4 on page 16](#), substituting the sector group address with the Secured Silicon Sector group address (A0=0, A1=1, A2=0, A3=1, A4=1, A5=0, A6=0, A7=0). Note that this method is only applicable to the Secured Silicon Sector.
- To verify the protect/unprotect status of the Secured Silicon Sector, follow the algorithm shown in [Figure 5 on page 18](#).

Once the Secured Silicon Sector is locked and verified, the system must write the Exit Secured Silicon Sector Region command sequence to return to reading and writing the remainder of the array.

The Secured Silicon Sector protection must be used with caution since, once protected, there is no procedure available for unprotecting the Secured Silicon Sector area, and none of the bits in the Secured Silicon Sector memory space can be modified in any way.

Figure 5. Secured Silicon Sector Protect Verify

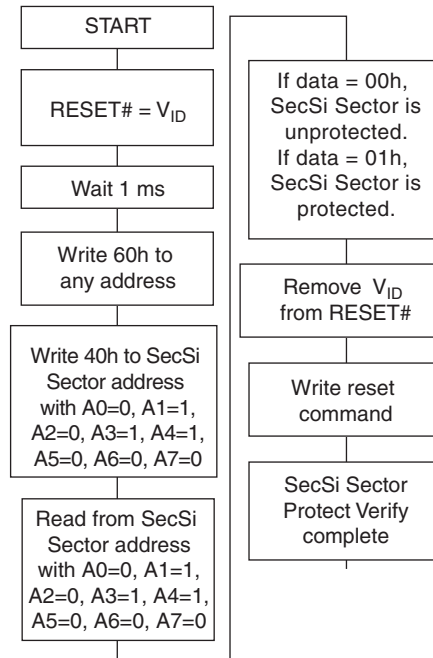

9. Common Flash Memory Interface (CFI)

The Common Flash Interface (CFI) specification outlines device and host system software interrogation handshake, which allows specific vendor-specified software algorithms to be used for entire families of devices. Software support can then be device-independent, JEDEC ID-independent, and forward- and backward-compatible for the specified flash device families. Flash vendors can standardize their existing interfaces for long-term compatibility.

This device enters the CFI Query mode when the system writes the CFI Query command, 98h, to address 55h in word mode (or address AAh in byte mode), any time the device is ready to read array data. The system can read CFI information at the addresses given in [Table 9](#) to [Table 12](#) on [page 20](#). In word mode, the upper address bits (A7–MSB) must be all zeros. To terminate reading CFI data, the system must write the reset command.

The system can also write the CFI query command when the device is in the autoselect mode. The device enters the CFI query mode, and the system can read CFI data at the addresses given in the following tables. The system must write the reset command to return the device to the autoselect mode.

Table 9. CFI Query Identification String

Addresses (Word Mode)	Addresses (Byte Mode)	Data	Description
10h 11h 12h	20h 22h 24h	0051h 0052h 0059h	Query Unique ASCII string "QRY"
13h 14h	26h 28h	0002h 0000h	Primary OEM Command Set
15h 16h	2Ah 2Ch	0040h 0000h	Address for Primary Extended Table
17h 18h	2Eh 30h	0000h 0000h	Alternate OEM Command Set (00h = none exists)
19h 1Ah	32h 34h	0000h 0000h	Address for Alternate OEM Extended Table (00h = none exists)

Table 10. System Interface String

Addresses (Word Mode)	Addresses (Byte Mode)	Data	Description
1Bh	36h	0027h	V _{CC} Min. (write/erase) D7–D4: volt, D3–D0: 100 millivolt
1Ch	38h	0036h	V _{CC} Max. (write/erase) D7–D4: volt, D3–D0: 100 millivolt
1Dh	3Ah	0000h	V _{PP} Min. voltage (00h = no V _{PP} pin present)
1Eh	3Ch	0000h	V _{PP} Max. voltage (00h = no V _{PP} pin present)
1Fh	3Eh	0003h	Typical timeout per single byte/word write 2 ^N μs
20h	40h	0000h	Typical timeout for Min. size buffer write 2 ^N μs (00h = not supported)
21h	42h	0009h	Typical timeout per individual block erase 2 ^N ms
22h	44h	0000h	Typical timeout for full chip erase 2 ^N ms (00h = not supported)
23h	46h	0005h	Max. timeout for byte/word write 2 ^N times typical
24h	48h	0000h	Max. timeout for buffer write 2 ^N times typical
25h	4Ah	0004h	Max. timeout per individual block erase 2 ^N times typical
26h	4Ch	0000h	Max. timeout for full chip erase 2 ^N times typical (00h = not supported)

Table 11. Device Geometry Definition

Addresses (Word Mode)	Addresses (Byte Mode)	Data	Description
27h	4Eh	0014h	Device Size = 2 ^N byte
28h 29h	50h 52h	0002h 0000h	Flash Device Interface description (refer to CFI publication 100)
2Ah 2Bh	54h 56h	0000h 0000h	Max. number of byte in multi-byte write = 2 ^N (00h = not supported)
2Ch	58h	0004h	Number of Erase Block Regions within device
2Dh 2Eh 2Fh 30h	5Ah 5Ch 5Eh 60h	0000h 0000h 0040h 0000h	Erase Block Region 1 Information (refer to the CFI specification or CFI publication 100)
31h 32h 33h 34h	62h 64h 66h 68h	0001h 0000h 0020h 0000h	Erase Block Region 2 Information
35h 36h 37h 38h	6Ah 6Ch 6Eh 70h	0000h 0000h 0080h 0000h	Erase Block Region 3 Information
39h 3Ah 3Bh 3Ch	72h 74h 76h 78h	000Eh 0000h 0000h 0001h	Erase Block Region 4 Information

Table 12. Primary Vendor-Specific Extended Query

Addresses (Word Mode)	Addresses (Byte Mode)	Data	Description
40h 41h 42h	80h 82h 84h	0050h 0052h 0049h	Query-unique ASCII string "PRI"
43h	86h	0031h	Major version number, ASCII
44h	88h	0033h	Minor version number, ASCII
45h	8Ah	000Ch	Address Sensitive Unlock 0 = Required, 1 = Not Required Process Technology (Bits 5-2) 0011b = 0.11 μm Floating Gate NOR
46h	8Ch	0002h	Erase Suspend 0 = Not Supported, 1 = To Read Only, 2 = To Read & Write
47h	8Eh	0001h	Sector Group Protect 0 = Not Supported, X= Number of sectors in smallest sector group
48h	90h	0001h	Sector Group Temporary Unprotect 00 = Not Supported, 01 = Supported
49h	92h	0004h	Sector Group Protect/Unprotect scheme 01 = 29F040 mode, 02 = 29F016 mode, 03 = 29F400 mode, 04 = 29LV800A mode
4Ah	94h	0000h	Simultaneous Operation 00 = Not Supported, 01 = Supported

Table 12. Primary Vendor-Specific Extended Query (Continued)

Addresses (Word Mode)	Addresses (Byte Mode)	Data	Description
4Bh	96h	0000h	Burst Mode Type 00 = Not Supported, 01 = Supported
4Ch	98h	0000h	Page Mode Type 00 = Not Supported, 01 = 4 Word Page, 02 = 8 Word Page
4Dh	9Ah	0000h	ACC (Acceleration) Supply Minimum 00 = Not Supported, D7-D4: Volt, D3-D0: 100mV
4Eh	9Ch	0000h	ACC (Acceleration) Supply Maximum 00 = Not Supported, D7-D4: Volt, D3-D0: 100mV
4Fh	9Eh	00XXh	WP# Protection 00 = Uniform Device without WP Protect 01 = Boot Device with TOP and Bottom WP Protect 02 = Bottom Boot Device with WP Protect 03 = Top Boot Device with WP Protect 04 = Uniform Device with Bottom WP Protect 05 = Uniform Device with Top WP Protect 06 = Uniform Device with All Sectors WP Protect
50h	A0h	00XXh	Program Suspend 00 = Not Supported, 01 = Supported

9.1 Hardware Data Protection

The command sequence requirement of unlock cycles for programming or erasing provides data protection against inadvertent writes (refer to [13S29AL008J Command Definitions on page 26](#) for command definitions). In addition, the following hardware data protection measures prevent accidental erasure or programming, which might otherwise be caused by spurious system level signals during V_{CC} power-up and power-down transitions, or from system noise.

9.1.1 Low V_{CC} Write Inhibit

When V_{CC} is less than V_{LKO} , the device does not accept any write cycles. This protects data during V_{CC} power-up and power-down. The command register and all internal program/erase circuits are disabled, and the device resets. Subsequent writes are ignored until V_{CC} is greater than V_{LKO} . The system must provide the proper signals to the control pins to prevent unintentional writes when V_{CC} is greater than V_{LKO} .

9.1.2 Write Pulse Glitch Protection

Noise pulses of less than 5 ns (typical) on OE#, CE# or WE# do not initiate a write cycle.

9.1.3 Logical Inhibit

Write cycles are inhibited by holding any one of OE# = V_{IL} , CE# = V_{IH} or WE# = V_{IH} . To initiate a write cycle, CE# and WE# must be a logical zero while OE# is a logical one.

9.1.4 Power-Up Write Inhibit

If WE# = CE# = V_{IL} and OE# = V_{IH} during power up, the device does not accept commands on the rising edge of WE#. The internal state machine is automatically reset to reading array data on power-up.

10. Command Definitions

Writing specific address and data commands or sequences into the command register initiates device operations. [Table 13 on page 26](#) defines the valid register command sequences. Writing **incorrect address and data values** or writing them in the **improper sequence** resets the device to reading array data.

All addresses are latched on the falling edge of WE# or CE#, whichever happens later. All data is latched on the rising edge of WE# or CE#, whichever happens first. Refer to the appropriate timing diagrams in [AC Characteristics on page 36](#).

10.1 Reading Array Data

The device is automatically set to reading array data after device power-up. No commands are required to retrieve data. The device is also ready to read array data after completing an Embedded Program or Embedded Erase algorithm.

After the device accepts an Erase Suspend command, the device enters the Erase Suspend mode. The system can read array data using the standard read timings, except that if it reads at an address within erase-suspended sectors, the device outputs status data. After completing a programming operation in the Erase Suspend mode, the system may once again read array data with the same exception. See [Erase Suspend/Erase Resume Commands on page 25](#) for more information on this mode.

The system *must* issue the reset command to re-enable the device for reading array data if DQ5 goes high, or while in the autoselect mode. See [Reset Command on page 22](#).

See also [Requirements for Reading Array Data on page 10](#) for more information. The [Read Operations on page 36](#) provides the read parameters, and [Figure 14 on page 36](#) shows the timing diagram.

10.2 Reset Command

Writing the reset command to the device resets the device to reading array data. Address bits are don't care for this command.

The reset command may be written between the sequence cycles in an erase command sequence before erasing begins. This resets the device to reading array data. Once erasure begins, however, the device ignores reset commands until the operation is complete.

The reset command may be written between the sequence cycles in a program command sequence before programming begins. This resets the device to reading array data (also applies to programming in Erase Suspend mode). Once programming begins, however, the device ignores reset commands until the operation is complete.

The reset command may be written between the sequence cycles in an autoselect command sequence. Once in the autoselect mode, the reset command *must* be written to return to reading array data (also applies to autoselect during Erase Suspend).

If DQ5 goes high during a program or erase operation, writing the reset command returns the device to reading array data (also applies during Erase Suspend).

10.3 Autoselect Command Sequence

The autoselect command sequence allows the host system to access the manufacturer and devices codes, and determine whether or not a sector is protected. [Table 13 on page 26](#) shows the address and data requirements. This method is an alternative to that shown in [Table 6 on page 13](#), which is intended for PROM programmers and requires V_{ID} on address bit A9.

The autoselect command sequence is initiated by writing two unlock cycles, followed by the autoselect command. The device then enters the autoselect mode, and the system may read at any address any number of times, without initiating another command sequence.

A read cycle at address XX00h retrieves the manufacturer code. A read cycle at address XX01h returns the device code. A read cycle containing a sector address (SA) and the address 02h in word mode (or 04h in byte mode) returns 01h if that sector is protected, or 00h if it is unprotected. Refer to [Table 2 on page 11](#) and [Table 4 on page 12](#) for valid sector addresses.

The system must write the reset command to exit the autoselect mode and return to reading array data.

10.4 Enter Secured Silicon Sector/Exit Secured Silicon Sector Command Sequence

The Secured Silicon Sector region provides a secured data area containing a random, sixteen-byte electronic serial number (ESN). The system can access the Secured Silicon Sector region by issuing the three-cycle Enter Secured Silicon Sector command sequence. The device continues to access the Secured Silicon Sector region until the system issues the four-cycle Exit Secured Silicon Sector command sequence. The Exit Secured Silicon Sector command sequence returns the device to normal operation. [13S29AL008J Command Definitions on page 26](#) shows the addresses and data requirements for both command sequences. Note that the unlock bypass mode is not available when the device enters the Secured Silicon Sector. See also “[Secured Silicon Sector Flash Memory Region](#)” on page 17 for further information.

10.5 Word/Byte Program Command Sequence

The system may program the device by word or byte, depending on the state of the BYTE# pin. Programming is a four-bus-cycle operation. The program command sequence is initiated by writing two unlock write cycles, followed by the program set-up command. The program address and data are written next, which in turn initiate the Embedded Program algorithm. The system is *not* required to provide further controls or timings. The device automatically generates the program pulses and verifies the programmed cell margin. [Table 13 on page 26](#) shows the address and data requirements for the byte program command sequence.

When the Embedded Program algorithm is complete, the device then returns to reading array data and addresses are no longer latched. The system can determine the status of the program operation by using DQ7, DQ6, or RY/BY#. See [Write Operation Status on page 28](#) for information on these status bits.

Any commands written to the device during the Embedded Program Algorithm are ignored. Note that a **hardware reset** immediately terminates the programming operation. The Byte Program command sequence should be reinitiated once the device has reset to reading array data, to ensure data integrity.

Programming is allowed in any sequence and across sector boundaries. **A bit cannot be programmed from a 0 back to a 1.** Attempting to do so may halt the operation and set DQ5 to 1, or cause the Data# Polling algorithm to indicate the operation was successful. However, a succeeding read will show that the data is still 0. Only erase operations can convert a 0 to a 1.

10.6 Unlock Bypass Command Sequence

The unlock bypass feature allows the system to program bytes or words to the device faster than using the standard program command sequence. The unlock bypass command sequence is initiated by first writing two unlock cycles. This is followed by a third write cycle containing the unlock bypass command, 20h. The device then enters the unlock bypass mode. A two-cycle unlock bypass program command sequence is all that is required to program in this mode. The first cycle in this sequence contains the unlock bypass program command, A0h; the second cycle contains the program address and data. Additional data is programmed in the same manner. This mode dispenses with the initial two unlock cycles required in the standard program command sequence, resulting in faster total programming time. [Table 13 on page 26](#) shows the requirements for the command sequence.

During the unlock bypass mode, only the Unlock Bypass Program and Unlock Bypass Reset commands are valid. To exit the unlock bypass mode, the system must issue the two-cycle unlock bypass reset command sequence. The first cycle must contain the data 90h; the second cycle the data 00h. Addresses are don't care for both cycles. The device then returns to reading array data.

[Figure 6 on page 24](#) illustrates the algorithm for the program operation. See [Erase/Program Operations on page 39](#) for parameters, and to [Figure 18 on page 39](#) for timing diagrams.

Figure 6. Program Operation

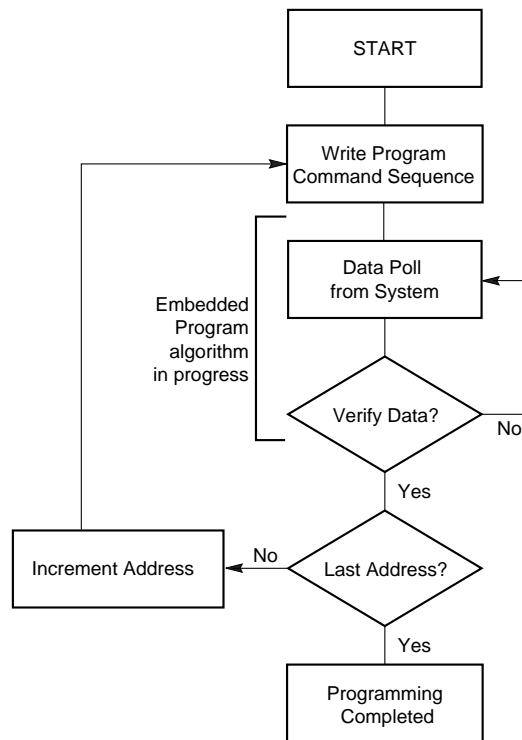

Note
See [Table 13 on page 26](#) for program command sequence.

10.7 Chip Erase Command Sequence

Chip erase is a six bus cycle operation. The chip erase command sequence is initiated by writing two unlock cycles, followed by a set-up command. Two additional unlock write cycles are then followed by the chip erase command, which in turn invokes the Embedded Erase algorithm. The device does *not* require the system to preprogram prior to erase. The Embedded Erase algorithm automatically preprograms and verifies the entire memory for an all zero data pattern prior to electrical erase. The system is not required to provide any controls or timings during these operations. [Table 13 on page 26](#) shows the address and data requirements for the chip erase command sequence.

Any commands written to the chip during the Embedded Erase algorithm are ignored. Note that a **hardware reset** during the chip erase operation immediately terminates the operation. The Chip Erase command sequence should be reinitiated once the device has returned to reading array data, to ensure data integrity.

The system can determine the status of the erase operation by using DQ7, DQ6, DQ2, or RY/BY#. See [Write Operation Status on page 28](#) for information on these status bits. When the Embedded Erase algorithm is complete, the device returns to reading array data and addresses are no longer latched.

[Figure 7 on page 26](#) illustrates the algorithm for the erase operation. See [Erase/Program Operations on page 39](#) for parameters, and [Figure 19 on page 40](#) for timing diagrams.

10.8 Sector Erase Command Sequence

Sector erase is a six bus cycle operation. The sector erase command sequence is initiated by writing two unlock cycles, followed by a set-up command. Two additional unlock write cycles are then followed by the address of the sector to be erased, and the sector erase command. [Table 13 on page 26](#) shows the address and data requirements for the sector erase command sequence.

The device does *not* require the system to preprogram the memory prior to erase. The Embedded Erase algorithm automatically programs and verifies the sector for an all zero data pattern prior to electrical erase. The system is not required to provide any controls or timings during these operations.

After the command sequence is written, a sector erase time-out of 50 μ s begins. During the time-out period, additional sector addresses and sector erase commands may be written. However, these additional erase commands are only one bus cycle long and should be identical to the sixth cycle of the standard erase command explained above. Loading the sector erase buffer may be done in any sequence, and the number of sectors may be from one sector to all sectors. The time between these additional cycles must be less than 50 μ s, otherwise the last address and command might not be accepted, and erasure may begin. It is recommended that processor interrupts be disabled during this time to ensure all commands are accepted. The interrupts can be re-enabled after the last Sector Erase command is written. If the time between additional sector erase commands can be assumed to be less than 50 μ s, the system need not monitor DQ3. **Any command other than Sector Erase or Erase Suspend during the time-out period resets the device to reading array data.** The system must rewrite the command sequence and any additional sector addresses and commands.

The system can monitor DQ3 to determine if the sector erase timer has timed out. (See [DQ3: Sector Erase Timer on page 31](#).) The time-out begins from the rising edge of the final WE# pulse in the command sequence.

Once the sector erase operation has begun, only the Erase Suspend command is valid. All other commands are ignored. Note that a **hardware reset** during the sector erase operation immediately terminates the operation. The Sector Erase command sequence should be reinitiated once the device has returned to reading array data, to ensure data integrity.

When the Embedded Erase algorithm is complete, the device returns to reading array data and addresses are no longer latched. The system can determine the status of the erase operation by using DQ7, DQ6, DQ2, or RY/BY#. (Refer to [Write Operation Status on page 28](#) for information on these status bits.)

[Figure 7 on page 26](#) illustrates the algorithm for the erase operation. Refer to [Erase/Program Operations on page 39](#) for parameters, and to [Figure 19 on page 40](#) for timing diagrams.

10.9 Erase Suspend/Erase Resume Commands

The Erase Suspend command allows the system to interrupt a sector erase operation and then read data from, or program data to, any sector not selected for erasure. This command is valid only during the sector erase operation, including the 50 μ s time-out period during the sector erase command sequence. The Erase Suspend command is ignored if written during the chip erase operation or Embedded Program algorithm. Writing the Erase Suspend command during the Sector Erase time-out immediately terminates the time-out period and suspends the erase operation. Addresses are *don't-cares* when writing the Erase Suspend command.

When the Erase Suspend command is written during a sector erase operation, the device requires a maximum of 35 μ s to suspend the erase operation. However, when the Erase Suspend command is written during the sector erase time-out, the device immediately terminates the time-out period and suspends the erase operation.

After the erase operation has been suspended, the system can read array data from or program data to any sector not selected for erasure. (The device “erase suspends” all sectors selected for erasure.) Normal read and write timings and command definitions apply. Reading at any address within erase-suspended sectors produces status data on DQ7–DQ0. The system can use DQ7, or DQ6 and DQ2 together, to determine if a sector is actively erasing or is erase-suspended. See [Write Operation Status on page 28](#) for information on these status bits.

After an erase-suspended program operation is complete, the system can once again read array data within non-suspended sectors. The system can determine the status of the program operation using the DQ7 or DQ6 status bits, just as in the standard program operation. See [Write Operation Status on page 28](#) for more information.

The system may also write the autoselect command sequence when the device is in the Erase Suspend mode. The device allows reading autoselect codes even at addresses within erasing sectors, since the codes are not stored in the memory array. When the device exits the autoselect mode, the device reverts to the Erase Suspend mode, and is ready for another valid operation. See [Autoselect Command Sequence on page 22](#) for more information.

The system must write the Erase Resume command (address bits are *don't care*) to exit the erase suspend mode and continue the sector erase operation. Further writes of the Resume command are ignored. Another Erase Suspend command can be written after the device has resumed erasing.

Figure 7. Erase Operation



Notes

1. See Table 13 on page 26 for erase command sequence.
2. See DQ3: Sector Erase Timer on page 31 for more information.

10.10 Command Definitions Table

Table 13. S29AL008J Command Definitions

Command Sequence (Note 1)			Cycles	Bus Cycles (Notes 2–5)														
				First		Second		Third		Fourth		Fifth		Sixth				
Read (Note 6)			1	RA	RD													
Reset (Note 7)			1	XXX	F0													
Autoselect (Note 8)	Manufacturer ID	Word	4	555	AA	2AA	55	555	90	X00	01							
		Byte		AAA		555		AAA										
	Device ID, Top Boot Block	Word	4	555	AA	2AA	55	555	90	X01	22DA							
		Byte		AAA		555		AAA		X02	DA							
	Device ID, Bottom Boot Block	Word	4	555	AA	2AA	55	555	90	X01	225B							
		Byte		AAA		555		AAA		X02	5B							
	Sector Group Protect Verify (Note 9)	Word	4	555	AA	2AA	55	555	90	(SA) X02	XX00							
		Byte		AAA		555		AAA		(SA) X04	00							
Enter Secured Silicon Sector	Word	3	555	AA	2AA	55	555	88										
	Byte		AAA		555		AAA											

Table 13. S29AL008J Command Definitions (Continued)

Command Sequence (Note 1)		Cycles	Bus Cycles (Notes 2–5)											
			First		Second		Third		Fourth		Fifth		Sixth	
Exit Secured Silicon Sector	Word	4	555	AA	2AA	55	555	90	XXX	00				
	Byte		AAA		555		AAA							
CFI Query (Note 10)	Word	1	55	98										
	Byte		AA											
Program	Word	4	555	AA	2AA	55	555	A0	PA	PD				
	Byte		AAA		555		AAA							
Unlock Bypass	Word	3	555	AA	2AA	55	555	20						
	Byte		AAA		555		AAA							
Unlock Bypass Program (Note 11)		2	XXX	A0	PA	PD								
Unlock Bypass Reset (Note 12)		2	XXX	90	XXX	00								
Chip Erase	Word	6	555	AA	2AA	55	555	80	555	AA	2AA	55	555	10
	Byte		AAA		555		AAA		AAA		555		AAA	
Sector Erase (Note 15)	Word	6	555	AA	2AA	55	555	80	555	AA	2AA	55	SA	30
	Byte		AAA		555		AAA		555		555			
Erase Suspend (Note 13)		1	XXX	B0										
Erase Resume (Note 14)		1	XXX	30										

Legend

X = Don't care
 RA = Address of the memory location to be read
 RD = Data read from location RA during read operation.
 PA = Address of the memory location to be programmed. Addresses latch on the falling edge of the WE# or CE# pulse, whichever happens later.

PD = Data to be programmed at location PA. Data latches on the rising edge of WE# or CE# pulse, whichever happens first.
 SA = Address of the sector to be verified (in autoselect mode) or erased. Address bits A18–A12 uniquely select any sector.

Notes

- See Table 1 on page 9 for description of bus operations.
- All values are in hexadecimal.
- Except for the read cycle and the fourth cycle of the autoselect command sequence, all bus cycles are write cycles.
- Data bits DQ15–DQ8 are don't cares for unlock and command cycles.
- Address bits A18–A11 are don't cares for unlock and command cycles, unless SA or PA required.
- No unlock or command cycles required when reading array data.
- The Reset command is required to return to reading array data when device is in the autoselect mode, or if DQ5 goes high (while the device is providing status data).
- The fourth cycle of the autoselect command sequence is a read cycle.
- The data is 00h for an unprotected sector and 01h for a protected sector. See "Autoselect Command Sequence" for more information.
- Command is valid when device is ready to read array data or when device is in autoselect mode.
- The Unlock Bypass command is required prior to the Unlock Bypass Program command.
- The Unlock Bypass Reset command is required to return to reading array data when the device is in the unlock bypass mode. F0 is also acceptable.
- The system may read and program in non-erasing sectors, or enter the autoselect mode, when in the Erase Suspend mode. The Erase Suspend command is valid only during a sector erase operation.
- The Erase Resume command is valid only during the Erase Suspend mode.
- Additional sector erase commands during the time-out period after an initial sector erase are one cycle long and identical to the sixth cycle of the sector erase command sequence (SA / 30).

11. Write Operation Status

The device provides several bits to determine the status of a write operation: DQ2, DQ3, DQ5, DQ6, DQ7, and RY/BY#. [Table 14 on page 31](#) and the following subsections describe the functions of these bits. DQ7, RY/BY#, and DQ6 each offer a method for determining whether a program or erase operation is complete or in progress. These three bits are discussed first.

11.1 DQ7: Data# Polling

The Data# Polling bit, DQ7, indicates to the host system whether an Embedded Algorithm is in progress or completed, or whether the device is in Erase Suspend. Data# Polling is valid after the rising edge of the final WE# pulse in the program or erase command sequence.

During the Embedded Program algorithm, the device outputs on DQ7 the complement of the datum programmed to DQ7. This DQ7 status also applies to programming during Erase Suspend. When the Embedded Program algorithm is complete, the device outputs the datum programmed to DQ7. The system must provide the program address to read valid status information on DQ7. If a program address falls within a protected sector, Data# Polling on DQ7 is active for approximately 1 μ s, then the device returns to reading array data.

During the Embedded Erase algorithm, Data# Polling produces a 0 on DQ7. When the Embedded Erase algorithm is complete, or if the device enters the Erase Suspend mode, Data# Polling produces a 1 on DQ7. This is analogous to the complement/true datum output described for the Embedded Program algorithm: the erase function changes all the bits in a sector to 1; prior to this, the device outputs the *complement*, or 0. The system must provide an address within any of the sectors selected for erasure to read valid status information on DQ7.

After an erase command sequence is written, if all sectors selected for erasing are protected, Data# Polling on DQ7 is active for approximately 100 μ s, then the device returns to reading array data. If not all selected sectors are protected, the Embedded Erase algorithm erases the unprotected sectors, and ignores the selected sectors that are protected.

When the system detects DQ7 has changed from the complement to true data, it can read valid data at DQ7–DQ0 on the *following* read cycles. This is because DQ7 may change asynchronously with DQ0–DQ6 while Output Enable (OE#) is asserted low. [Figure 21 on page 41](#), illustrates this.

[Write Operation Status on page 31](#) shows the outputs for Data# Polling on DQ7. [Figure 9 on page 30](#) shows the Data# Polling algorithm.

Figure 8. Data# Polling Algorithm

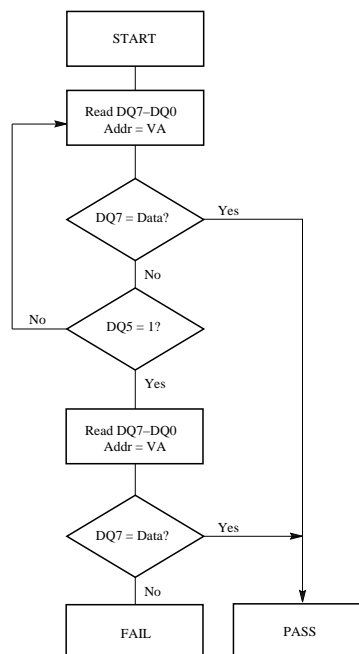

Notes

1. VA = Valid address for programming. During a sector erase operation, a valid address is an address within any sector selected for erasure. During chip erase, a valid address is any non-protected sector address.
2. DQ7 should be rechecked even if DQ5 = 1 because DQ7 may change simultaneously with DQ5.

11.2 RY/BY#: Ready/Busy#

The RY/BY# is a dedicated, open-drain output pin that indicates whether an Embedded Algorithm is in progress or complete. The RY/BY# status is valid after the rising edge of the final WE# pulse in the command sequence. Since RY/BY# is an open-drain output, several RY/BY# pins can be tied together in parallel with a pull-up resistor to V_{CC} .

If the output is low (Busy), the device is actively erasing or programming. (This includes programming in the Erase Suspend mode.) If the output is high (Ready), the device is ready to read array data (including during the Erase Suspend mode), or is in the standby mode.

[Table 14 on page 31](#) shows the outputs for RY/BY#. Figures [Figure 14 on page 36](#), [Figure 15 on page 37](#), [Figure 18 on page 39](#) and [Figure 19 on page 40](#) shows RY/BY# for read, reset, program, and erase operations, respectively.

11.3 DQ6: Toggle Bit I

Toggle Bit I on DQ6 indicates whether an Embedded Program or Erase algorithm is in progress or complete, or whether the device has entered the Erase Suspend mode. Toggle Bit I may be read at any address, and is valid after the rising edge of the final WE# pulse in the command sequence (prior to the program or erase operation), and during the sector erase time-out.

During an Embedded Program or Erase algorithm operation, successive read cycles to any address cause DQ6 to toggle. (The system may use either OE# or CE# to control the read cycles.) When the operation is complete, DQ6 stops toggling.

After an erase command sequence is written, if all sectors selected for erasing are protected, DQ6 toggles for approximately 100 μ s, then returns to reading array data. If not all selected sectors are protected, the Embedded Erase algorithm erases the unprotected sectors, and ignores the selected sectors that are protected.

The system can use DQ6 and DQ2 together to determine whether a sector is actively erasing or is erase-suspended. When the device is actively erasing (that is, the Embedded Erase algorithm is in progress), DQ6 toggles. When the device enters the Erase Suspend mode, DQ6 stops toggling. However, the system must also use DQ2 to determine which sectors are erasing or erase-suspended. Alternatively, the system can use DQ7 (see [DQ7: Data# Polling on page 28](#)).

If a program address falls within a protected sector, DQ6 toggles for approximately 1 μ s after the program command sequence is written, then returns to reading array data.

DQ6 also toggles during the erase-suspend-program mode, and stops toggling once the Embedded Program algorithm is complete.

[Table 14 on page 31](#) shows the outputs for Toggle Bit I on DQ6. [Figure 9 on page 30](#) shows the toggle bit algorithm in flowchart form, and [Reading Toggle Bits DQ6/DQ2 on page 30](#) explains the algorithm. [Figure 22 on page 41](#) shows the toggle bit timing diagrams. [Figure 23 on page 41](#) shows the differences between DQ2 and DQ6 in graphical form. See also the subsection on [DQ2: Toggle Bit II](#).

11.4 DQ2: Toggle Bit II

The “Toggle Bit II” on DQ2, when used with DQ6, indicates whether a particular sector is actively erasing (that is, the Embedded Erase algorithm is in progress), or whether that sector is erase-suspended. Toggle Bit II is valid after the rising edge of the final WE# pulse in the command sequence.

DQ2 toggles when the system reads at addresses within those sectors that have been selected for erasure. (The system may use either OE# or CE# to control the read cycles.) But DQ2 cannot distinguish whether the sector is actively erasing or is erase-suspended. DQ6, by comparison, indicates whether the device is actively erasing, or is in Erase Suspend, but cannot distinguish which sectors are selected for erasure. Thus, both status bits are required for sector and mode information. Refer to [Table 14 on page 31](#) to compare outputs for DQ2 and DQ6.

[Figure 9 on page 30](#) shows the toggle bit algorithm in flowchart form, and the section [Reading Toggle Bits DQ6/DQ2 on page 30](#) explains the algorithm. See also the [DQ6: Toggle Bit I on page 29](#) subsection. [Figure 22 on page 41](#) shows the toggle bit timing diagram. [Figure 23 on page 41](#) shows the differences between DQ2 and DQ6 in graphical form.

11.5 Reading Toggle Bits DQ6/DQ2

Refer to [Figure 9 on page 30](#) for the following discussion. Whenever the system initially begins reading toggle bit status, it must read DQ7–DQ0 at least twice in a row to determine whether a toggle bit is toggling. Typically, the system would note and store the value of the toggle bit after the first read. After the second read, the system would compare the new value of the toggle bit with the first. If the toggle bit is not toggling, the device has completed the program or erase operation. The system can read array data on DQ7–DQ0 on the following read cycle.

However, if after the initial two read cycles, the system determines that the toggle bit is still toggling, the system also should note whether the value of DQ5 is high (see the section on DQ5). If it is, the system should then determine again whether the toggle bit is toggling, since the toggle bit may have stopped toggling just as DQ5 went high. If the toggle bit is no longer toggling, the device has successfully completed the program or erase operation. If it is still toggling, the device did not complete the operation successfully, and the system must write the reset command to return to reading array data.

The remaining scenario is that the system initially determines that the toggle bit is toggling and DQ5 has not gone high. The system may continue to monitor the toggle bit and DQ5 through successive read cycles, determining the status as described in the previous paragraph. Alternatively, it may choose to perform other system tasks. In this case, the system must start at the beginning of the algorithm when it returns to determine the status of the operation (top of [Figure 9 on page 30](#)).

Figure 9. Toggle Bit Algorithm



Notes

1. Read toggle bit twice to determine whether or not it is toggling. See text.
2. Recheck toggle bit because it may stop toggling as DQ5 changes to 1. See text.

11.6 DQ5: Exceeded Timing Limits

DQ5 indicates whether the program or erase time has exceeded a specified internal pulse count limit. Under these conditions DQ5 produces a *1*. This is a failure condition that indicates the program or erase cycle was not successfully completed.

The DQ5 failure condition may appear if the system tries to program a *1* to a location that is previously programmed to *0*. **Only an erase operation can change a *0* back to a *1*.** Under this condition, the device halts the operation, and when the operation has exceeded the timing limits, DQ5 produces a *1*.

Under both these conditions, the system must issue the reset command to return the device to reading array data.

11.7 DQ3: Sector Erase Timer

After writing a sector erase command sequence, the system may read DQ3 to determine whether or not an erase operation has begun. (The sector erase timer does not apply to the chip erase command.) If additional sectors are selected for erasure, the entire time-out also applies after each additional sector erase command. When the time-out is complete, DQ3 switches from *0* to *1*. The system may ignore DQ3 if the system can guarantee that the time between additional sector erase commands will always be less than 50 μ s. See also [Sector Erase Command Sequence on page 25](#).

After the sector erase command sequence is written, the system should read the status on DQ7 (Data# Polling) or DQ6 (Toggle Bit I) to ensure the device has accepted the command sequence, and then read DQ3. If DQ3 is *1*, the internally controlled erase cycle has begun; all further commands (other than Erase Suspend) are ignored until the erase operation is complete. If DQ3 is *0*, the device will accept additional sector erase commands. To ensure the command has been accepted, the system software should check the status of DQ3 prior to and following each subsequent sector erase command. If DQ3 is high on the second status check, the last command might not have been accepted. The following table shows the outputs for DQ3.

Table 14. Write Operation Status

Operation		DQ7 (Note 2)	DQ6	DQ5 (Note 1)	DQ3	DQ2 (Note 2)	RY/BY#
Standard Mode	Embedded Program Algorithm	DQ7#	Toggle	0	N/A	No toggle	0
	Embedded Erase Algorithm	0	Toggle	0	1	Toggle	0
Erase Suspend Mode	Reading within Erase Suspended Sector	1	No toggle	0	N/A	Toggle	1
	Reading within Non-Erase Suspended Sector	Data	Data	Data	Data	Data	1
	Erase-Suspend-Program	DQ7#	Toggle	0	N/A	N/A	0

Notes

- DQ5 switches to 1 when an Embedded Program or Embedded Erase operation has exceeded the maximum timing limits. See [DQ5: Exceeded Timing Limits on page 31](#) for more information.
- DQ7 and DQ2 require a valid address when reading status information. Refer to the appropriate subsection for further details.

12. Absolute Maximum Ratings

Parameter	Rating
Storage Temperature Plastic Packages	-65 °C to +150 °C
Ambient Temperature with Power Applied	-65 °C to +125 °C
Voltage with Respect to Ground	
V_{CC} (Note 1)	-0.5 V to +4.0 V
A9, OE#, and RESET# (Note 2)	-0.5 V to +12.5 V
All other pins (Note 1)	-0.5 V to $V_{CC}+0.5$ V
Output Short Circuit Current (Note 3)	200 mA

Notes

1. Minimum DC voltage on input or I/O pins is -0.5 V. During voltage transitions, input or I/O pins may overshoot V_{SS} to -2.0 V for periods of up to 20 ns. See [Figure 10 on page 33](#). Maximum DC voltage on input or I/O pins is $V_{CC}+0.5$ V. During voltage transitions, input or I/O pins may overshoot to $V_{CC}+2.0$ V for periods up to 20 ns. See [Figure 11 on page 33](#).
2. Minimum DC input voltage on pins A9, OE#, and RESET# is -0.5 V. During voltage transitions, A9, OE#, and RESET# may overshoot V_{SS} to -2.0 V for periods of up to 20 ns. See [Figure 10 on page 33](#). Maximum DC input voltage on pin A9 is +12.5 V which may overshoot to 14.0 V for periods up to 20 ns.
3. No more than one output may be shorted to ground at a time. Duration of the short circuit should not be greater than one second.
4. Stresses above those listed under Absolute Maximum Ratings may cause permanent damage to the device. This is a stress rating only; functional operation of the device at these or any other conditions above those indicated in the operational sections of this data sheet is not implied. Exposure of the device to absolute maximum rating conditions for extended periods may affect device reliability.

13. Operating Ranges

Parameter		Range
Ambient Temperature	Industrial (I) Devices	-40 °C to +85 °C
	Automotive, AEC-Q100 Grade 3 (A) Devices	-40 °C to +85 °C
	Extended (N) Devices	-40 °C to +125 °C
	Automotive, AEC-Q100 Grade 1 (M) Devices	-40 °C to +125 °C
V _{CC} Supply Voltages	Full	2.7 V to 3.6 V
	Regulated	3.0 V to 3.6 V

Note
 Operating ranges define those limits between which the functionality of the device is guaranteed.

Figure 10. Maximum Negative Overshoot Waveform



Figure 11. Maximum Positive Overshoot Waveform

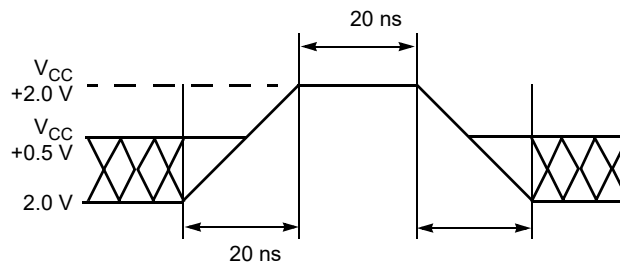

14. DC Characteristics

14.1 CMOS Compatible

Parameter	Description	Test Conditions	Min	Typ	Max	Unit
I_{LI}	Input Load Current	$V_{IN} = V_{SS}$ to V_{CC} , $V_{CC} = V_{CC\ max}$			± 1.0	μA
	WP# Input Load Current	$V_{CC} = V_{CC\ max}$, WP# = V_{SS} to V_{CC}			± 25	
I_{LIT}	A9 Input Load Current	$V_{CC} = V_{CC\ max}$; A9 = 12.5 V			35	μA
I_{LO}	Output Leakage Current	$V_{OUT} = V_{SS}$ to V_{CC} , $V_{CC} = V_{CC\ max}$			± 1.0	
I_{CC1}	V_{CC} Active Read Current (Note 1)	$CE\# = V_{IL}$, $OE\# = V_{IH}$, $V_{CC} = V_{CC\ max}$, Byte Mode	5 MHz	7	12	mA
			1 MHz	2	4	
		$CE\# = V_{IL}$, $OE\# = V_{IH}$, $V_{CC} = V_{CC\ max}$, Word Mode	5 MHz	7	12	
			1 MHz	2	4	
I_{CC2}	V_{CC} Active Erase/Program Current (Notes 2, 3, 4)	$CE\# = V_{IL}$, $OE\# = V_{IH}$, $V_{CC} = V_{CC\ max}$		20	30	mA
I_{CC3}	V_{CC} Standby Current (Note 4)	$OE\# = V_{IH}$, $CE\#, RESET\# = V_{CC} \pm 0.3\ V/-0.1\ V$, WP# = V_{CC} or open, $V_{CC} = V_{CC\ max}$ (Note 5)		0.2	5	μA
I_{CC4}	V_{CC} Standby Current During Reset (Note 4)	$V_{CC} = V_{CC\ max}$; RESET# = $V_{SS} \pm 0.3\ V/-0.1\ V$ WP# = V_{CC} or open, (Note 5)		0.2	5	μA
I_{CC5}	Automatic Sleep Mode (Notes 3, 4)	$V_{CC} = V_{CC\ max}$, $V_{IH} = V_{CC} \pm 0.3\ V$, $V_{IL} = V_{SS} \pm 0.3\ V/-0.1\ V$, WP# = V_{CC} or open, (Note 5)		0.2	5	μA
V_{IL}	Input Low Voltage		-0.1		0.8	V
V_{IH}	Input High Voltage		$0.7 \times V_{CC}$		$V_{CC} + 0.3$	
V_{ID}	Voltage for Autoselect and Temporary Sector Unprotect	$V_{CC} = 2.7\text{--}3.6\ V$	8.5		12.5	
V_{OL}	Output Low Voltage	$I_{OL} = 4.0\ mA$, $V_{CC} = V_{CC\ min}$			0.45	
V_{OH1}	Output High Voltage	$I_{OH} = -2.0\ mA$, $V_{CC} = V_{CC\ min}$	$0.85 \times V_{CC}$			
V_{OH2}		$I_{OH} = -100\ \mu A$, $V_{CC} = V_{CC\ min}$	$V_{CC} - 0.4$			
V_{LKO}	Low V_{CC} Lock-Out Voltage		2.1		2.5	

Notes

- The I_{CC} current listed is typically less than 2 mA/MHz, with OE# at V_{IH} . Typical V_{CC} is 3.0 V.
- I_{CC} active while Embedded Erase or Embedded Program is in progress.
- Automatic sleep mode enables the low power mode when addresses remain stable for $t_{ACC} + 30\ ns$.
- Not 100% tested.
- When device operated in Extended Temperature range, the currents shall be as follows:
 - $I_{CC3} = 0.2\ \mu A$ (typ), 10 μA (max)
 - $I_{CC4} = 0.2\ \mu A$ (typ), 10 μA (max)
 - $I_{CC5} = 0.2\ \mu A$ (typ), 10 μA (max)

15. Test Conditions

Figure 12. Test Setup



Note
Diodes are 1N3064 or equivalent.

Table 15. Test Specifications

Test Condition	70	55	Unit
Output Load	1 TTL gate		
Output Load Capacitance, C_L (including jig capacitance)	30		pF
Input Rise and Fall Times	5		ns
Input Pulse Levels	0.0 or V_{CC}		V
Input timing measurement reference levels	0.5 V_{CC}		
Output timing measurement reference levels	0.5 V_{CC}		

16. Key to Switching Waveforms

Waveform	Inputs	Outputs
	Steady	
	Changing from H to L	
	Changing from L to H	
	Don't Care, Any Change Permitted	Changing, State Unknown
	Does Not Apply	Center Line is High Impedance State (High Z)

Figure 13. Input Waveforms and Measurement Levels



17. AC Characteristics

17.1 Read Operations

Parameter		Description	Test Setup	Speed Options		Unit	
JEDEC	Std			55	70		
t_{AVAV}	t_{RC}	Read Cycle Time (Note 1)	Min	55	70	ns	
t_{AVQV}	t_{ACC}	Address to Output Delay	CE# = V_{IL} OE# = V_{IL}	Max	55		70
t_{ELQV}	t_{CE}	Chip Enable to Output Delay	OE# = V_{IL}	Max	55		70
t_{GLQV}	t_{OE}	Output Enable to Output Delay		Max	30		30
t_{EHQZ}	t_{DF}	Chip Enable to Output High Z (Note 1)		Max	16		
t_{GHQZ}	t_{DF}	Output Enable to Output High Z (Note 1)		Max	16		
	$t_{SR/W}$	Latency Between Read and Write Operations		Min	20		
	t_{OEh}	Output Enable Hold Time (Note 1)	Read	Min	0		
		Toggle and Data# Polling		Min	10		
t_{AXQX}	t_{OH}	Output Hold Time From Addresses, CE# or OE#, Whichever Occurs First (Note 1)		Min	0		

Notes

1. Not 100% tested.
2. See Figure 12 on page 35 and Table 15 on page 35 for test specifications.

Figure 14. Read Operations Timings



17.2 Hardware Reset (RESET#)

Parameter		Description	Test Setup	All Speed Options	Unit
JEDEC	Std				
	t_{READY}	RESET# Pin Low (During Embedded Algorithms) to Read or Write (See Note)	Max	35	μs
	t_{READY}	RESET# Pin Low (NOT During Embedded Algorithms) to Read or Write (See Note)	Max	500	ns
	t_{RP}	RESET# Pulse Width	Min	500	
	t_{RH}	RESET# High Time Before Read (See Note)		50	
	t_{RPD}	RESET# Low to Standby Mode		35	μs
	t_{RB}	RY/BY# Recovery Time		0	ns

Note
Not 100% tested.

Figure 15. RESET# Timings

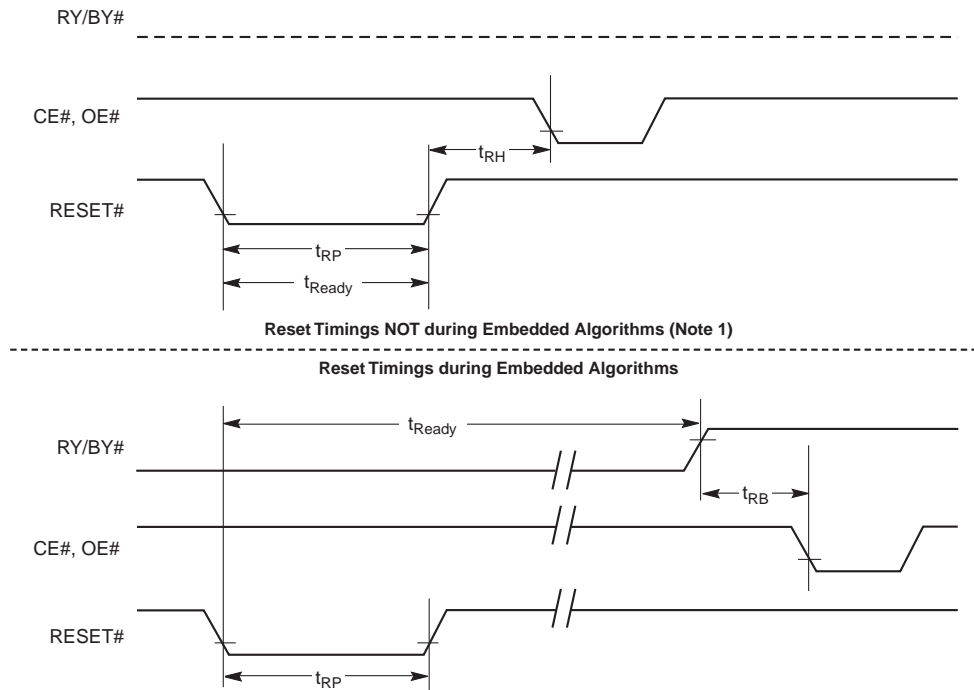

Note
1. CE# should only go low after RESET# has gone high. Keeping CE# low from power up through the first read could cause the first read to retrieve erroneous data.

17.3 Word/Byte Configuration (BYTE#)

Parameter		Description		Speed Options		Unit
JEDEC	Std			55	70	
	t_{ELFL}/t_{ELFH}	CE# to BYTE# Switching Low or High	Max	5		ns
	t_{FLQZ}	BYTE# Switching Low to Output HIGH Z	Max	16		
	t_{FHQV}	BYTE# Switching High to Output Active	Min	55	70	

Figure 16. BYTE# Timings for Read Operations



Figure 17. BYTE# Timings for Write Operations



Note
Refer to the Erase/Program Operations table for t_{AS} and t_{AH} specifications.

17.4 Erase/Program Operations

Parameter		Description		Speed Options		Unit
JEDEC	Std			55	70	
t_{AVAV}	t_{WC}	Write Cycle Time (Note 1)	Min	55	70	ns
t_{AVWL}	t_{AS}	Address Setup Time	Min	0		ns
t_{WLAX}	t_{AH}	Address Hold Time	Min	45		ns
t_{DVWH}	t_{DS}	Data Setup Time	Min	35	35	ns
t_{WHDX}	t_{DH}	Data Hold Time	Min	0		ns
	t_{OES}	Output Enable Setup Time	Min	0		ns
t_{GHWL}	t_{GHWL}	Read Recovery Time Before Write (OE# High to WE# Low)	Min	0		ns
t_{ELWL}	t_{CS}	CE# Setup Time	Min	0		ns
t_{WHEH}	t_{CH}	CE# Hold Time	Min	0		ns
t_{WLWH}	t_{WP}	Write Pulse Width	Min	35	35	ns
t_{WHWL}	t_{WPH}	Write Pulse Width High	Min	25		ns
	t_{SRW}	Latency Between Read and Write Operations	Min	20		ns
t_{WHWH1}	t_{WHWH1}	Programming Operation (Note 2)	Byte	Typ	6	μ s
			Word	Typ	6	
t_{WHWH2}	t_{WHWH2}	Sector Erase Operation (Note 2)	Typ	0.5		sec
	t_{VCS}	V_{CC} Setup Time (Note 1)	Min	50		μ s
	t_{RB}	Recovery Time from RY/BY#	Min	0		ns
	t_{BUSY}	Program/Erase Valid to RY/BY# Delay	Max	90		

Notes

1. Not 100% tested.
2. See *Erase and Programming Performance* on page 44 for more information.

Figure 18. Program Operation Timings



Notes

1. PA = program address, PD = program data, D_{OUT} is the true data at the program address.
2. Illustration shows device in word mode.

Figure 19. Chip/Sector Erase Operation Timings



Notes

1. SA = sector address (for Sector Erase), VA = Valid Address for reading status data (see [Write Operation Status on page 28](#)).
2. Illustration shows device in word mode.

Figure 20. Back to Back Read/Write Cycle Timing



Figure 21. Data# Polling Timings (During Embedded Algorithms)

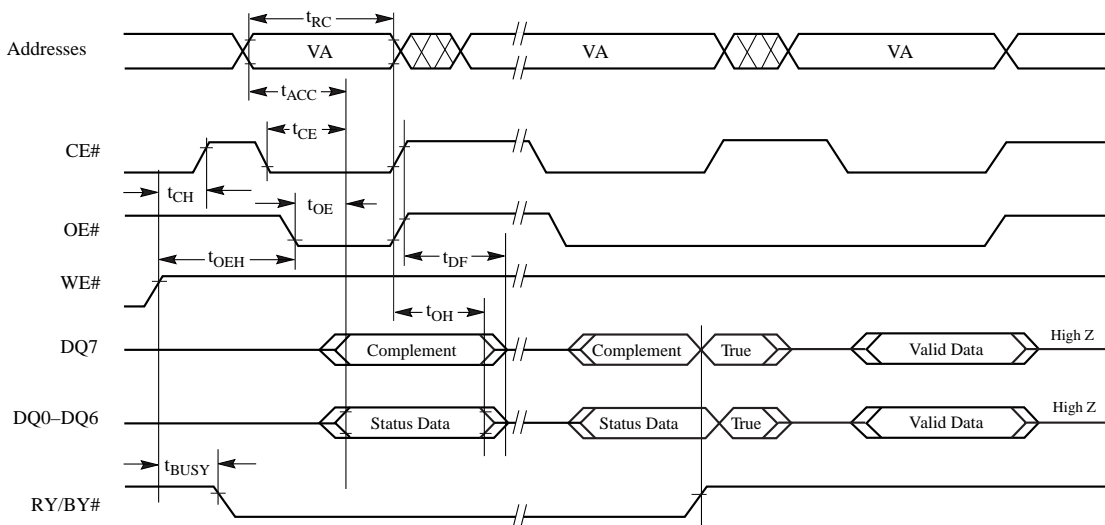

Note

VA = Valid address. Illustration shows first status cycle after command sequence, last status read cycle, and array data read cycle.

Figure 22. Toggle Bit Timings (During Embedded Algorithms)

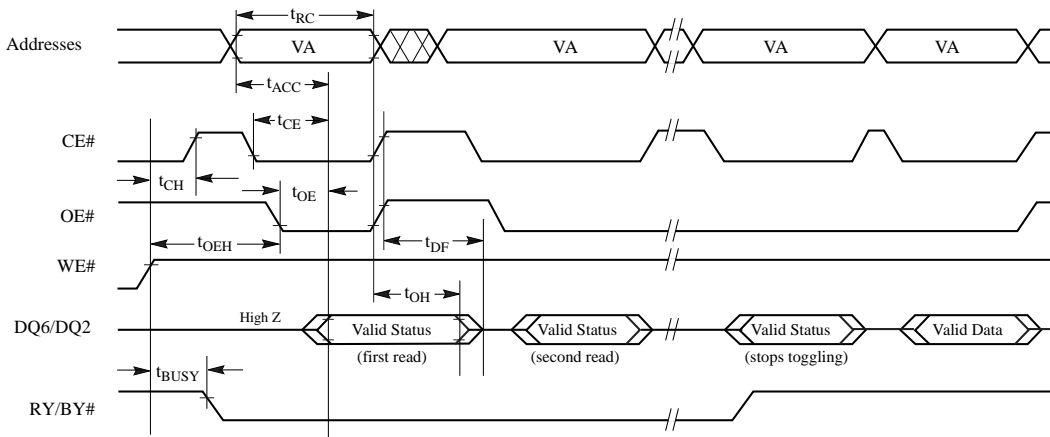

Note

VA = Valid address; not required for DQ6. Illustration shows first two status cycle after command sequence, last status read cycle, and array data read cycle.

Figure 23. DQ2 vs. DQ6 for Erase and Erase Suspend Operations

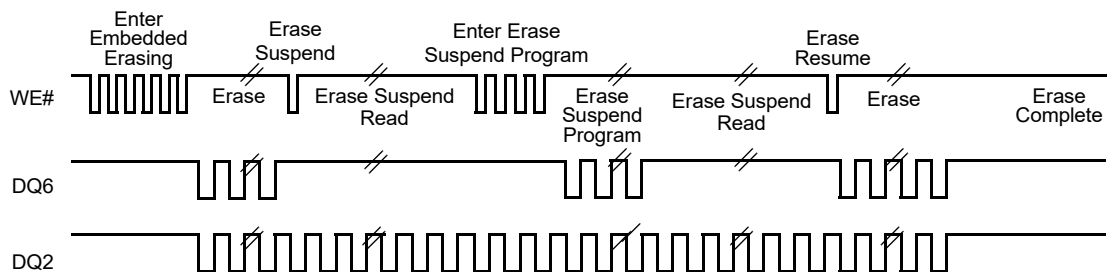

Note

The system may use CE# or OE# to toggle DQ2 and DQ6. DQ2 toggles only when read at an address within an erase-suspended sector.

17.5 Temporary Sector Group Unprotect

Parameter		Description		All Speed Options	Unit
JEDEC	Std				
	t_{VIDR}	V_{ID} Rise and Fall Time (See Note)	Min	500	ns
	t_{RSP}	RESET# Setup Time for Temporary Sector Unprotect	Min	4	μ s
	t_{RRB}	RESET# Hold Time from RY/BY# High for Temporary Sector Unprotect	Min	4	μ s

Note
Not 100% tested.

Figure 24. Temporary Sector Group Unprotect/Timing Diagram

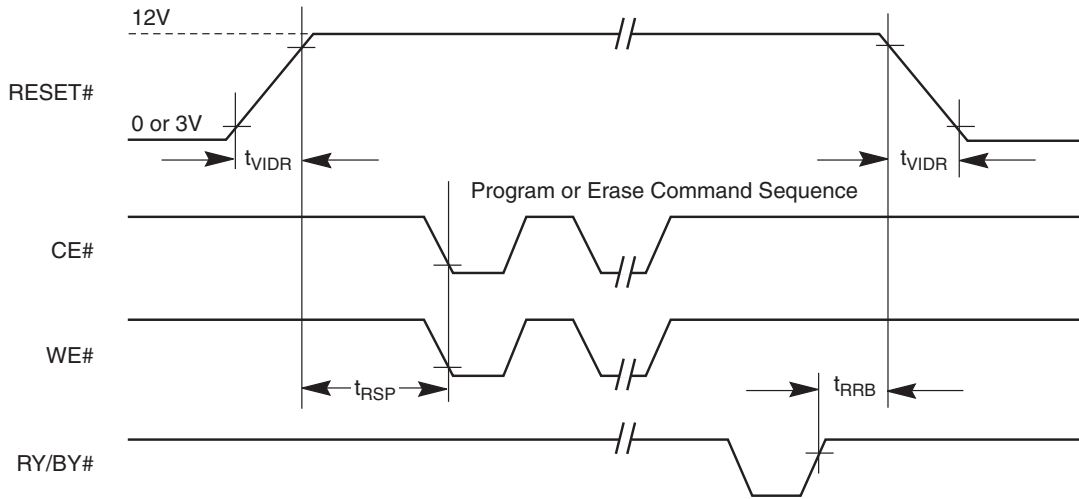
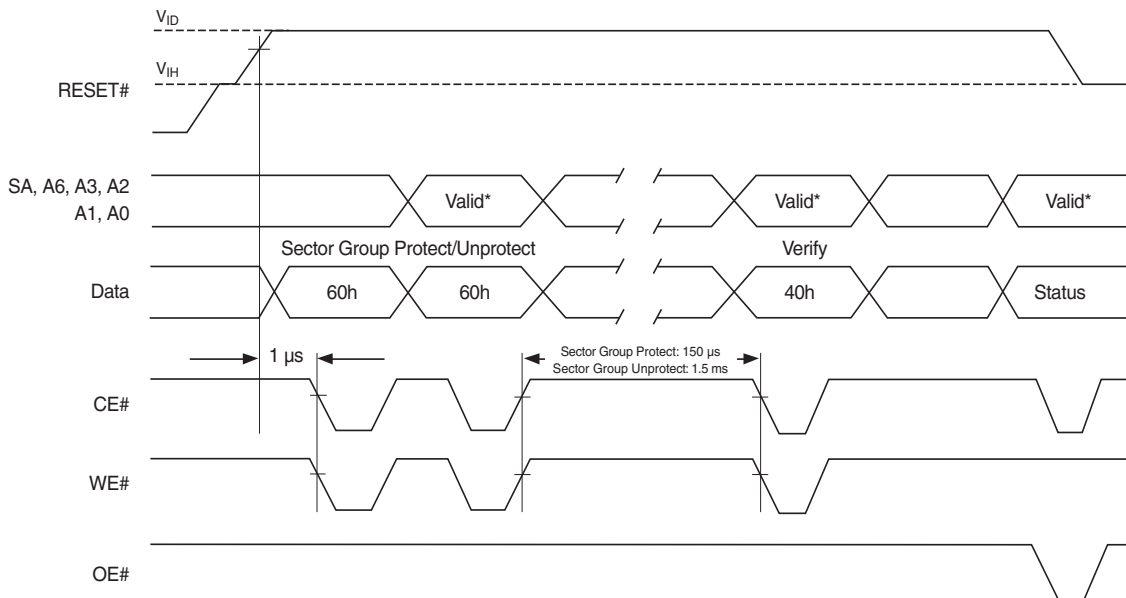

Figure 25. Sector Group Protect/Unprotect Timing Diagram



Note
For sector group protect, A6 = 0, A3 = A2 = 0, A1 = 1, A0 = 0. For sector unprotect, A6 = 1, A3 = A2 = 0, A1 = 1, A0 = 0.

17.6 Alternate CE# Controlled Erase/Program Operations

Parameter		Description		Speed Options		Unit
JEDEC	Std			55	70	
t_{AVAV}	t_{WC}	Write Cycle Time (Note 1)	Min	55	70	ns
t_{AVEL}	t_{AS}	Address Setup Time	Min	0		ns
t_{ELAX}	t_{AH}	Address Hold Time	Min	45		ns
t_{DVEH}	t_{DS}	Data Setup Time	Min	35	35	ns
t_{EHDX}	t_{DH}	Data Hold Time	Min	0		ns
	t_{OES}	Output Enable Setup Time	Min	0		ns
t_{GHEL}	t_{GHEL}	Read Recovery Time Before Write (OE# High to WE# Low)	Min	0		ns
t_{WLEL}	t_{WS}	WE# Setup Time	Min	0		ns
t_{EHWH}	t_{WH}	WE# Hold Time	Min	0		ns
t_{ELEH}	t_{CP}	CE# Pulse Width	Min	35	35	ns
t_{EHEL}	t_{CPH}	CE# Pulse Width High	Min	25		ns
	t_{SRW}	Latency Between Read and Write Operations	Min	20		ns
t_{WHWH1}	t_{WHWH1}	Programming Operation (Note 2)	Byte	Typ	6	μ s
			Word	Typ	6	
t_{WHWH2}	t_{WHWH2}	Sector Erase Operation (Note 2)	Typ	0.5		sec

Notes

1. Not 100% tested.
2. See *Erase and Programming Performance* on page 44 for more information.

Figure 26. Alternate CE# Controlled Write Operation Timings

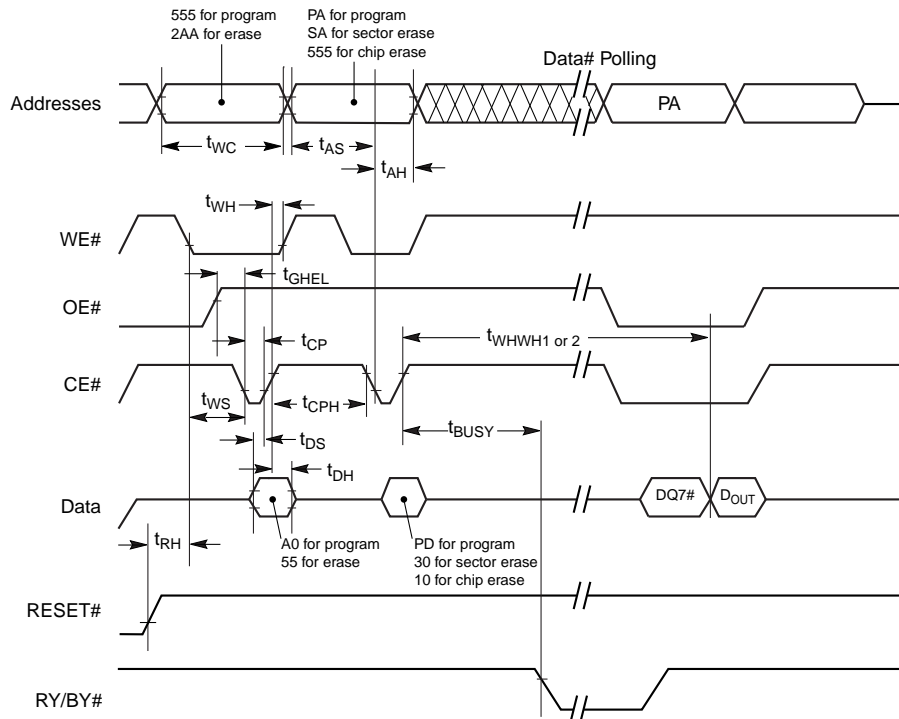

Notes

1. PA = program address, PD = program data, DQ7# = complement of the data written to the device, DOUT = data written to the device.
2. Figure indicates the last two bus cycles of the command sequence.
3. Word mode address used as an example.

18. Erase and Programming Performance

Parameter		Typ (Note 1)	Max (Note 2)	Unit	Comments
Sector Erase Time		0.5	10	s	Excludes 00h programming prior to erasure (Note 4)
Chip Erase Time		10		s	
Byte Programming Time		6	150	μs	Excludes system level overhead (Note 5)
Word Programming Time		6	150	μs	
Chip Programming Time	Byte Mode	6.3	80	s	
	Word Mode	3.2	60	s	

Notes

1. Typical program and erase times assume the following conditions: 25°C, $V_{CC} = 3.0\text{ V}$, 100,000 cycles, checkerboard data pattern.
2. Under worst case conditions of 90°C, $V_{CC} = 2.7\text{ V}$, 1,000,000 cycles.
3. The typical chip programming time is considerably less than the maximum chip programming time listed, since most bytes program faster than the maximum program times listed.
4. In the pre-programming step of the Embedded Erase algorithm, all bytes are programmed to 00h before erasure.
5. System-level overhead is the time required to execute the two- or four-bus-cycle sequence for the program command. See Table 13 on page 26 for further information on command definitions.
6. The device has a minimum erase and program cycle endurance of 100,000 cycles per sector.

19. TSOP and BGA Pin Capacitance

Parameter Symbol	Parameter Description	Test Setup	Package	Typ	Max	Unit
C_{IN}	Input Capacitance	$V_{IN} = 0$	TSOP	4	6	pF
			BGA	4	6	
C_{OUT}	Output Capacitance	$V_{OUT} = 0$	TSOP	4.5	5.5	
			BGA	4.5	5.5	
C_{IN2}	Control Pin Capacitance	$V_{IN} = 0$	TSOP	5	6.5	
			BGA	5	6.5	
C_{IN3}	WP# Pin Capacitance	$V_{IN} = 0$	TSOP	8.5	10	
			BGA	8.5	10	

Notes

1. Sampled, not 100% tested.
2. Test conditions $T_A = 25^\circ\text{C}$, $f = 1.0\text{ MHz}$.

20. Physical Dimensions

20.1 48-Pin TSOP (18.4 mm × 12.0 mm × 1.2 mm) Package Outline



SYMBOL	DIMENSIONS		
	MIN.	NOM.	MAX.
A	—	—	1.20
A1	0.05	—	0.15
A2	0.95	1.00	1.05
b1	0.17	0.20	0.23
b	0.17	0.22	0.27
c1	0.10	—	0.16
c	0.10	—	0.21
D	20.00 BASIC		
D1	18.40 BASIC		
E	12.00 BASIC		
e	0.50 BASIC		
L	0.50	0.60	0.70
θ	0°	—	8
R	0.08	—	0.20
N	48		

NOTES:

1. DIMENSIONS ARE IN MILLIMETERS (mm).
2. PIN 1 IDENTIFIER FOR STANDARD PIN OUT (DIE UP).
3. PIN 1 IDENTIFIER FOR REVERSE PIN OUT (DIE DOWN): INK OR LASER MARK.
4. TO BE DETERMINED AT THE SEATING PLANE [C]. THE SEATING PLANE IS DEFINED AS THE PLANE OF CONTACT THAT IS MADE WHEN THE PACKAGE LEADS ARE ALLOWED TO REST FREELY ON A FLAT HORIZONTAL SURFACE.
5. DIMENSIONS D1 AND E DO NOT INCLUDE MOLD PROTRUSION. ALLOWABLE MOLD PROTRUSION ON E IS 0.15mm PER SIDE AND ON D1 IS 0.25mm PER SIDE.
6. DIMENSION b DOES NOT INCLUDE DAMBAR PROTRUSION. ALLOWABLE DAMBAR PROTRUSION SHALL BE 0.08mm TOTAL IN EXCESS OF b DIMENSION AT MAX. MATERIAL CONDITION. DAMBAR CANNOT BE LOCATED ON LOWER RADIUS OR THE FOOT. MINIMUM SPACE BETWEEN PROTRUSION AND AN ADJACENT LEAD TO BE 0.07mm.
7. THESE DIMENSIONS APPLY TO THE FLAT SECTION OF THE LEAD BETWEEN 0.10mm AND 0.25mm FROM THE LEAD TIP.
8. LEAD COPLANARITY SHALL BE WITHIN 0.10mm AS MEASURED FROM THE SEATING PLANE.
9. DIMENSION "e" IS MEASURED AT THE CENTERLINE OF THE LEADS.
10. JEDEC SPECIFICATION NO. REF: MO-142(D)DD.

51-85183 *F

Note
For reference only. BSC is an ANSI standard for Basic Space Centering.

20.2 48-Ball VFBGA (8.15 mm x 6.15 mm x 1.00 mm) Package Outline



SYMBOL	DIMENSIONS		
	MIN.	NOM.	MAX.
A	-	-	1.00
A1	0.18	-	-
D	8.15 BSC.		
E	6.15 BSC.		
D1	5.60 BSC.		
E1	4.00 BSC.		
MD	8		
ME	6		
n	48		
φb	0.33	-	0.43
eD/eE	0.80 BSC.		
SD/SE	0.40 BSC.		

NOTES:

- DIMENSIONING AND TOLERANCING PER ASME Y14.5M-1994 .
- ALL DIMENSIONS ARE IN MILLIMETERS .
- BALL POSITION DESIGNATION PER JEP95, SECTION 3, SPP-010/020.
- [a] REPRESENTS THE SOLDER BALL GRID PITCH .
- SYMBOL "MD" IS THE BALL ROW MATRIX SIZE IN THE "D" DIRECTION.
SYMBOL "ME" IS THE BALL COLUMN MATRIX SIZE IN THE "E" DIRECTION.
n IS THE TOTAL NUMBER OF POPULATED SOLDER BALLS FOR MATRIX SIZE MD AND ME.
- △a DIMENSION "b" IS MEASURED AT THE MAXIMUM BALL DIAMETER IN A PLANE PARALLEL TO DATUM C.
- △ "SD" AND "SE" ARE MEASURED WITH RESPECT TO DATUMS A AND B AND DEFINE THE POSITION OF THE CENTER SOLDER BALL IN THE OUTER ROW.
WHEN THERE IS AN ODD NUMBER OF SOLDER BALLS IN THE OUTER ROW, "SD" OR "SE" = 0.
WHEN THERE IS AN EVEN NUMBER OF SOLDER BALLS IN THE OUTER ROW, "SD" = eD/2 and "SE" = eE/2.
- "+" INDICATES THE THEORETICAL CENTER OF DEPOPULATED BALLS.
- △a A1 CORNER TO BE IDENTIFIED BY CHAMFER, LASER OR INK MARK, METALLIZED MARK INDENTATION OR OTHER MEANS.

002-19063 **

21. Revision History

Document History Page

Document Title: S29AL008J, 8-Mbit (1M × 8-Bit/512K × 16-Bit), 3 V, Boot Sector Flash Document Number: 002-00778				
Rev.	ECN No.	Orig. of Change	Submission Date	Description of Change
**	–	RYSU	06/26/2007	Initial release
*A	–	RYSU	10/29/2007	Distinctive Characteristics Corrected number of 64 Kbyte / 32 Kword sectors Global Removed 44-pin SOP package Ordering Information Removed all leaded package offerings S29AL008J Device Bus Operations Table Under Note 3: Removed the line "If WP# = VHH, all sectors will be unprotected." CFI Query Identification String Table Updated the data for CFI addresses 2C hex & 39 hex S29AL008J Command Definitions Table The 2nd cycle data for the "Unlock Bypass Reset" command was updated from 'F0' to '00'. Absolute Maximum Ratings Updated VCC Absolute Maximum Rating CMOS Compatible Table Updated ICC3 Standby current test condition Updated maximum value of VOL Updated minimum value of VLKO Figure Back to Back Read/Write Cycle Timing Corrected the tSRW duration
*B	–	RYSU	03/27/2008	Reset #: Hardware Reset Pin Updated current consumption during RESET# pulse CMOS Compatible Table Updated maximum value of ILI Updated test condition, typical and maximum value of Icc3 Updated test condition, typical and maximum value of Icc4 Updated test condition, typical and maximum value of Icc5 Updated minimum value of VIL Added Note 5 Ordering Information Updated valid combination • Removed 45 ns, added 70 ns
*C	–	RYSU	05/23/2008	Global Removed fortified BGA package option Ordering Information Added the Regulated Voltage option Added the Extended Temperature Range Updated the Valid Combination table Pin Configuration Updated Pin Configuration table Device Bus Operation Updated the S29AL008J Device Bus Operation table and modified Note 3 Operating Ranges Added Extended Temperature Range information Added Regulated Voltage

Document History Page (Continued)

Document Title: S29AL008J, 8-Mbit (1M × 8-Bit/512K × 16-Bit), 3 V, Boot Sector Flash Document Number: 002-00778				
Rev.	ECN No.	Orig. of Change	Submission Date	Description of Change
*D	–	RYSU	08/12/2008	Sector Protection/Unprotection Title changed to Sector Group Protection and Unprotection Section amended and restated to Sector Group Protection and Unprotection Temporary Sector Unprotect Title changed to Temporary Sector Group Unprotect Figure 7.1; Title changed to Temporary Sector Group Unprotect Operation Figure 7.2; Title changed to In-System Sector Protect/Unprotect Algorithms Temporary Sector Unprotect Title changed to Temporary Sector Group Unprotect Figure 17.11; Title changed to Temporary Sector Group Unprotect/Timing Diagram Figure 17.12; Sector Group Protect/Unprotect Timing Diagram Reading Toggle Bits DQ6/DQ2 Updated Figure 11.2 Ordering Information Added SSOP56 package option Updated the Valid Combination table Connection Diagrams Added 56-pin Shrink Small Outline Package (SSOP56) Physical Dimensions Added 56-pin Shrink Small Outline Package (SSOP56) Alternate CE# Controlled Erase/Program Operations TDS value changed from 45 ns to 35 ns Erase/Program Operation Added figure Toggle Bit Timing (During Embedded Algorithm) Product Selector Guide Updated Table
*E	–	RYSU	10/29/2008	Customer Lockable: Secured Silicon Sector Programmed and Protected at the Factory Modified first bullet Updated figure Secured Silicon Sector Protect Verify TSOP and Pin Capacitance Updated Table
*F	–	RYSU	02/03/2009	Ordering Information Updated the Valid Combination table Erase/Program Operation Updated Table Removed Figure <i>Toggle Bit Timing (During Embedded Algorithm)</i> Erase and Programming Performance Updated Table
*G	–	RYSU	07/09/2009	General Corrected minor typos Physical Dimensions Updated TS048 Customer Lockable: Secured Silicon Sector NOT Programmed and Protected at the Factory Modified first bullet Erase and Programming Performance Updated Table
*H	–	RYSU	02/23/2010	Sector Erase Command Sequence Added clarification regarding additional sector erase commands during time-out period Command Definitions Table Added Note 15 to clarify additional sector erase commands during time-out period
*I	–	RYSU	12/09/2011	Ordering Information Added Low-Halogen 48-ball BGA ordering option RESET#: Hardware Reset Pin Added sentence regarding use of CE# with RESET# RESET# Timings Figure Added note
*J	–	RYSU	04/12/2012	Global Removed SSOP-56
*K	5042120	RYSU	12/11/2015	Updated to Cypress template.
*L	5690582	HARA	04/27/2017	Updated logo and copyright.

Document History Page (Continued)

Document Title: S29AL008J, 8-Mbit (1M × 8-Bit/512K × 16-Bit), 3 V, Boot Sector Flash Document Number: 002-00778				
Rev.	ECN No.	Orig. of Change	Submission Date	Description of Change
*M	5768904	PRIT	06/09/2017	Updated Ordering Information : Updated S29AL008J Standard Products : Added Automotive Temperature Range related information. Added Valid Combinations – Automotive Grade / AEC-Q100 .
*N	5812614	PRIT	07/13/2017	Updated Ordering Information : Updated Valid Combinations – Automotive Grade / AEC-Q100 : Updated details in the table. Updated to new template.
*O	5923085	PRIT	10/12/2017	Updated Physical Dimensions : Updated 48-Ball VFBGA (8.15 mm x 6.15 mm × 1.00 mm) Package Outline : Updated diagram (to show dimensions table).
*P	6132765	PRIT	04/11/2018	Updated to new template. Completing Sunset Review.

Sales, Solutions, and Legal Information

Worldwide Sales and Design Support

Cypress maintains a worldwide network of offices, solution centers, manufacturer's representatives, and distributors. To find the office closest to you, visit us at [Cypress Locations](#).

Products

Arm® Cortex® Microcontrollers	cypress.com/arm
Automotive	cypress.com/automotive
Clocks & Buffers	cypress.com/clocks
Interface	cypress.com/interface
Internet of Things	cypress.com/iot
Memory	cypress.com/memory
Microcontrollers	cypress.com/mcu
PSoC	cypress.com/psoc
Power Management ICs	cypress.com/pmic
Touch Sensing	cypress.com/touch
USB Controllers	cypress.com/usb
Wireless Connectivity	cypress.com/wireless

PSoC® Solutions

[PSoC 1](#) | [PSoC 3](#) | [PSoC 4](#) | [PSoC 5LP](#) | [PSoC 6 MCU](#)

Cypress Developer Community

[Community](#) | [Projects](#) | [Video](#) | [Blogs](#) | [Training](#) | [Components](#)

Technical Support

cypress.com/support

© Cypress Semiconductor Corporation, 2007-2018. This document is the property of Cypress Semiconductor Corporation and its subsidiaries, including Spansion LLC ("Cypress"). This document, including any software or firmware included or referenced in this document ("Software"), is owned by Cypress under the intellectual property laws and treaties of the United States and other countries worldwide. Cypress reserves all rights under such laws and treaties and does not, except as specifically stated in this paragraph, grant any license under its patents, copyrights, trademarks, or other intellectual property rights. If the Software is not accompanied by a license agreement and you do not otherwise have a written agreement with Cypress governing the use of the Software, then Cypress hereby grants you a personal, non-exclusive, nontransferable license (without the right to sublicense) (1) under its copyright rights in the Software (a) for Software provided in source code form, to modify and reproduce the Software solely for use with Cypress hardware products, only internally within your organization, and (b) to distribute the Software in binary code form externally to end users (either directly or indirectly through resellers and distributors), solely for use on Cypress hardware product units, and (2) under those claims of Cypress's patents that are infringed by the Software (as provided by Cypress, unmodified) to make, use, distribute, and import the Software solely for use with Cypress hardware products. Any other use, reproduction, modification, translation, or compilation of the Software is prohibited.

TO THE EXTENT PERMITTED BY APPLICABLE LAW, CYPRESS MAKES NO WARRANTY OF ANY KIND, EXPRESS OR IMPLIED, WITH REGARD TO THIS DOCUMENT OR ANY SOFTWARE OR ACCOMPANYING HARDWARE, INCLUDING, BUT NOT LIMITED TO, THE IMPLIED WARRANTIES OF MERCHANTABILITY AND FITNESS FOR A PARTICULAR PURPOSE. No computing device can be absolutely secure. Therefore, despite security measures implemented in Cypress hardware or software products, Cypress does not assume any liability arising out of any security breach, such as unauthorized access to or use of a Cypress product. In addition, the products described in these materials may contain design defects or errors known as errata which may cause the product to deviate from published specifications. To the extent permitted by applicable law, Cypress reserves the right to make changes to this document without further notice. Cypress does not assume any liability arising out of the application or use of any product or circuit described in this document. Any information provided in this document, including any sample design information or programming code, is provided only for reference purposes. It is the responsibility of the user of this document to properly design, program, and test the functionality and safety of any application made of this information and any resulting product. Cypress products are not designed, intended, or authorized for use as critical components in systems designed or intended for the operation of weapons, weapons systems, nuclear installations, life-support devices or systems, other medical devices or systems (including resuscitation equipment and surgical implants), pollution control or hazardous substances management, or other uses where the failure of the device or system could cause personal injury, death, or property damage ("Unintended Uses"). A critical component is any component of a device or system whose failure to perform can be reasonably expected to cause the failure of the device or system, or to affect its safety or effectiveness. Cypress is not liable, in whole or in part, and you shall and hereby do release Cypress from any claim, damage, or other liability arising from or related to all Unintended Uses of Cypress products. You shall indemnify and hold Cypress harmless from and against all claims, costs, damages, and other liabilities, including claims for personal injury or death, arising from or related to any Unintended Uses of Cypress products.

Cypress, the Cypress logo, Spansion, the Spansion logo, and combinations thereof, WICED, PSoC, CapSense, EZ-USB, F-RAM, and Traveo are trademarks or registered trademarks of Cypress in the United States and other countries. For a more complete list of Cypress trademarks, visit cypress.com. Other names and brands may be claimed as property of their respective owners.