

Instruction Manual for Evaluation Board of the TC78H621FNG

May 10, 2022

Rev.2.0

【Outline】

The TC78H621FNG is a 2-channel brushed DC motor driver corresponding to the direct PWM control system. This product is capable of driving up to 2 brushed DC motors or 1 bipolar stepping motor. CD process is adopted and the rating of 18V and 1.1A are realized.

This evaluation board mounts necessary components to evaluate the IC. Two brushed motors can be controlled by the direct PWM drive.

Mounting a connector for a stepping motor also enables a stepping motor control. Please sense controllability of a brushed DC motor by applying the TC78H621FNG.

【Note】

In using, please be careful about the thermal condition sufficiently.

For each control signal, please refer to the IC specifications by accessing to the following URL:

<http://toshiba.semicon-storage.com/ap-en/product/linear/motordriver/detail.TC78H621FNG.html>

Further, the application of this evaluation board is limited to the purpose of evaluating and learning the motor control. Please do not ship them to a market.

Connection to Evaluation Board

Correspondence table of silk name and signal name

Please pay attention that the silk name and the signal name of the board are different because the TC78H621FNG and the series ICs use the common board.

Silk name	Signal name	DIP SW number
IN1A	EN_A	2
IN2A	PHA_A	1
/STB	/STB	3
IN1B	EN_B	5
IN2B	PHA_B	4

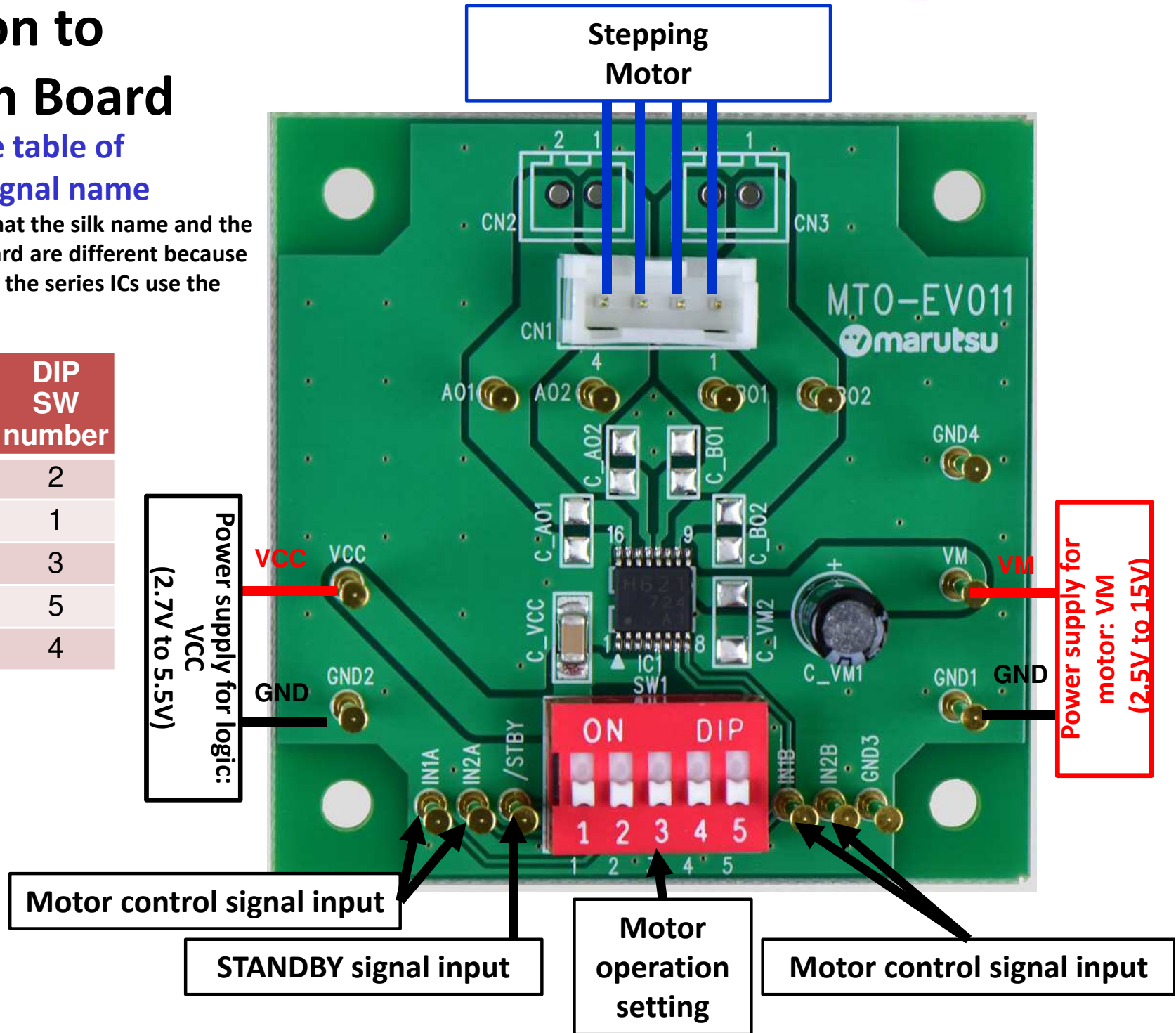

Setting Evaluation Board

Setting Motor Operation

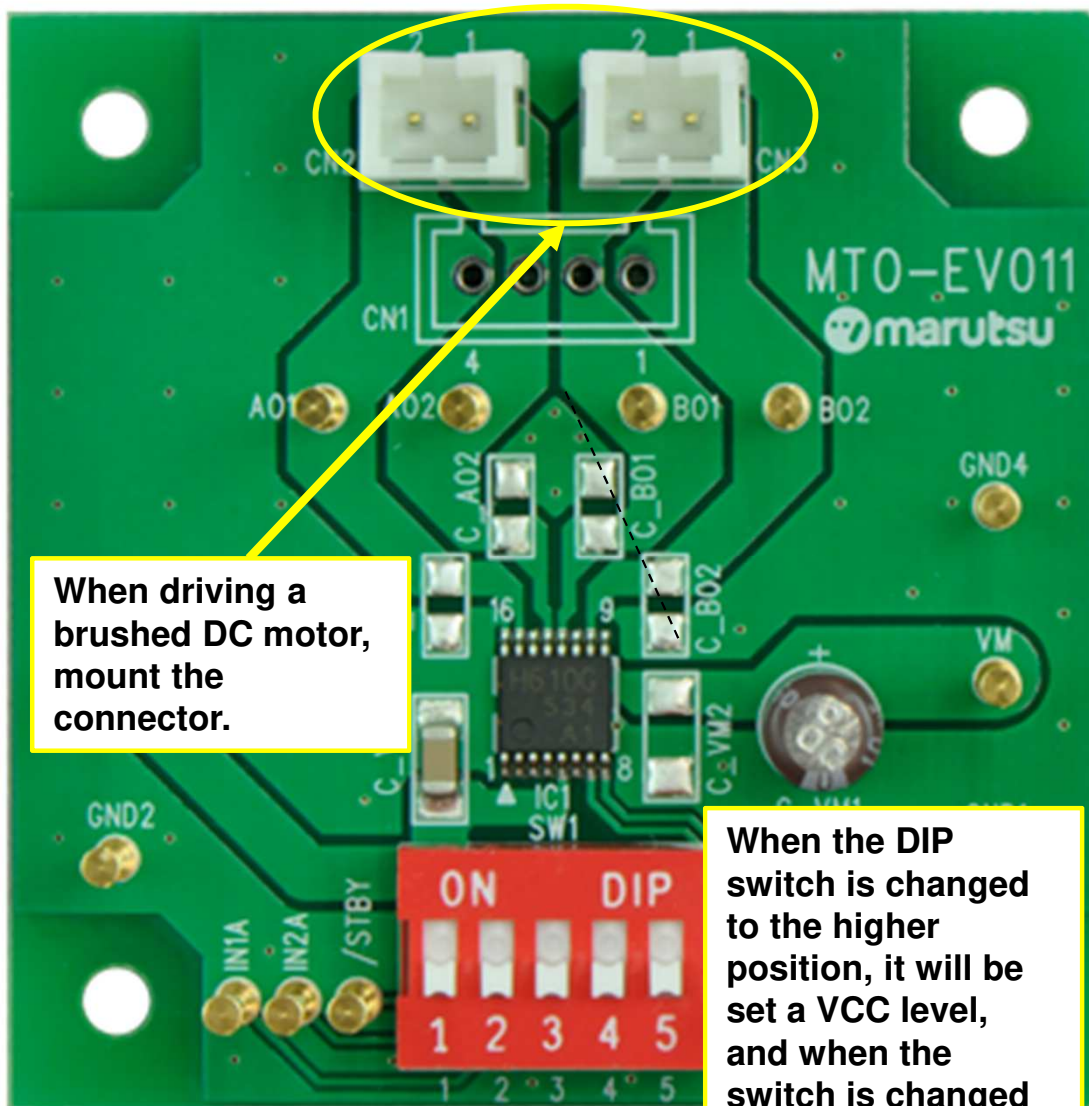

This evaluation board has a DIP switch (SW) so that the operation setting of the TC78H621FNG can be set without the external signal input.

When the DIP switch is changed to the higher position, it will be set a VCC level = "High level", and when the switch is changed to the lower position, it will be set Open.

In the case of Open, the input signal can be input from a terminal, and even if there is no input signal, the switch is fixed to "GND level" = "Low" level by the pull down resistance in the IC.

When driving a brushed DC motor, mount the connector.

When the DIP switch is changed to the higher position, it will be set a VCC level, and when the switch is changed to the lower position, it will be set Open.

Circuit of Evaluation Board

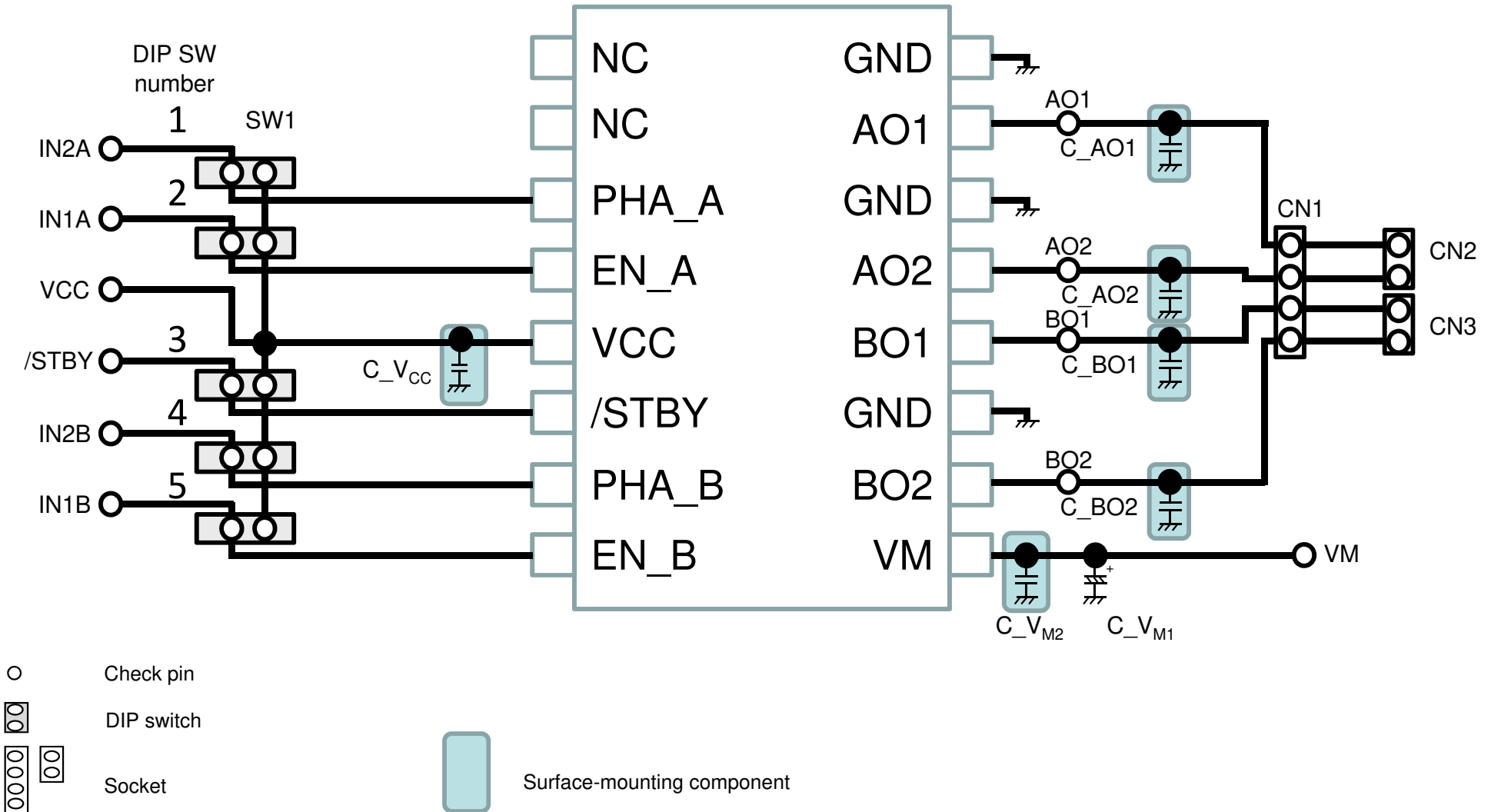

◆ Important Note ◆

● This product was not designed for use with devices which could cause personal injury in the event of failure or malfunction, including devices for use in areas including medical, military, aviation, aerospace, nuclear control, other types of safety mechanisms, etc., or for use in devices which require a high standard of safety. Do not use this product for such applications. This company assumes no liability for damages which may result from use of the product.

Manufactured and Distributed by



<https://www.marutsu.com>

Marutsuelec Co., Ltd.

5-2-2, Seiki Daiichi Building 7F, Sotokanda, Chiyoda-ku,
Tokyo 101-0021, Japan

Tel: +81-3-6803-0209 FAX: +81-3-6803-0213