

Overvoltage protected AC switch

Datasheet - production data

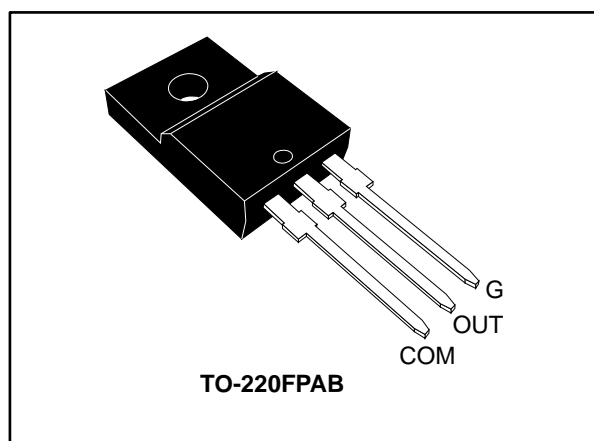

Description

This device offers a blocking voltage up to 800 V, high commutation and noise immunity, all required for inductive load control.

The thermal management in application is improved thanks to its high maximum junction temperature ($T_j = 150\text{ }^\circ\text{C}$).

It enables applications to be compliant with IEC 61000-4-4 and IEC 61000-4-5.

Figure 1: Functional diagram

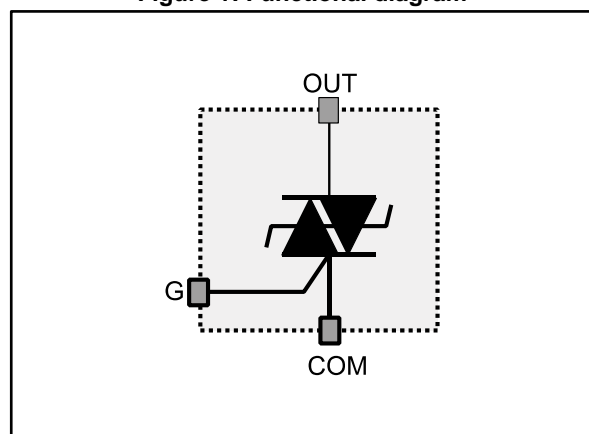

Table 1: Device summary

Order code	Package	V_{DRM}/V_{RRM}	I_{GT}
ACST1035-8FP	TO-220FPAB	800 V	35 mA

Features

- Triac with self overvoltage protection
- High static immunity and dynamic commutation
- 800 V V_{DRM}/V_{RRM}
- High junction temperature: $T_j = 150\text{ }^\circ\text{C}$
- Complies with UL standards (File ref: E81734)
- TO-220FPAB insulated package 2000 V_{RMS}
- ECOPACK[®]2 and RoHs compliant component

Applications

- Motor control for home appliance:
 - Universal drum motor of washing machine
 - Compressor of fridge or air conditioner
 - A/C compressor

1 Characteristics

Table 2: Absolute ratings (limiting values)

Symbol	Parameter		Value	Unit	
$I_{T(RMS)}$	RMS on-state current (full sine wave)		$T_c = 108\text{ °C}$	10	A
I_{TSM}	Non repetitive surge peak on-state current	$t_p = 16.7\text{ ms}$	$T_j\text{ initial} = 25\text{ °C}$	95	A
		$t_p = 20\text{ ms}$		90	
I^2t	I^2t value for fusing (full cycle sine wave)	$t_p = 10\text{ ms}$		54	A ² s
V_{RRM} / V_{DRM}	Repetitive peak off-state voltage		$T_j = 150\text{ °C}$	800	V
di/dt	Critical rate of rise of on-state current	$I_G = 2 \times I_{GT}$, $t_r \leq 100\text{ ns}$	$f = 120\text{ Hz}$, $T_j = 150\text{ °C}$	100	A/ μ s
$V_{pp}^{(1)}$	Non repetitive peak pulse line voltage		$T_j\text{ initial} = 25\text{ °C}$	2	kV
$(di/dt)_{BO}$	Non repetitive critical current rate of rise at breakover		$T_j\text{ initial} = 25\text{ °C}$	150	A/ μ s
I_{GM}	Peak gate current	$t_p = 20\text{ }\mu$ s	$T_j = 150\text{ °C}$	1	A
P_{GM}	Peak gate power			10	V
$P_{G(AV)}$	Average gate power dissipation		$T_j = 150\text{ °C}$	0.1	W
T_{stg}	Storage junction temperature range			-40 to +150	°C
T_j	Maximum operating junction temperature range			-40 to +150	°C
T_L	Maximum lead temperature for soldering during 10 s			260	°C
V_{ins}	Insulation RMS voltage (60 seconds)			2000	V

Notes:

⁽¹⁾According to test described by IEC 61000-4-5 standard and test [Fig 19](#).

Table 3: Electrical characteristics

Symbol	Test conditions		Quadrant		Value	Unit
I_{GT}	$V_D = 12\text{ V}, R_L = 33\ \Omega$	$T_j = 25\text{ }^\circ\text{C}$	I - II - III	Max.	35	mA
				Min.	1.75	
V_{GT}				Max.	1	V
V_{GD}	$V_D = V_{DRM}, R_L = 3.3\text{ k}\Omega$	$T_j = 150\text{ }^\circ\text{C}$	I - II - III	Min.	0.2	V
$I_H^{(1)}$	$I_T = 500\text{ mA}$, gate open	$T_j = 25\text{ }^\circ\text{C}$		Max.	30	mA
I_L	$I_G = 1.2 \times I_{GT}$	$T_j = 25\text{ }^\circ\text{C}$	I - II - III	Max.	40	mA
dV/dt	$V_D = 67\% V_{DRM}/V_{RRM}$, gate open	$T_j = 125\text{ }^\circ\text{C}$		Min.	4000	V/ μs
		$T_j = 150\text{ }^\circ\text{C}$		Min.	2000	
(di/dt) _c	Without snubber	$T_j = 125\text{ }^\circ\text{C}$		Min.	10	A/ms
		$T_j = 150\text{ }^\circ\text{C}$		Min.	5	
V_{CL}	$I_{CL} = 01\text{ mA}$, $t_p = 1\text{ ms}$			Min.	850	V

Notes:

⁽¹⁾For both polarities of OUT pin referenced to COM pin

Table 4: Static electrical characteristics

Symbol	Test conditions			Value	Unit
$V_{TM}^{(1)}$	$I_{TM} = 14.1\text{ A}$, $t_p = 380\ \mu\text{s}$	$T_j = 25\text{ }^\circ\text{C}$	Max.	1.5	V
V_{to}	Threshold voltage	$T_j = 150\text{ }^\circ\text{C}$	Max.	0.9	V
R_D	Dynamic resistance	$T_j = 150\text{ }^\circ\text{C}$	Max.	40	m Ω
I_{DRM}/I_{RRM}	$V_D = V_{DRM}$, $V_R = V_{RRM}$	$T_j = 25\text{ }^\circ\text{C}$	Max.	1	μA
		$T_j = 125\text{ }^\circ\text{C}$		500	
		$T_j = 150\text{ }^\circ\text{C}$		1.2	mA

Notes:

⁽¹⁾For both polarities of OUT pin referenced to COM pin

Table 5: Thermal resistance

Symbol	Parameter	Value	Unit
$R_{th(j-c)}$	Junction to case (AC)	3.5	$^\circ\text{C}/\text{W}$
$R_{th(j-a)}$	Junction to ambient (AC)	60	

1.1 Characteristics (curves)

Figure 2: Maximum power dissipation versus on-state RMS current

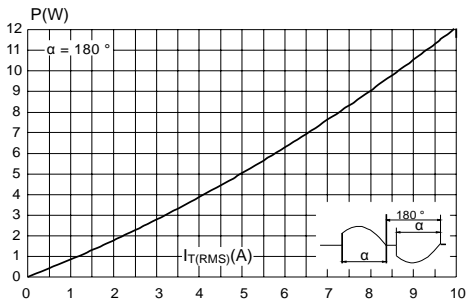

Figure 3: On-state RMS current versus temperature under tab. (full cycle)

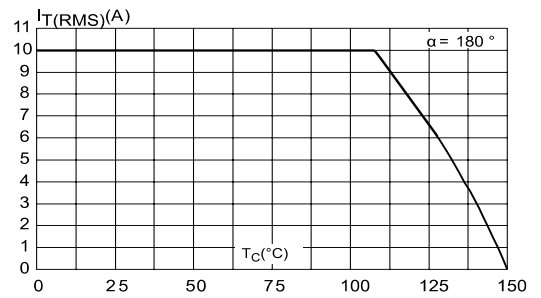

Figure 4: On state RMS current versus ambient temperature (free air convection)

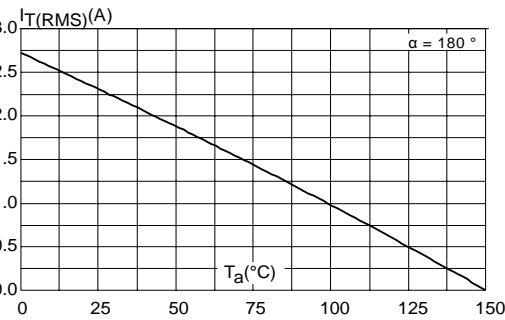

Figure 5: Relative variation of thermal impedance versus pulse duration

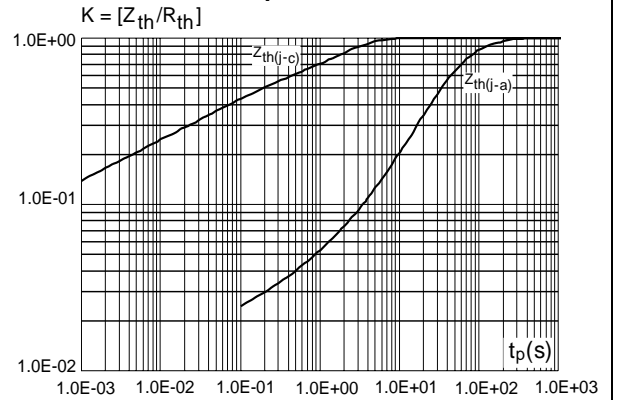

Figure 6: On-state characteristics (maximum values)

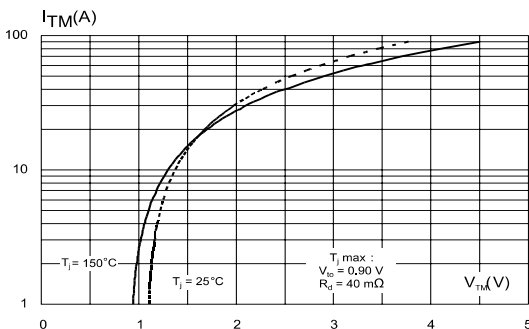

Figure 7: Surge peak on-state current versus number of cycles

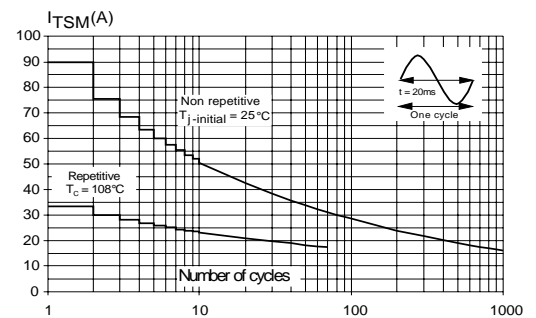

Figure 8: Non repetitive surge peak on-state current for a sinusoidal pulse with width $t_p < 10$ ms

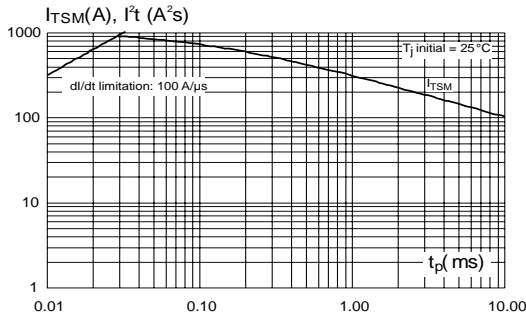

Figure 9: Relative variation of gate trigger current and gate trigger voltage versus junction temperature (typical values)

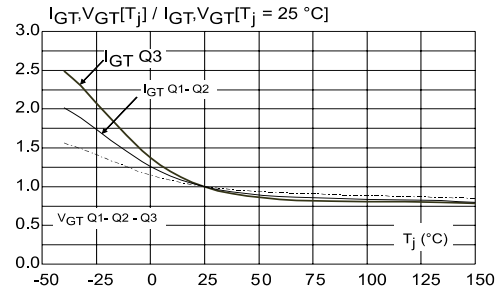

Figure 10: Relative variation of holding current and latching current versus junction temperature (typical values)

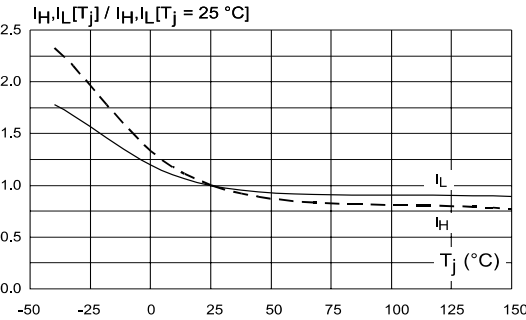

Figure 11: Relative variation of critical rate of decrease of main current (dI/dt)_c versus reappplied (dV/dt)_c

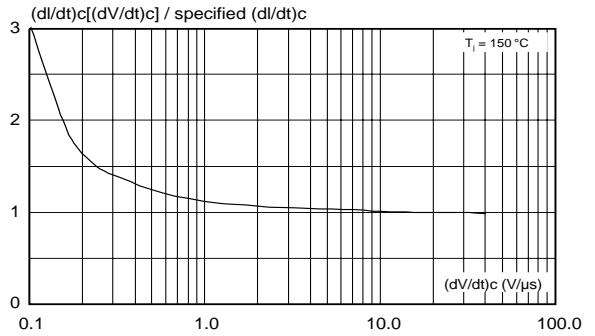

Figure 12: Relative variation of critical rate of decrease of main current versus junction temperature (typical values)

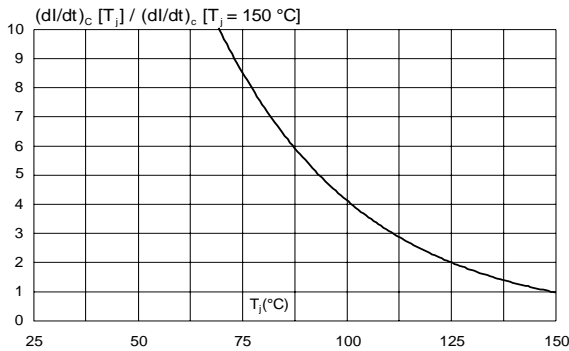

Figure 13: Relative variation of static dV/dt immunity versus junction temperature

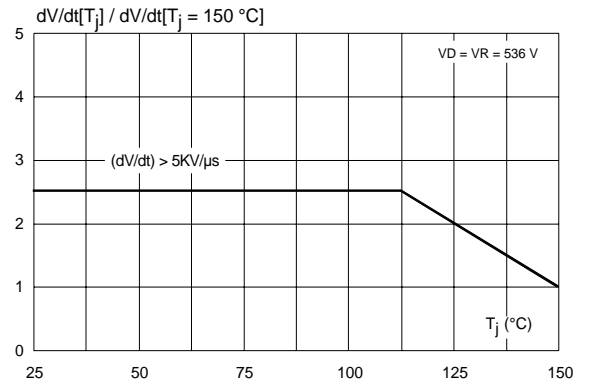

Figure 14: Relative variation of leakage current versus junction temperature for different values of blocking voltage (typical values)

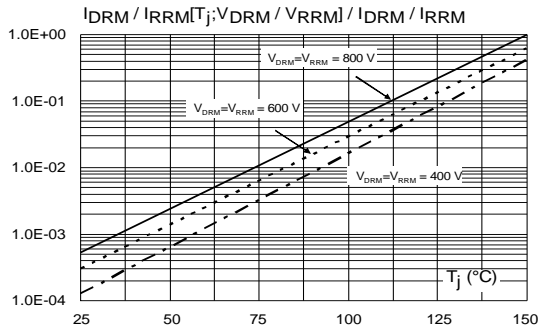
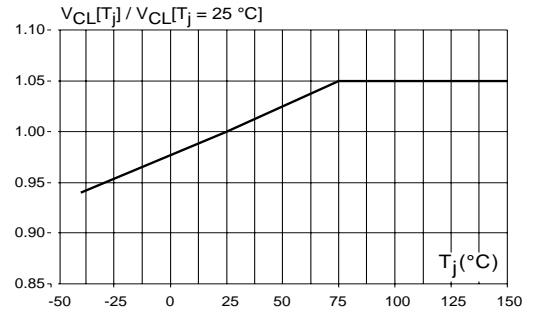

Figure 15: Relative variation of the maximum clamping voltage versus junction temperature (minimum values)



2 Application information

2.1 Typical application description

The ACST1035-8FP device has been designed to control medium power load, such as AC motors in home appliances. Thanks to its thermal and turn-off commutation performances, the ACST1035-8FP switch is able to drive an inductive load up to 10 A with no turn-off additional snubber. It also provides high thermal performances in static and transient modes such as the compressor inrush current or high torque operating conditions of an AC motor.

Figure 16: AC induction motor control - typical diagram

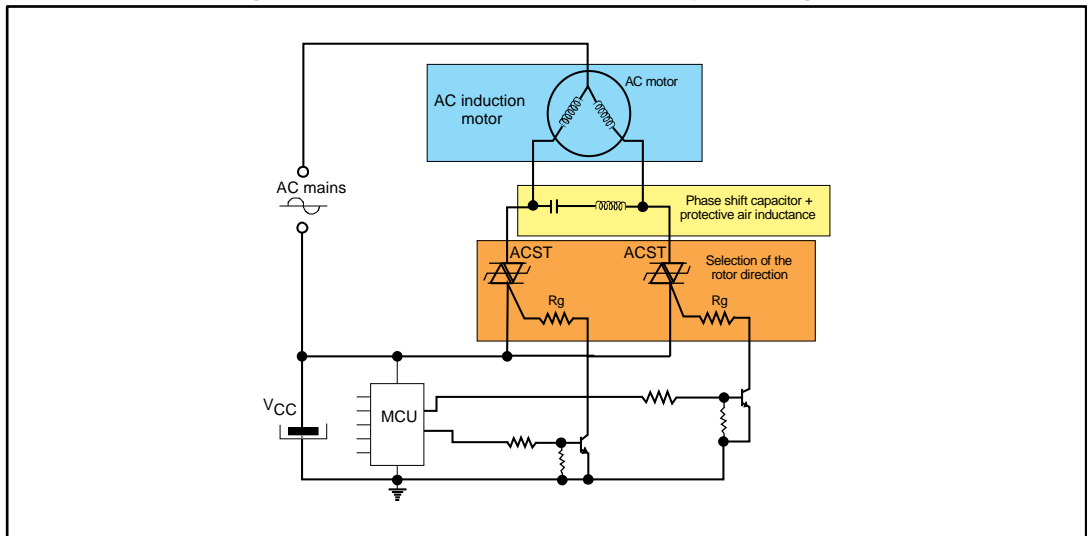
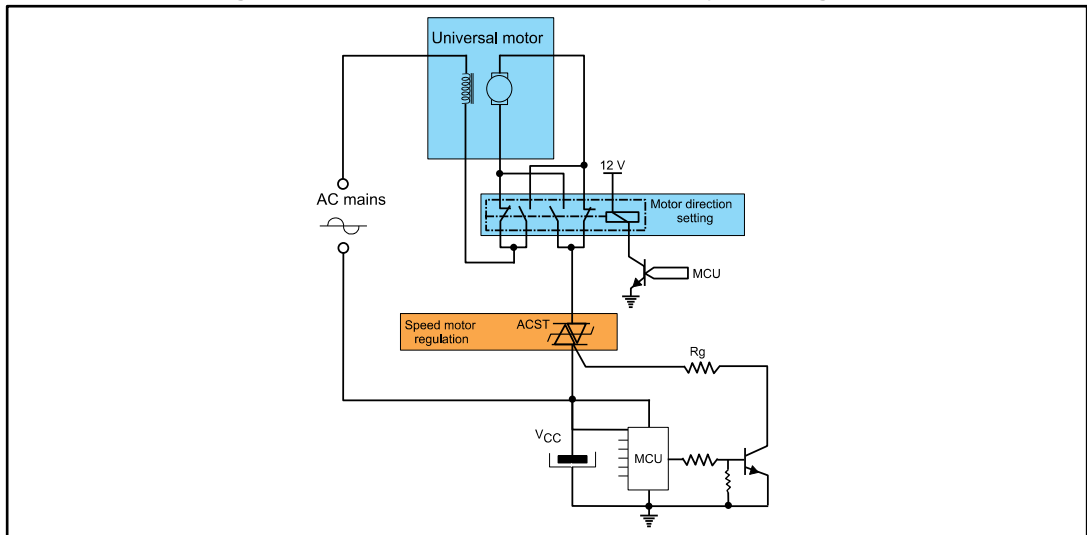
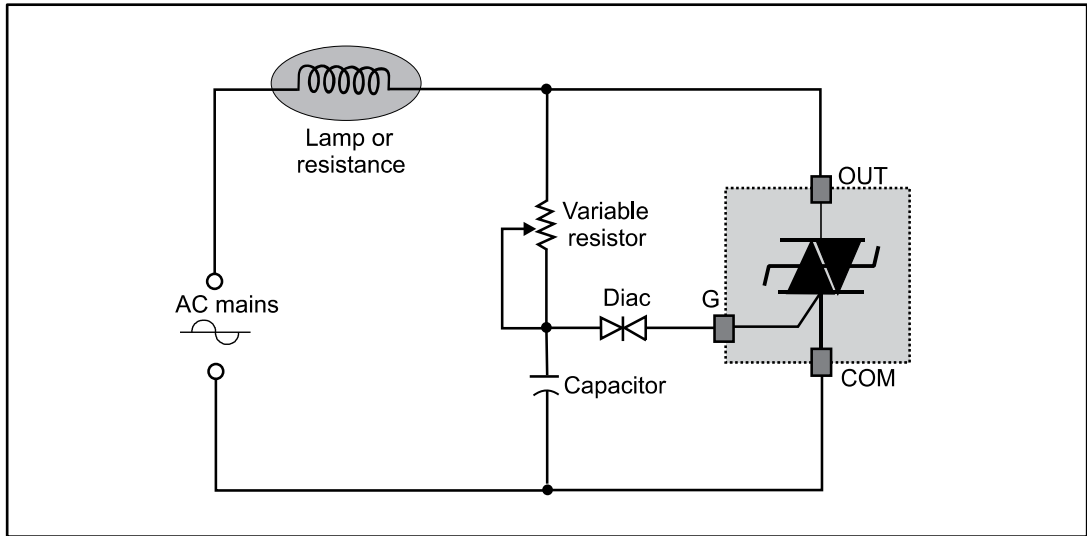

Figure 17: Universal drum motor control – typical diagram



The ACST1035-8FP device is also very effective in controlling resistive loads.

Figure 18: Resistive load control – typical diagram



2.2 AC line transient voltage ruggedness

In comparison with standard Triac, which need additional protection components against surge voltage, this device is self-protected against overvoltage, specified by the new parameter V_{CL} . Its switch can safely withstand AC line transient voltages either by clamping the low energy spikes, such as the inductive spikes at switchoff, or by switching to the on state (for less than 10 ms) to dissipate higher energy shocks through the load. This safety feature works even with high turn-on current ramp-up.

The test circuit of Figure 19 represents the ACST1035-8FP application, and is used to stress the ACST switch according to the IEC 61000-4-5 standard conditions. With the additional effect of the load which limits the current, the ACST switch withstands the voltage spikes up to 2 kV on top of the peak line voltage. The protection is based on an overvoltage crowbar technology. The ACST1035-8FP folds back safely to the on state as shown in Figure 20. The ACST1035-8FP recovers its blocking voltage capability after the surge and the next zero crossing current. Such a non repetitive test can be done at least 10 times on each AC line voltage polarity.

Figure 19: Overvoltage ruggedness test circuit for resistive and inductive loads for IEC 61000-4-5 standard)

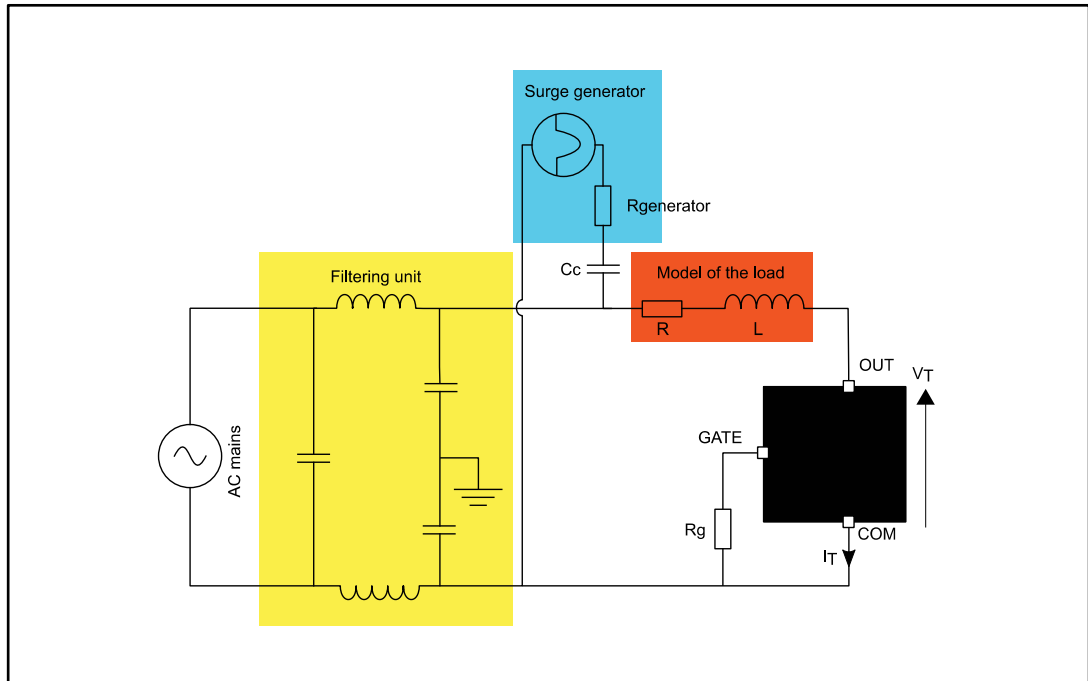

$R = 11 \Omega$, $L = 3 \mu\text{H}$, $V_{PP} = 2 \text{ kV}$, $R_g = 62 \Omega$

Figure 20: Typical voltage and current waveforms across the ACST1035-8FP during IEC 61000-4-5 standard test

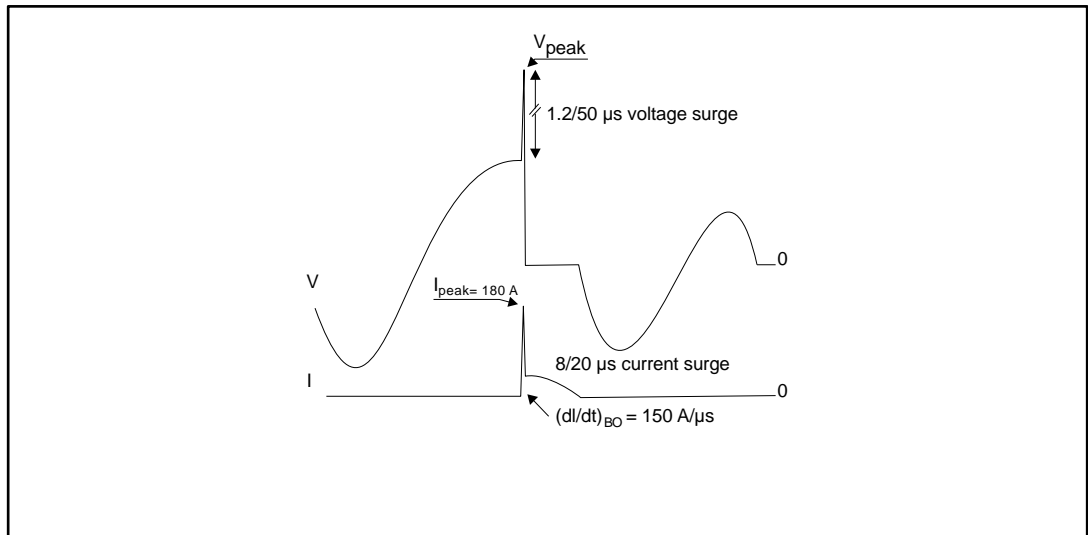

3 Package information

In order to meet environmental requirements, ST offers these devices in different grades of ECOPACK® packages, depending on their level of environmental compliance. ECOPACK® specifications, grade definitions and product status are available at: www.st.com. ECOPACK® is an ST trademark.

- Lead-free packages
- Recommended torque: 0.4 to 0.6 N·m

3.1 TO-220FPAB package information

Figure 21: TO-220FPAB package outline

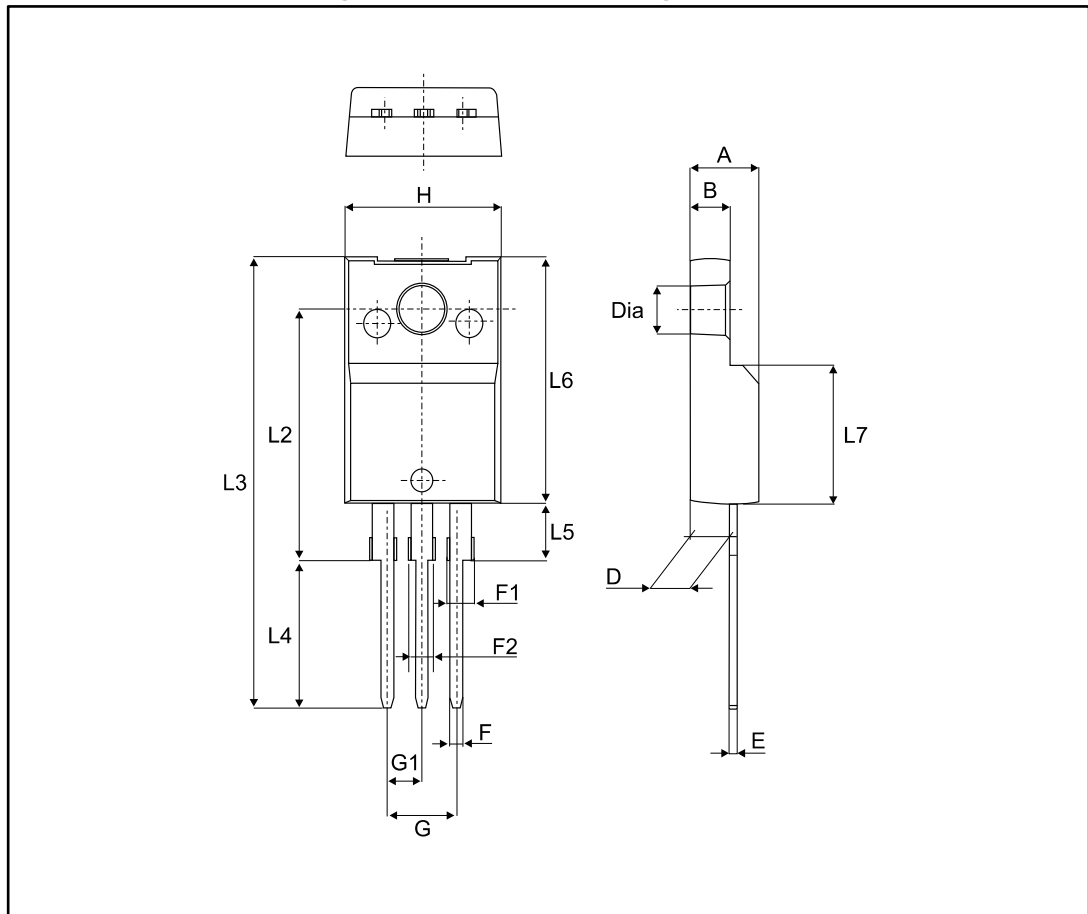

Table 6: TO-220FPAB package mechanical data

Ref.	Dimensions			
	Millimeters		Inches	
	Min.	Max.	Min.	Max.
A	4.40	4.60	0.1739	0.1818
B	2.5	2.7	0.0988	0.1067
D	2.50	2.75	0.0988	0.1087
E	0.45	0.70	0.0178	0.0277
F	0.75	1.0	0.0296	0.0395
F1	1.15	1.70	0.0455	0.0672
F2	1.15	1.70	0.0455	0.0672
G	4.95	5.20	0.1957	0.2055
G1	2.40	2.70	0.0949	0.1067
H	10.00	10.40	0.3953	0.4111
L2	16.00 typ.		0.6324 typ.	
L3	28.60	30.60	1.1304	1.2095
L4	9.80	10.6	0.3874	0.4190
L5	2.90	3.60	0.1146	0.1423
L6	15.90	16.40	0.6285	0.6482
L7	9.00	9.30	0.3557	0.3676
Dia	3.0	3.20	0.1186	0.1265

4 Ordering information

Figure 22: Ordering information scheme

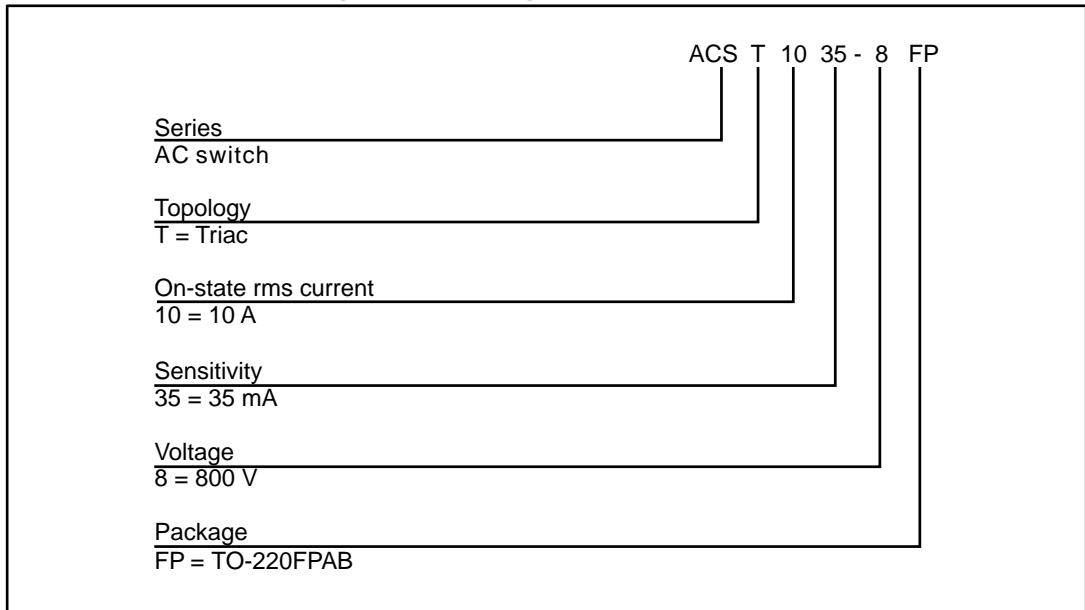

Table 7: Ordering information

Order code	Marking	Package	Weight	Base qty.	Delivery mode
ACST1035-8FP	ACST1035-8FP	TO-220FPAB	2.0 g	50	Tube

5 Revision history

Table 8: Document revision history

Date	Revision	Changes
21-Feb-2014	1	First issue.
14-Apr-2017	3	Updated Section "Features" and Table 2: "Absolute ratings (limiting values)" . Minor text changes to improve readability.

IMPORTANT NOTICE – PLEASE READ CAREFULLY

STMicroelectronics NV and its subsidiaries ("ST") reserve the right to make changes, corrections, enhancements, modifications, and improvements to ST products and/or to this document at any time without notice. Purchasers should obtain the latest relevant information on ST products before placing orders. ST products are sold pursuant to ST's terms and conditions of sale in place at the time of order acknowledgement.

Purchasers are solely responsible for the choice, selection, and use of ST products and ST assumes no liability for application assistance or the design of Purchasers' products.

No license, express or implied, to any intellectual property right is granted by ST herein.

Resale of ST products with provisions different from the information set forth herein shall void any warranty granted by ST for such product.

ST and the ST logo are trademarks of ST. All other product or service names are the property of their respective owners.

Information in this document supersedes and replaces information previously supplied in any prior versions of this document.

© 2017 STMicroelectronics – All rights reserved