

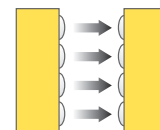

LS10 Light Screen System

- Emitter and receiver pair produce a strobed array of modulated light beams to produce a light screen
- Simple, economical and highly reliable means of sensing small parts which pass anywhere through the light screen
- Light screen area measures 90 mm (3.5") high, and as wide as the distance between the emitter and receiver
- Fast, 1 millisecond response; output includes a 5-millisecond pulse stretcher for interfacing reliability
- Tight beam spacing for sensing small parts as small as 5.6 mm (0.22") diameter
- Totally self-contained; very rugged with totally encapsulated circuitry
- Bipolar design offers the choice of NPN (current sinking) or PNP (current sourcing) outputs from the same receiver; both outputs may be used simultaneously

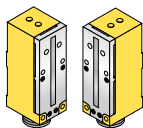

Infrared, 880 nm

LS10 Series Opposed Mode Emitter (E) and Receiver (R)

Models	Range	Cable*	Supply Voltage	Output Type	Minimum Resolution
LS10ESR	100 to 200 mm (4" to 8")	3-Pin Mini-style QD	12-30V DC	Bipolar NPN/PNP DO	5.6 mm (0.22")
LS10RSR		4-Pin Mini-style QD			
LS10E	100 to 1220 mm (4" to 48")	3-Pin Mini-style QD			7.6 mm (0.30")
LS10R		4-Pin Mini-style QD			

*Emitters come with a 3-pin Mini-style connector; receivers come with a 4-pin connector. All require a mating cable; see page 5.



WARNING . . . Not To Be Used for Personnel Protection

Never use these products as sensing devices for personnel protection. Doing so could lead to serious injury or death.

These sensors do NOT include the self-checking redundant circuitry necessary to allow their use in personnel safety applications. A sensor failure or malfunction can cause either an energized or de-energized sensor output condition. Consult your current Banner Safety Products catalog for safety products which meet OSHA, ANSI and IEC standards for personnel protection.

MULTI-BEAM[®] LS10 Light Screen System

LS10 System Overview

LS10 Light Screen Systems consist of two self-contained units: an emitter and a receiver. Multiple infrared LEDs in the emitter are aligned in a row and strobed (turned ON one at a time) in a specific sequence and at a high frequency. Receivers contain a matching array of phototransistors. The length (height) of the array is 90 mm (3.5"), and produces a curtain of light as wide as the distance between the emitter and receiver. The receiver may be placed 4" to 48" opposed from the emitter (LS10E/LS10R) or 4" to 8" away (LS10ESR/LS10RSR). The LS10E/LS10R system can detect objects as small as 7.6 mm (0.30") in diameter; minimum detectable object profile for the LS10ESR/LS10RSR system is 5.6 mm (0.22").

NOTE: Sensing should not take place within 1/2" of any LS10 system sensor face.

The light from the emitter is modulated to minimize sensitivity to ambient light. An indicator LED on the emitter lights whenever power is applied. The receiver has an Alignment LED which lights whenever the beam is broken.

The receiver output interfaces directly with dc loads or circuits up to 30V dc, and offers both sinking (NPN) and sourcing (PNP) output transistors. The sinking (NPN) output may be connected directly to any Banner MAXI-AMP or MICRO-AMP logic module for additional system control. Outputs are energized continuously while the beam is broken. A 5 millisecond pulse stretcher (OFF delay) is included to improve interfacing reliability.

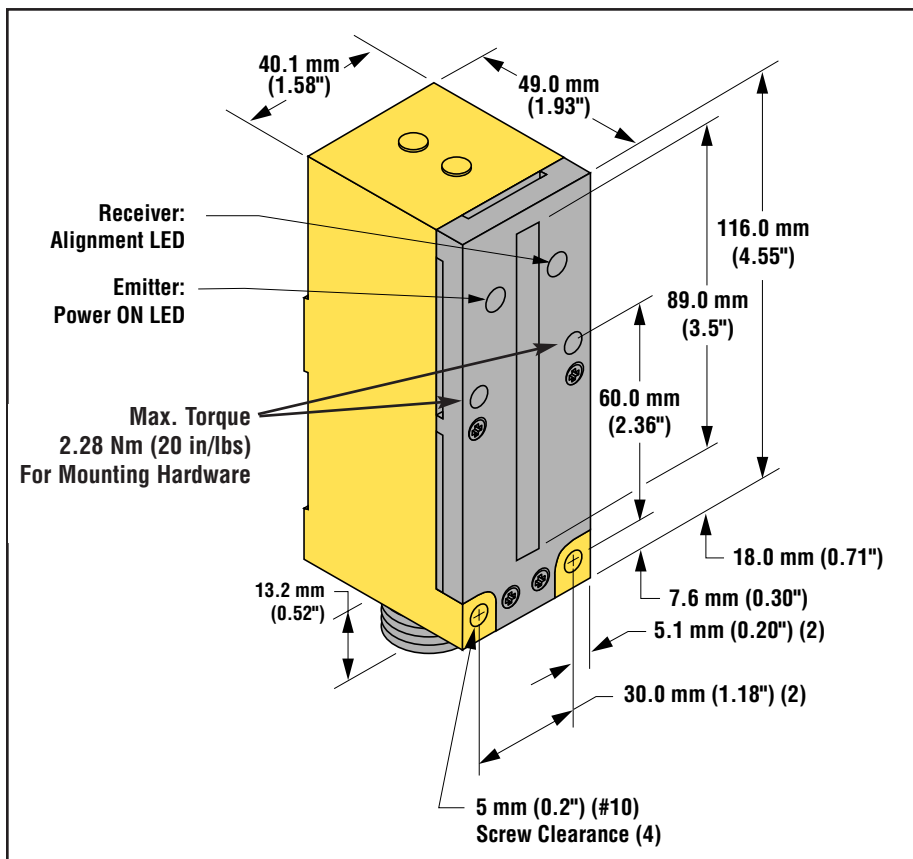

Figure 1. LS10 features

Installation and Alignment

The reliable performance of light screen systems requires careful alignment and secure mounting. The 2-part, 3-axis mounting brackets on page 5 are highly recommended. Mounting locations should be as free from vibration as possible. If vibration is unavoidable, mount the emitter and receiver to vibrate together; no high-amplitude differential vibration is allowed.

Mount the emitter and receiver at their operating locations with their front panels exactly parallel and opposite each other. (The row of transmitter LEDs should be exactly parallel with and opposite to the row of receiver phototransistors.) This constitutes optimal mechanical alignment.

Optimal mechanical alignment does not always result in perfect optical alignment, and perfect optical alignment is absolutely necessary. When optical alignment is satisfactory, and emitter/receiver vibration is at moderate or lower levels, the receiver Alignment status indicator (see Figure 1) will be OFF and remain OFF whenever the light screen is unobstructed.

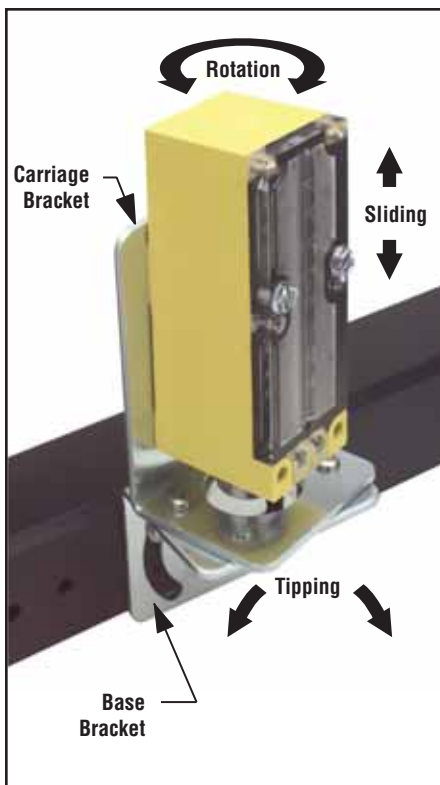

Figure 2. Achieving perfect optical alignment with the LS10; bracket SMBLS shown.

Adjusting Optical Alignment

Beginning with perfect mechanical alignment, adjust optical alignment as described in steps #1 through #5. The procedure assumes use of the SMBLS mounting bracket shown in Figure 2. Only the position of the emitter will be adjusted.

- 1) Loosen the two bolts holding the two parts of the bracket together just enough to allow the upper (“carriage”) bracket, along with the emitter, to be rotated. Also, slightly loosen the mounting bolts in the curved slots of the “base” bracket, which will allow the bracket to be tipped from side to side.
- 2) With power applied to both the emitter and receiver, “tip” the entire bracket (including the emitter) slightly from side to side. Find the extremes of movement between which the receiver’s red Alignment LED remains OFF. Secure the base bracket at the point midway between the extremes.
- 3) Rotate the carriage bracket (to which the emitter is attached) slightly in both directions, as shown in Figure 2. Find the extremes of rotation between which the receiver’s red Alignment indicator LED remains OFF. Secure the emitter midway between the extremes by tightening the two bolts that lock the two parts of the bracket together.
- 4) Loosen the two mounting bolts that hold the emitter to the carriage bracket. Slide the emitter up and down vertically in the bracket, noting the extremes between which the receiver’s Alignment LED indicator remains OFF. Tighten the bolts to secure the emitter midway between the extremes. (NOTE: If the initial mechanical alignment was inadequate, it may be necessary to repeatedly alternate tipping, rotating, and sliding movements to attain perfect optical alignment.)
- 5) Check for proper alignment by moving a pencil (or a similar object) along the 3.5” dimension of the sensing window. The receiver Alignment indicator LED and outputs should come ON while the pencil is anywhere within the sensing window. When this is true, tighten all mounting hardware securely in position.

MULTI-BEAM[®] LS10 Light Screen System

LS10 Series Specifications

Supply Voltage and Current	12 to 30V dc (10% maximum ripple) at less than 70 mA (emitter) or 45 mA (receiver – exclusive of load)
Supply Protection Circuitry	Protected against reverse polarity
Output Configuration	Bipolar: One current sourcing (PNP) and one current sinking (NPN) open-collector transistor
Output Rating	125 mA maximum each output Off-state leakage current: less than 1 microamp Output saturation voltage (PNP output): < 1 volt at 10 mA and < 2 volts at 150 mA Output saturation voltage (NPN output): < 200 millivolts at 10 mA and < 1 volt at 150 mA
Output Protection Circuitry	Protected against false pulse on power-up and continuous overload or short circuit of outputs
Output Response Time	Receiver will respond to a “dark” signal of 1 millisecond or longer duration; a 5-millisecond pulse stretcher (OFF Delay) is included to improve interfacing reliability; successive parts must have at least 10 millisecond separation
Repeatability	30 microseconds (light-to-dark)
Resolution	5.6 mm (0.22") or 7.6 mm (0.30"), depending on model
Indicators	Power (emitter only): lights whenever power is applied Alignment (receiver only): lights whenever light screen is interrupted
Construction	Reinforced thermoplastic polyester housing, acrylic lenses, and stainless steel hardware
Environmental Rating	Meets NEMA standards 1, 2, 3, 12, and 13; IEC IP54
Connections	See product selection tables
Operating Conditions	Temperature: 0° to +50°C (+32° to 122°F) Maximum relative humidity: 90% at 50°C (non-condensing)
Application Notes	i) The best sensing resolution occurs near the center of the sensing area, midway between the emitter and receiver. ii) Outputs are energized continuously while the light screen is interrupted.
Certifications	

LS10 Series Hookups

**LS10 Emitters with Quick-Disconnect
(3-Pin Mini-Style)**

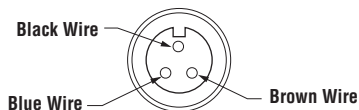
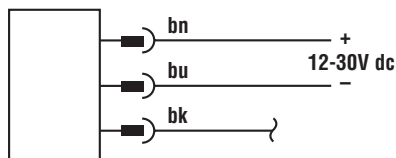

**LS10 Receivers with Quick-Disconnect
(4-Pin Mini-Style)**

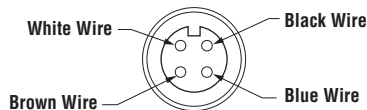
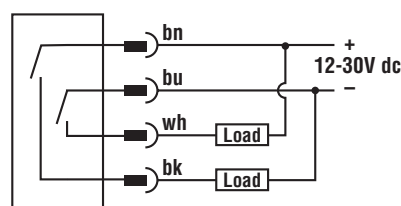

MULTI-BEAM® LS10 Light Screen System

Accessories

Replacement Lens Assemblies

LS Series lens assemblies are field-replaceable.

Model	Description
UC-LS10 UC-LS10SR	Replacement lens for LS10E and LS10R Replacement lens for LS10ESR and LS10RSR

Quick-Disconnect (QD) Cables

Style	Model	Length	Connector	Used with:
3-Pin Mini	MBCC-306	2 m (6.5')	Straight	LS10 Series Emitters
	MBCC-312	4 m (12')		
	MBCC-330	9 m (30')		
4-Pin Mini	MBCC-406	2 m (6.5')	Straight	LS10 Series Receivers
	MBCC-412	4 m (12')		
	MBCC-430	9 m (30')		

Mounting Brackets

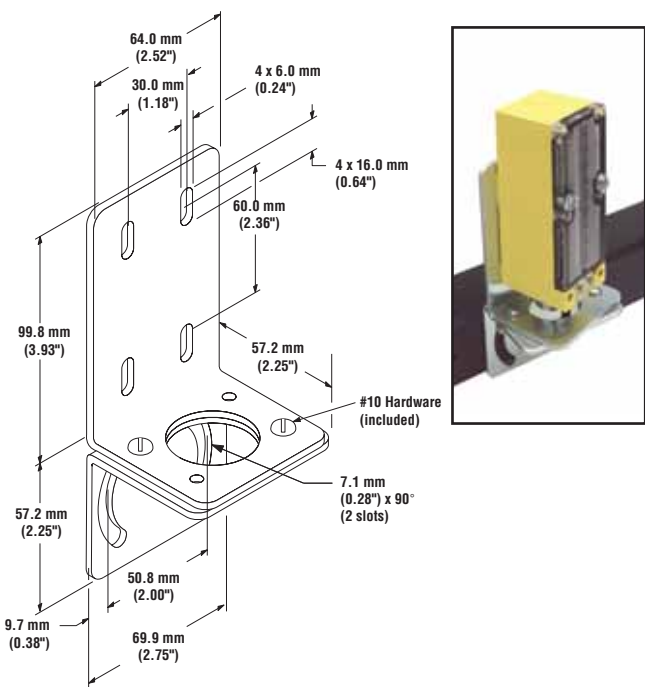
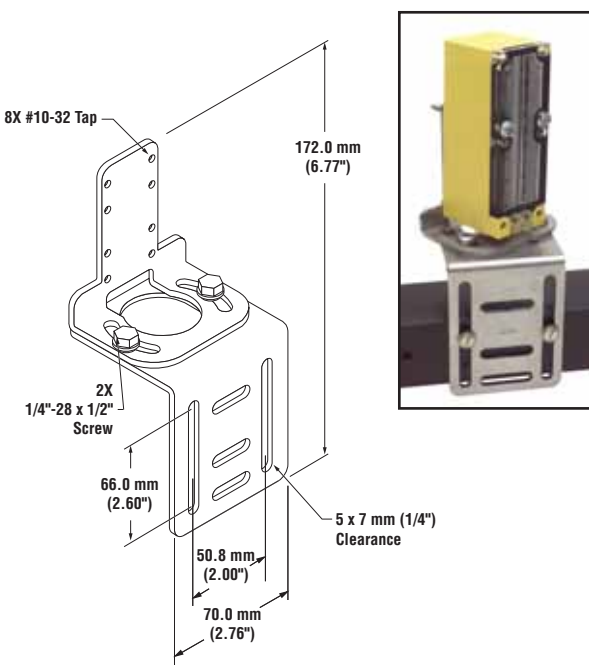
<p>SMBLS</p>	<ul style="list-style-type: none"> • Two 11-gauge zinc plated steel, right angle brackets fasten together to they can rotate relative to each other • Assembly hardware and cable gland are included 	<p>SMB30UR</p>	<ul style="list-style-type: none"> • 2-piece universal swivel bracket for limit-switch style sensors • 300 series stainless steel • Includes stainless steel swivel locking hardware
 <p>Technical drawing of SMBLS mounting bracket showing dimensions: 64.0 mm (2.52"), 30.0 mm (1.18"), 4 x 6.0 mm (0.24"), 4 x 16.0 mm (0.64"), 60.0 mm (2.36"), 99.8 mm (3.93"), 57.2 mm (2.25"), 7.1 mm (0.28") x 90° (2 slots), 50.8 mm (2.00"), 9.7 mm (0.38"), 69.9 mm (2.75"). Includes #10 Hardware (included).</p>		 <p>Technical drawing of SMB30UR mounting bracket showing dimensions: 172.0 mm (6.77"), 8X #10-32 Tap, 1/4"-28 x 1/2" 2X Screw, 66.0 mm (2.60"), 50.8 mm (2.00"), 70.0 mm (2.76"), 5 x 7 mm (1/4") Clearance.</p>	

MULTI-BEAM[®] LS10 Light Screen System



WARRANTY: Banner Engineering Corp. warrants its products to be free from defects for one year. Banner Engineering Corp. will repair or replace, free of charge, any product of its manufacture found to be defective at the time it is returned to the factory during the warranty period. This warranty does not cover damage or liability for the improper application of Banner products. This warranty is in lieu of any other warranty either expressed or implied.