

- 1
- 2
- 3
- 4
- 5
- 6
- 7
- 8
- 9
- 10
- 11
- 12
- 13
- 14
- 15
- 16
- 17
- 18

**MATERIAL**

Glass-fibre reinforced polyamide based (PA) technopolymer, black colour, matte finish.

**SELF-ADHESIVE FRONT PLATE**

Anodised aluminium.

**STANDARD EXECUTIONS**

- **MT.**: with revolving handle l.780+x (see page -) in technopolymer. Black-oxide steel hub, H9 blind hole or H7 reamed pass-through hole.
- **MT-AS**: with revolving handle l.780+x (see page -) in technopolymer. Black-oxide steel boss with H9 square pass-through hole.
- MT.50-AS H9 square pass-through hole with brass reinforcement.
- **MT+HR**: with fold-away handle IR.780 (see page -). Black-oxide steel hub, H9 blind hole or H7 reamed pass-through hole.

**FEATURES AND APPLICATIONS**

The reticular structure of the crank arm and the technopolymer used make this handle very strong and therefore suitable for transmitting high torque values.

**ACCESSORIES ON REQUEST**

Axial retaining washer GN 184 (see page 677).



ELESA Original design design80

Conversion Table 1 mm = 0.039 inch	
R	
mm	inch
50	1.95
64	2.50
80	3.12
100	3.90
130	5.07
160	6.24
210	8.19

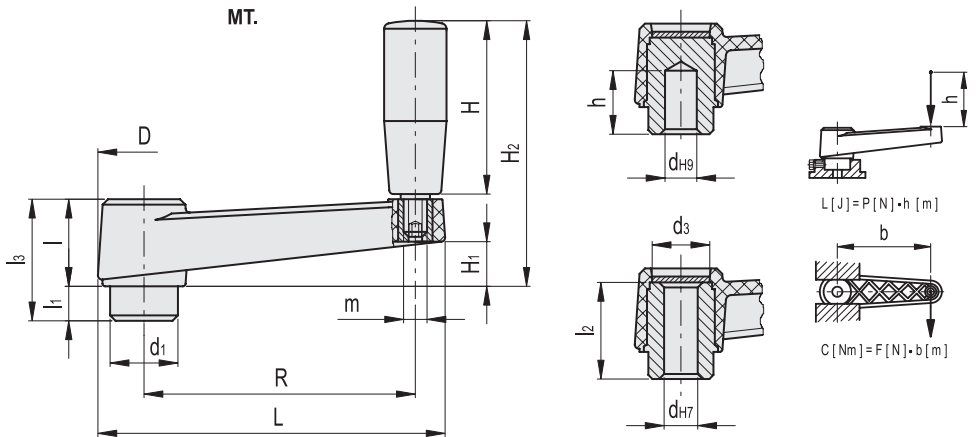

**MT.**

**METRIC**

Code	Description	R	dH7	dH9	L	D	d1	d3	l	l1	l2	l3	h	H	H1	H2	m	C# [Nm]	L# [J]	Δ
44051	MT.50 A-6	50	6	-	69	23	16	13	21	10	28	31	-	28	10	49	-	60	7	65
44091	MT.64	64	-	6	86	27	18	16	23	10	29	33	18	40	10	63	M6	120	11	100
44101	MT.64 A-8	64	8	-	86	27	18	16	23	10	29	33	-	40	10	63	M6	120	11	95
44102	MT.64-A10	64	10	-	86	27	18	16	23	10	29	33	-	40	10	63	M6	120	11	93
44191	MT.80	80	-	6	105	30	22	17	26	10	32	36	26	50	13	76	M6	180	15	145
44201	MT.80 A-10	80	10	-	105	30	22	17	26	10	32	36	-	50	13	76	M6	180	15	130
44291	MT.100	100	-	8	128	34	24	21	30	10	37	40	28	65	15	96	M8	200	27	240
44301	MT.100 A-12	100	12	-	128	34	24	21	30	10	37	40	-	65	15	96	M8	200	27	225
44391	MT.130	130	-	10	162	40	28	25	35	14	44	49	30	80	20	115	M8	350	45	345
44401	MT.130 A-14	130	14	-	162	40	28	25	35	14	44	49	-	80	20	115	M8	350	45	310
44491	MT.160	160	-	10	198	45	34	27	40	15	49	55	30	90	23	130	M10	450	55	495
44501	MT.160 A-16	160	16	-	198	45	34	27	40	15	49	55	-	90	23	130	M10	450	55	435
44601	MT.210	212	-	12	252	50	40	31	45	15	53	60	30	90	26	136	M10	950	80	705

Handwheels and crank handles

# For maximum applicable torque (C) and impact strength (L) see Technical data on page A-3.

Conversion Table	
1 mm = 0.039 inch	
R	
mm	inch
50	1.95
64	2.50
80	3.12
100	3.90
130	5.07
160	6.24
212	8.27

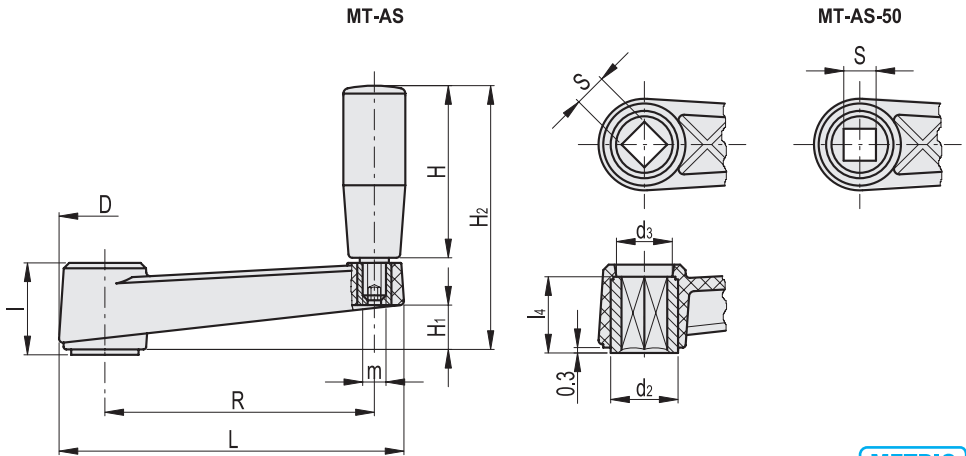

MT-AS

METRIC

Code	Description	R	SH9	L	D	d2	d3	l	l4	H	H1	H2	m	C# [Nm]	L# [J]	⚖
44052	MT.50 AS-6x6	50	6	69	23	-	13	21	18	28	10	49	-	60	7	35
44111	MT.64 AS-8x8	64	8	86	27	18	16	23	19	40	10	63	M6	120	11	78
44211	MT.80 AS-10x10	80	10	105	30	20	17	26	22	50	13	76	M6	180	15	105
44311	MT.100 AS-12x12	100	12	128	34	25	21	30	27	65	15	96	M8	200	27	190
44411	MT.130 AS-14x14	130	14	162	40	28	25	35	30	80	20	115	M8	350	45	255
44511	MT.160 AS-17x17	160	17	198	45	30	27	40	34	90	23	130	M10	450	55	335

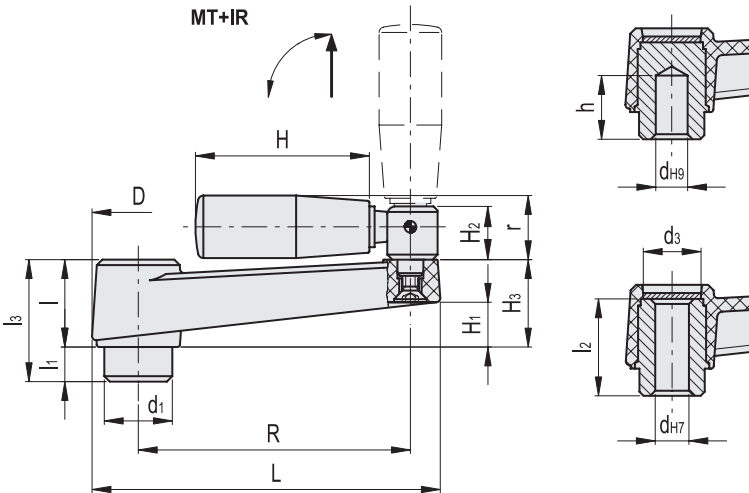

MT+IR

METRIC

Code	Description	R	dH7	dH9	L	D	d1	d3	l	l1	l2	l3	h	H	H1	H2	H3	r	C# [Nm]	L# [J]	⚖
44216	MT.80+IR	80	-	6	105	30	22	17	26	10	32	36	26	56	13	15	27	19	180	15	177
44221	MT.80+IRA-10	80	10	-	105	30	22	17	26	10	32	36	-	56	13	15	27	19	180	15	163
44316	MT.100+IR	100	-	8	128	34	24	21	30	10	37	40	28	65	15	20	31	22	200	27	285
44321	MT.100+IRA-12	100	12	-	128	34	24	21	30	10	37	40	-	65	15	20	31	22	200	27	265
44416	MT.130+IR	130	-	10	162	40	28	25	35	14	44	49	30	65	20	20	35	22	350	45	385
44421	MT.130+IRA-14	130	14	-	162	40	28	25	35	14	44	49	-	65	20	20	35	22	350	45	340
44516	MT.160+IR	160	-	10	198	45	34	27	40	15	49	55	30	80	23	20	40	24	450	55	525
44521	MT.160+IRA-16	160	16	-	198	45	34	27	40	15	49	55	-	80	23	20	40	24	450	55	473
44621	MT.210+IR	212	-	12	252	50	40	31	45	15	53	60	30	90	26	23	46	27	950	80	840

# For maximum applicable torque (C) and impact strength (L) see Technical data on page A-3.