

SST-10-UV

Surface Mount UV LED

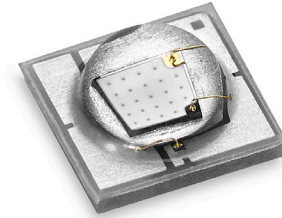

Table of Contents

Binning Structure	2
Ordering Information	3
Ordering Bin Kits	3
Optical & Electrical Characteristics	4
Typical Spectrum	6
Radiation Pattern	6
Thermal Resistance	7
Mechanical Dimensions	8
Tape and Reel Outline	9
Soldering Profile	10
Packaging and shipping specifications	11
Revision History	12

Features:

- High Power UV LED with peak wavelengths 365 nm, 385 nm, 395 nm and 405 nm
- Industry standard 3.5 mm x 3.5 mm package
- 130° viewing angle
- Low Thermal Resistance : 1.4 °C/W
- Built-in ESD Protection
- Environmentally friendly: REACH, RoHS and Halogen compliant

Applications:

-
- Curing- inks, coating and adhesives
 - Photocatalytic air/water purification
 - Medical and Analytic instrumentation
 - Diagnostics
 - Fluorescence Imaging

Binning Structure

SST-10-UV LEDs are specified for flux peak wavelength and voltage at a drive current of 500 mA with a 20 ms pulse at 25°C and placed into one of the following Flux, Peak Wavelength and Forward Voltage Bins.

Flux Bins¹

Color	Power Flux Bin (F)	Minimum Flux (mW)	Maximum Flux (mW)
UV	E	720	810
	F	810	900
	G	900	990
	H	990	1080
	I	1080	1170
	J	1170	1260
	K	1260	1350

Note 1: Luminus maintains a +/- 6% tolerance on power measurements.

Peak Wavelength Bins

Color	Wavelength Bin (WWW)	Minimum Wavelength (nm)	Maximum Wavelength (nm)
UV	365	365	370
	370	370	375
	380	380	385
	385	385	390
	390	390	395
	395	395	400
	400	400	405
	405	405	410

Forward Voltage Bins

Color	Vf Bin Code	Minimum Vf (V)	Maximum Vf (V)
UV	V1	3.0	3.2
	V2	3.2	3.4
	V3	3.4	3.6
	V4	3.6	3.8
	V5	3.8	4.0

Ordering Information

Products	Ordering Part Number	Description
SST-10-UV	SST-10-UV-X130-FWWW-00	UV LED in a 3535 surface mount package with a 130 degree molded lens

Part Number Nomenclature

SST — 10 — UV — X130 — FWWW-00

Product Family	Chip Area	Color	Package Configuration ²	Bin Kit ^{3,4}
SST: Surface Mount package	10: 1 mm ²	UV = Ultraviolet	A130 : "A" solder pad layout and 130 ° lens B130 : "B" solder pad layout and 130 ° lens	See ordering bin kits table below for complete bin definition

Note 2: Refer to drawings on page 9 for details on "A" and "B" solder pad layouts

Note 3: A Bin Kit represents a group of flux and wavelength bins that are shippable for a given ordering part number. Individual bins are not orderable..

Note 4: Flux Bin listed is minimum bin shipped - higher bins may be included at Luminus' discretion

Ordering Bin Kits

Wavelength Range (nm)	Luminous Flux		Wavelength Bins	Ordering Bin Kit Number
	Bin Kit Flux Code	Min. Flux (mW)		
365-375	F	810	365, 370	F365-00
	G	900	365, 370	G365-00
380-390	G	900	380, 385	G385-00
	H	990	380, 385	H385-00
390-400	G	900	390, 395	G395-00
	H	990	390, 395	H395-00
400-410	G	900	400,405	G405-00

Optical & Electrical Characteristics ($T_{hs} = 25^{\circ}\text{C}$)

UV						
Parameter	Symbol	Values ⁵				Unit
Peak Wavelength Range	λ	365-375	380-390	390-400	400-410	nm
Test Current for binning ⁶	I	500	500	500	500	mA
Peak Wavelength Typ.	λ_p	370	385	395	405	nm
Forward Voltage	$V_{F\ min}$	3.0	3.0	3.0	3.0	V
	V_F	3.7	3.4	3.3	3.3	V
	$V_{F\ max}$	4.0	4.0	4.0	4.0	V
Radiometric Flux ⁷	Φ_{typ}	875	1015	1015	930	mW
FWHM at 50% of Φ	$\Delta\lambda_{1/2}$	10	10	10	10	nm
Viewing Angle	$2\Phi_{1/2}$	130	130	130	130	degrees

Parameter	Symbol	Values
Absolute Maximum Current (CW) ⁸	I_{max}	365 nm- 1A 385-405 nm- 1.5 A
Maximum Junction Temperature ⁸	T_{cmax}	100 °C
Storage Temperature Range	T_s	-40 to +100 °C
Soldering Temperature	T_{SLD}	245 °C
ESD Sensitivity (HBM)	V_B	6000 V

Note 5: Unless otherwise noted, values listed are typical. Devices are production tested and specified at 500 mA with a 20 ms pulse at 25°C.

Note 6: While SST-10-UV devices are tested at 500 mA, they can be driven at CW currents ranging from 200 mA to 1.5 A and at duty cycles ranging from 1% to 100%. Drive current and duty cycle should be adjusted as necessary to maintain the junction temperature desired to meet application lifetime requirements.

Note 7: Typical radiometric flux is for reference only. Minimum flux values are guaranteed based on the bin kit ordered. For product roadmap and future performance of devices, contact Luminus.

Note 8: SST-10-UV LEDs are designed for operation to an absolute maximum current as specified above. Product lifetime data is specified at or below maximum drive current. Sustained operation beyond absolute maximum currents will result in a reduction of device life time. Actual device lifetimes will also depend on junction temperature and operation beyond maximum junction temperature is not recommended. Contact Luminus for lifetime derating curves and for further information. In pulsed operation, rise time from 10-90% of forward current should be longer than 0.5 μseconds.

Optical & Electrical Characteristics

Relative Power vs. Forward Current

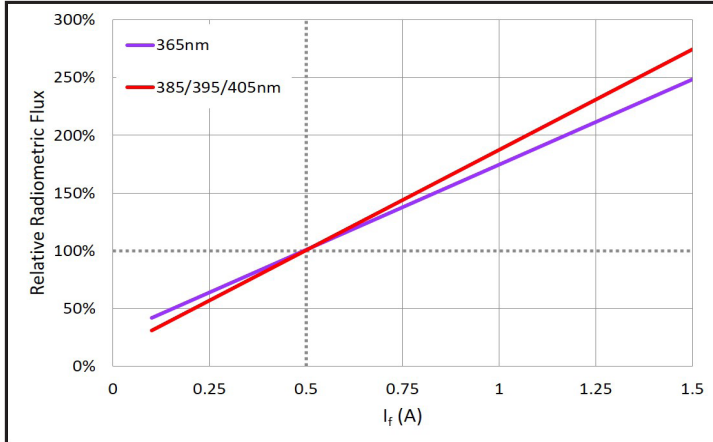
 $\phi/\phi_{(500\text{ mA})}$, 20 ms pulse, $T_c = 25^\circ\text{C}$

Relative Power vs. Junction Temperature

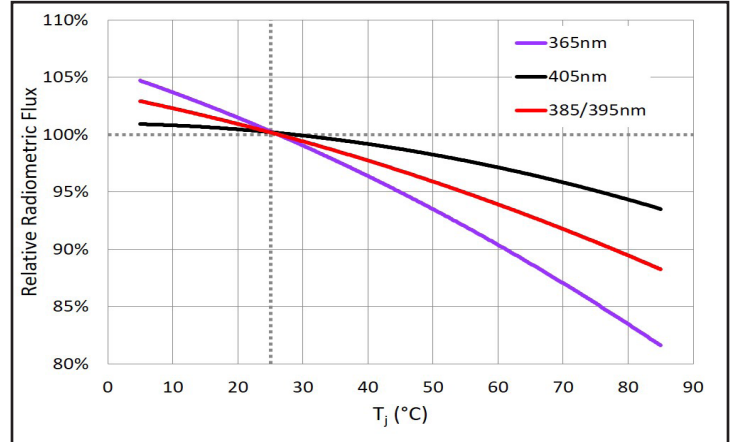
 $\phi/\phi_{(25^\circ\text{C})}$, 20 ms pulse, 500 mA

Peak Wavelength Shift vs. Forward Current

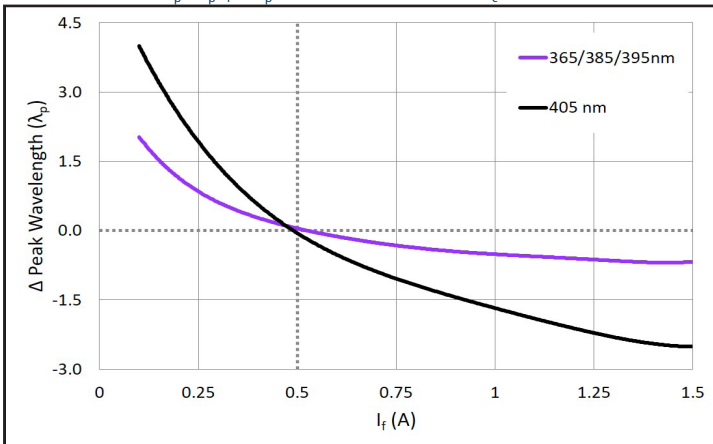
 $\lambda_p = \lambda_p(I_f) - \lambda_p(500\text{ mA})$, 20 ms pulse, $T_c = 25^\circ\text{C}$

Peak Wavelength Shift vs. Junction Temperature

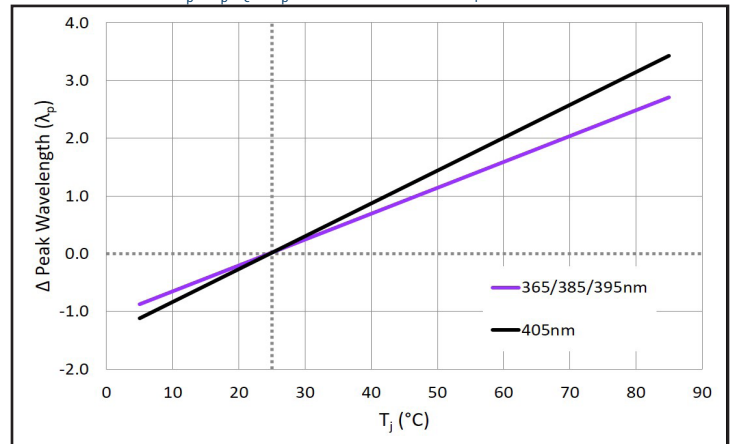
 $\lambda_p = \lambda_p(T_j) - \lambda_p(25^\circ\text{C})$, 20 ms pulse, $I_f = 500\text{ mA}$

Forward Voltage vs Forward Current

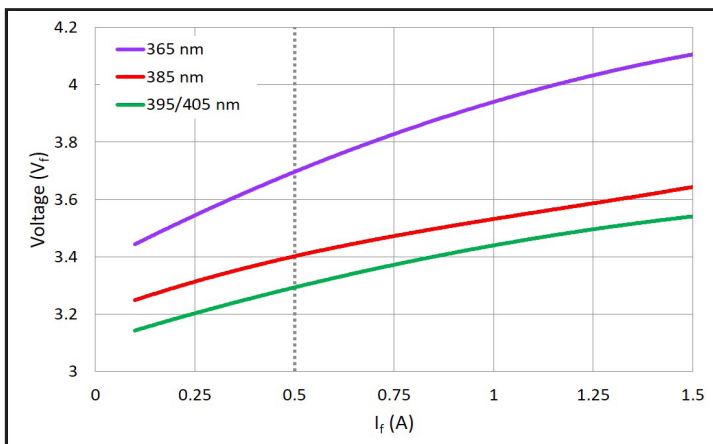

Forward Voltage Shift vs. Junction Temperature

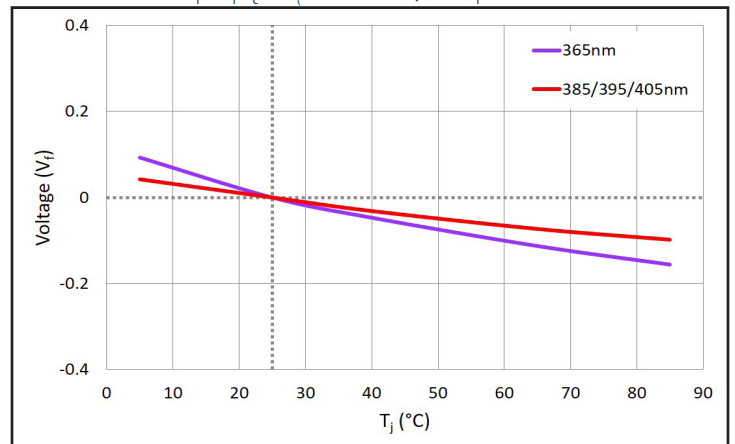
 $\Delta V_f = V_f(T_j) - V_f(25^\circ\text{C})$, 20 ms pulse, $I_f = 500\text{ mA}$

Typical Spectrum⁹

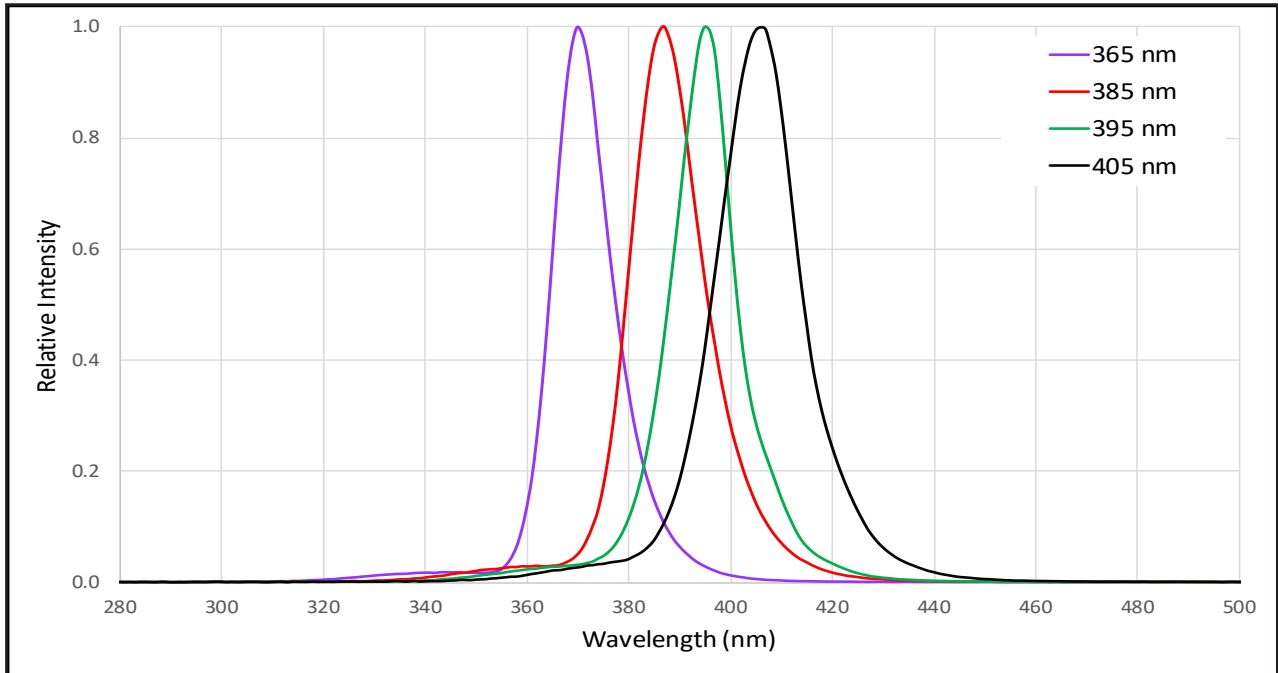

Radiation Pattern¹⁰

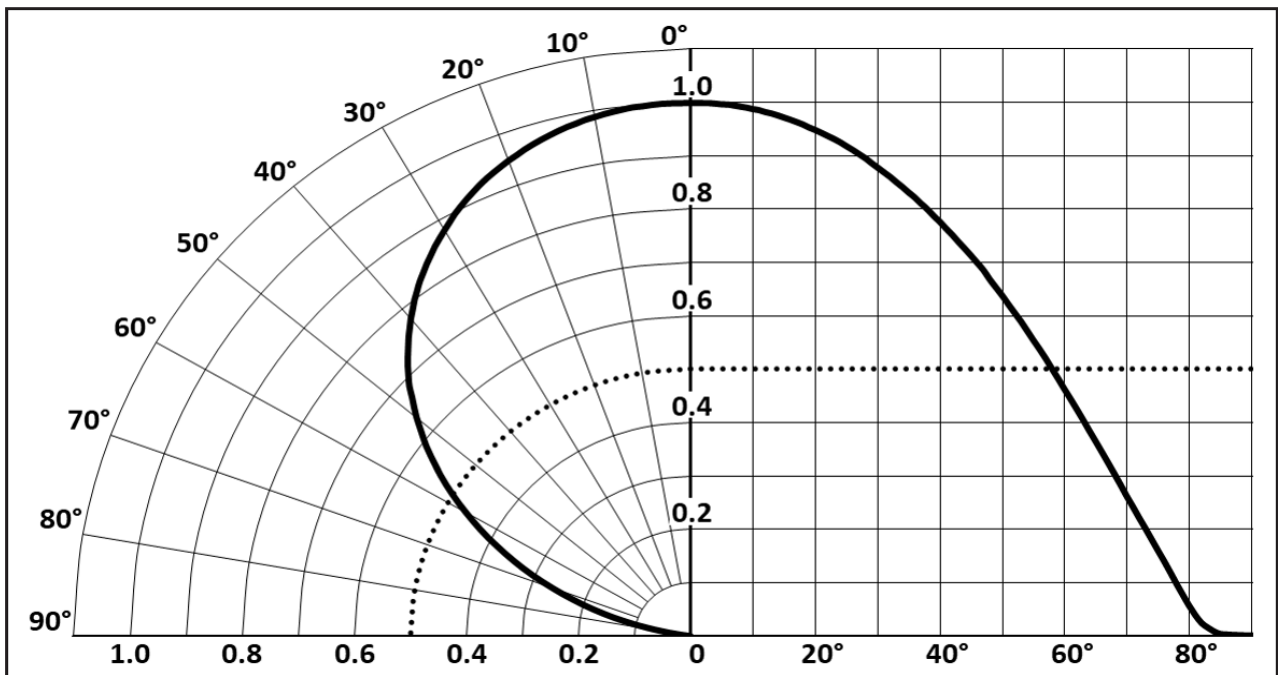

Note 9: Typical spectrum at 500 mA drive current.

Note 10: Detailed information on radiation pattern including ray trace files can be found at: <http://www.luminus.com>

Thermal Resistance

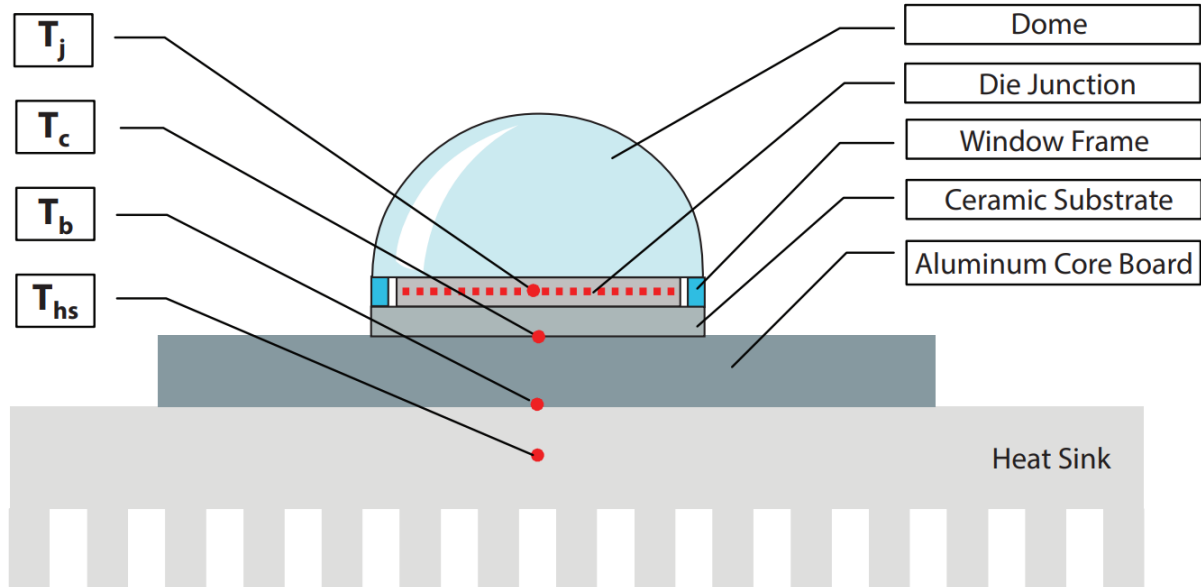

T_{hs} definition = 3 mm from core-board

$R_{\theta j-b}^{11}$	1.4 °C/W
-----------------------	----------

Note 11: Electrical thermal resistance based on input electrical power at 500 mA and measured per JESD51-14

Mechanical Dimensions - A130 package

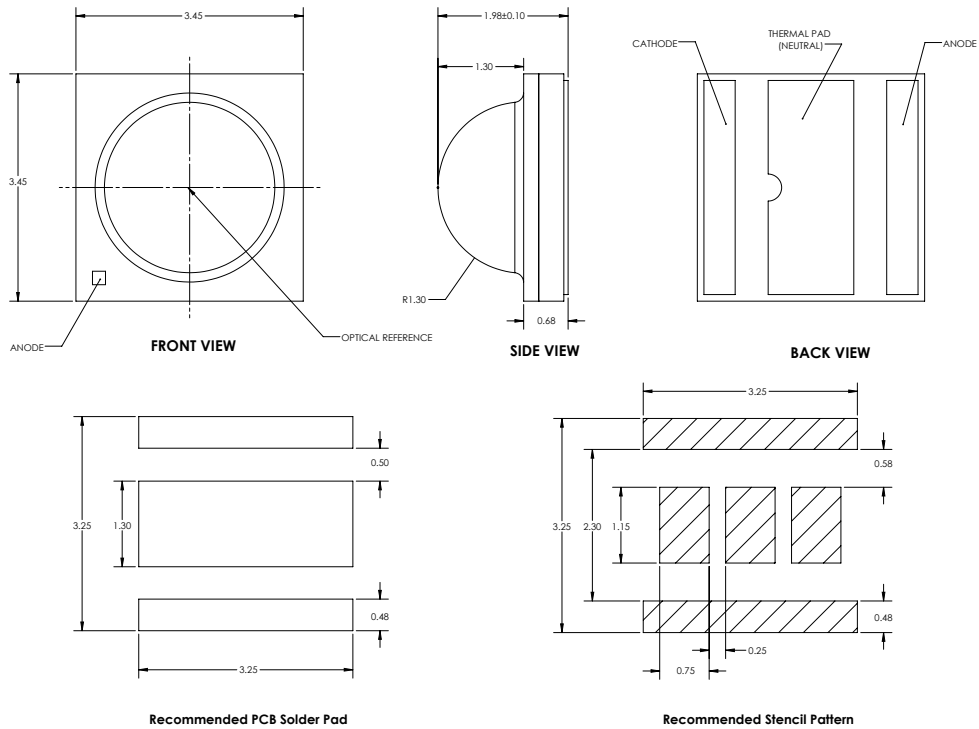

Mechanical Dimensions - B130 package

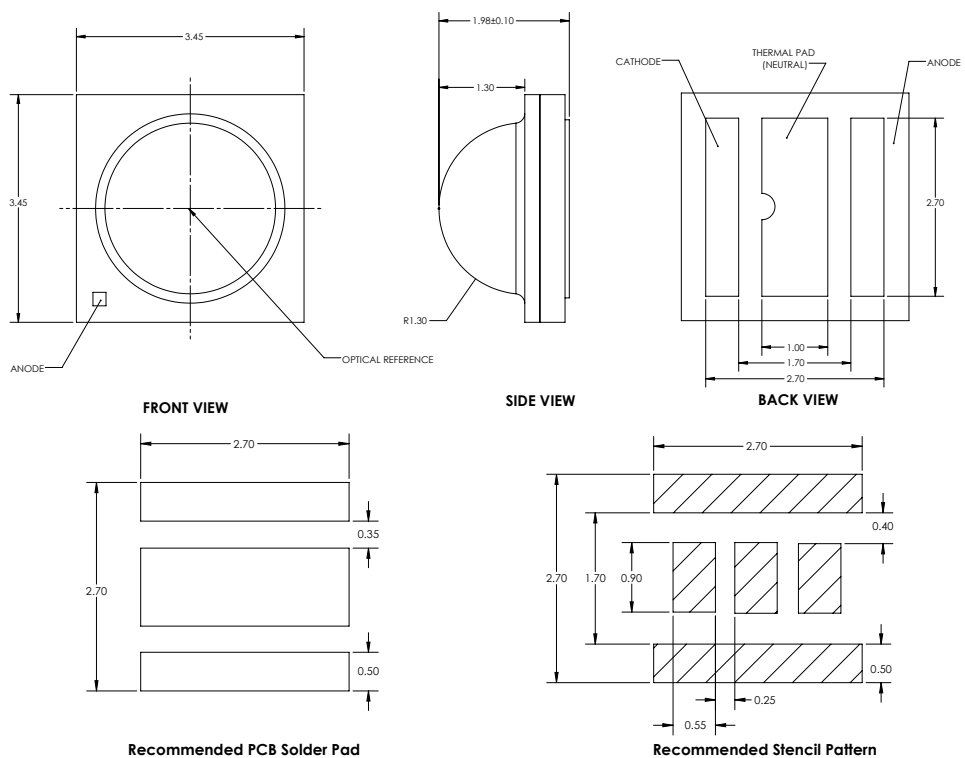

Tape and Reel Outline

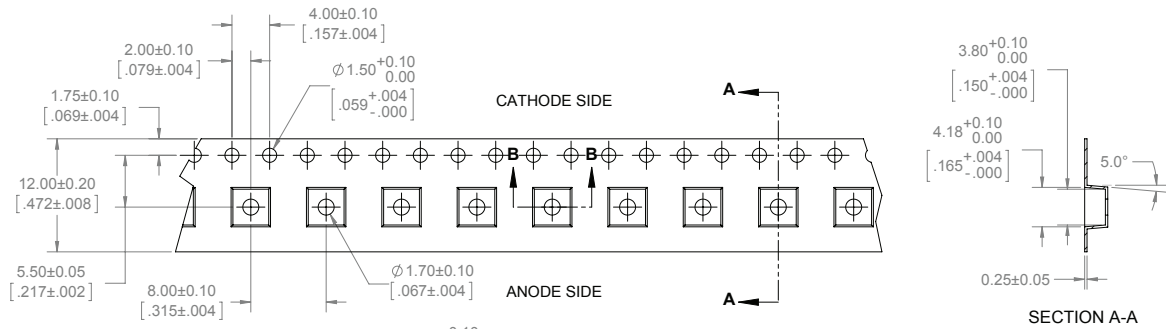

NOTES:

1. FINAL TAPE AND REEL PACKAGING MUST MEET THE REQUIREMENTS OF JEDEC-STD-033, LEVEL 2A.
2. LEAVE 304.8mm [12.00 in] OF TAPE EMPTY FOR LEAD IN (38 EMPTY POCKETS).
3. LEAVE 457.2mm [18.00 in] OF TAPE EMPTY FOR TRAILER (57 EMPTY POCKETS).
4. MUST COMPLY TO EIA-481-C-2003

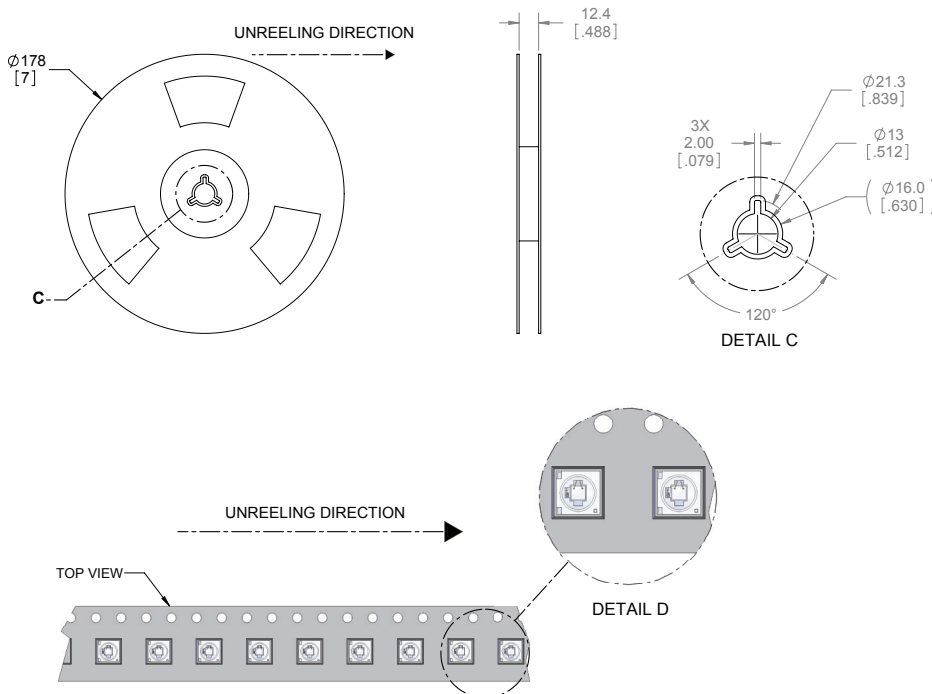

Soldering Profile

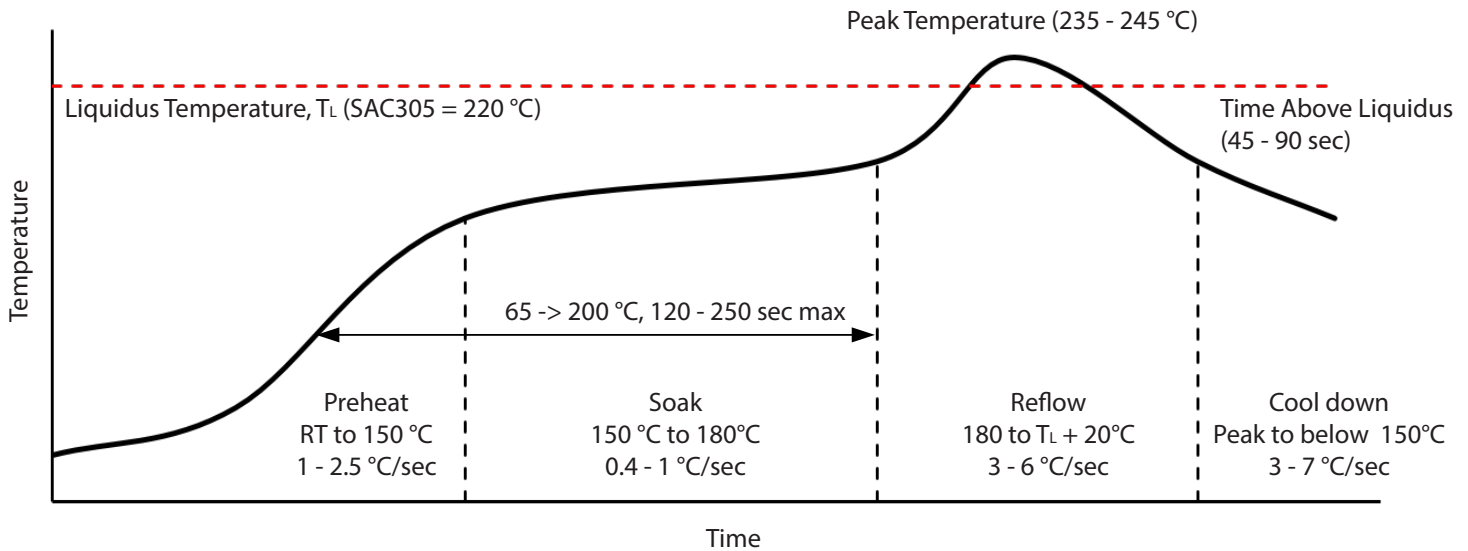

SMT Rework Guideline	Manual Hotplate Reflow	Hot Air Gun Reflow
Heating Time	< 60 sec	
Hotplate Temperature	< 245°C	< 150°C

Note 1: Product complies to Moisture Sensitivity Level 1 (MSL 1).

Note 2: The numbers in the table are specific to SAC305. Luminus recommends using an SAC305 solder paste with a no-clean flux for RoHS compliant products.

Note 3: During the pick and place process, axial forces on the dome (or window) should not exceed 0.5 Newtons (N).

Note 4: Use of a multi-zone IR reflow oven with a nitrogen blanket is recommended.

Note 5: Time-temperature profile of the reflow process showing the four functional profile zones are defined in IPC-7801. Temperature is referenced to the center of the PCB.

Note 6: Luminus recommends to use the solder paste data sheet information as a starting point in time-temperature process development.

Note 7: These are general guidelines. Consult the solder paste manufacturer's datasheet for guidelines specific to the alloy and flux combination used in your application. For more information, please refer to:

<https://luminusdevices.zendesk.com/hc/en-us/articles/360060306692-How-do-I-Reflow-Solder-Luminus-SMD-Components->

Note 8: For any technical questions about soldering process, please contact Luminus at techsupport@luminus.com.

Packing and Shipping Specifications

Product Label Specification

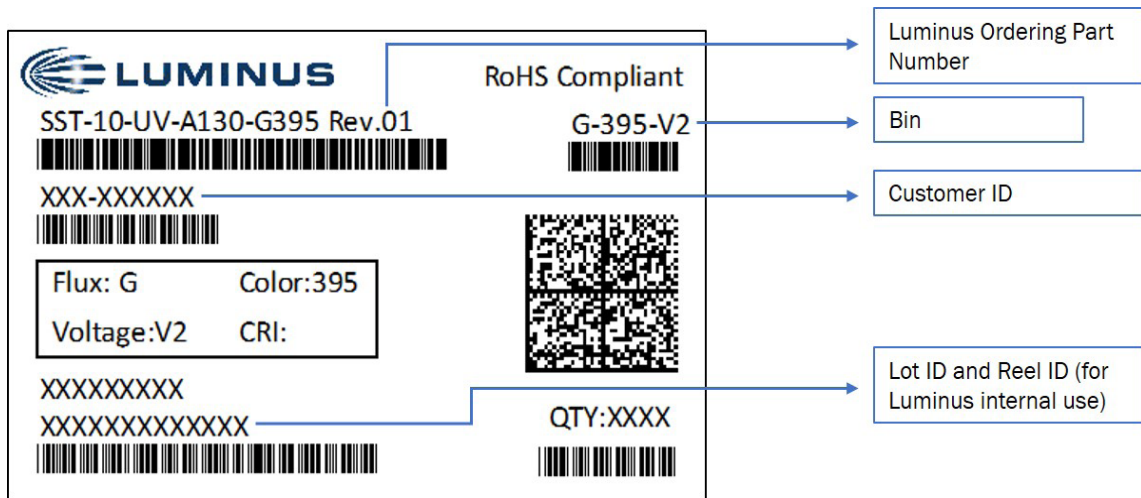

Sample label –for illustration only

Shipping Box

Box Packaging Information

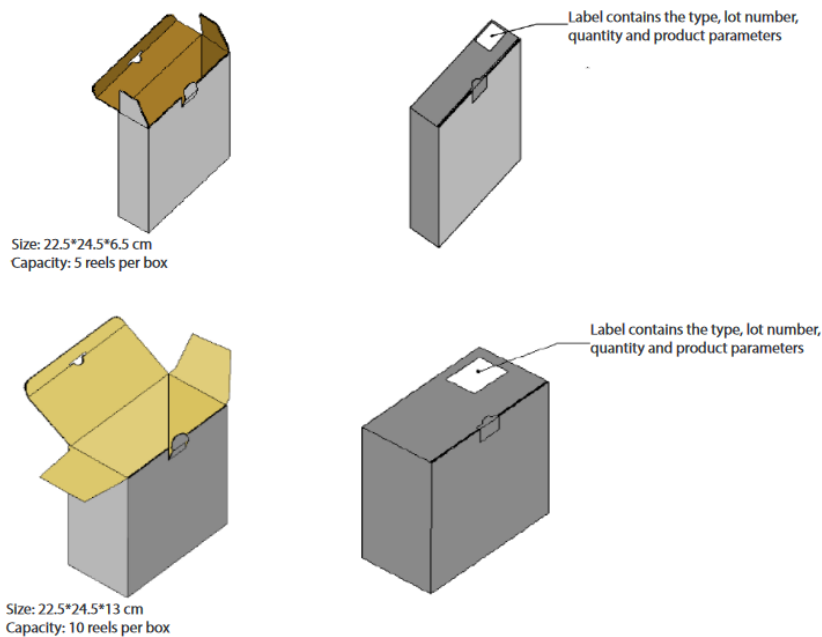

Precautions for storage, handling and use of UV LED components

1. UV Light

SST-10-UV LEDs are short wavelength, UV LEDs. During operation, the LED emits high intensity UVA radiation, which is harmful to skin and eyes. UV light is also hazardous to skin and may cause cancer. Avoid exposure to deep UV light when LED is operational.

Precautions must be taken to avoid looking directly at the UV light without the use of UV light protective glasses. Do not look directly at the front or at the LED's lens when LED is operational.

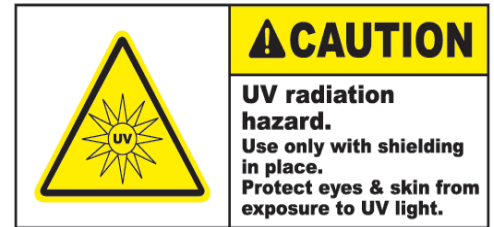
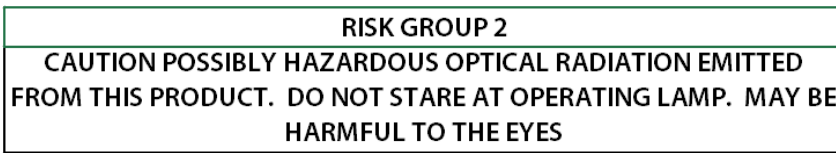

Integration of this LED package into LED sources (arrays, lamps or luminaires) or addition of reflective or magnifying optics may change the expected photobiological safety characteristics of such devices. The assigned risk group classification of the LED package may not necessarily indicate the risk group classification of the LED light source.

2. Operating Conditions

In order to ensure the correct functioning of these LEDs, compliance to maximum allowed specifications is important. UV LEDs are particularly sensitive to drive currents that exceed the max operating specifications and may be damaged by such drive currents. The use of current regulated drive circuits is strongly recommended when operating these devices. Customers should also provide adequate thermal management to ensure LEDs do not exceed maximum recommended temperatures. Operating LEDs at temperatures in excess of specification will result in damage and possibly complete failure of the device.

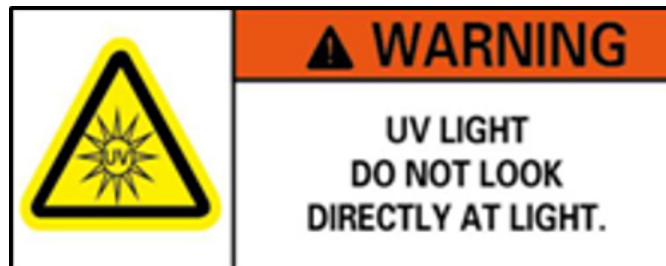

Revision History

Rev	Date	Description of Change
01	06/01/2018	Initial Release
02	8/31/2018	Added "B130" version: updated ordering part numbers, characterization graphs and mechanical drawings
03	6/29/2021	Corrected drawings - add Vf bins - fix typos
04	7/19/2022	Updated ordering bin codes

The products, their specifications and other information appearing in this document are subject to change by Luminus Devices without notice. Luminus Devices assumes no liability for errors that may appear in this document, and no liability otherwise arising from the application or use of the product or information contained herein. None of the information provided herein should be considered to be a representation of the fitness or suitability of the product for any particular application or as any other form of warranty. Luminus Devices' product warranties are limited to only such warranties as accompany a purchase contract or purchase order for such products. Nothing herein is to be construed as constituting an additional warranty. No information contained in this publication may be considered as a waiver by Luminus Devices of any intellectual property rights that Luminus Devices may have in such information.

This product is protected by U.S. Patents 6,831,302; 7,074,631; 7,083,993; 7,084,434; 7,098,589; 7,105,861; 7,138,666; 7,166,870; 7,166,871; 7,170,100; 7,196,354; 7,211,831; 7,262,550; 7,274,043; 7,301,271; 7,341,880; 7,344,903; 7,345,416; 7,348,603; 7,388,233; 7,391,059 Patents Pending in the U.S. and other countries.