

# SERPAC 152AC (exploded isometric)

Electronic Enclosures

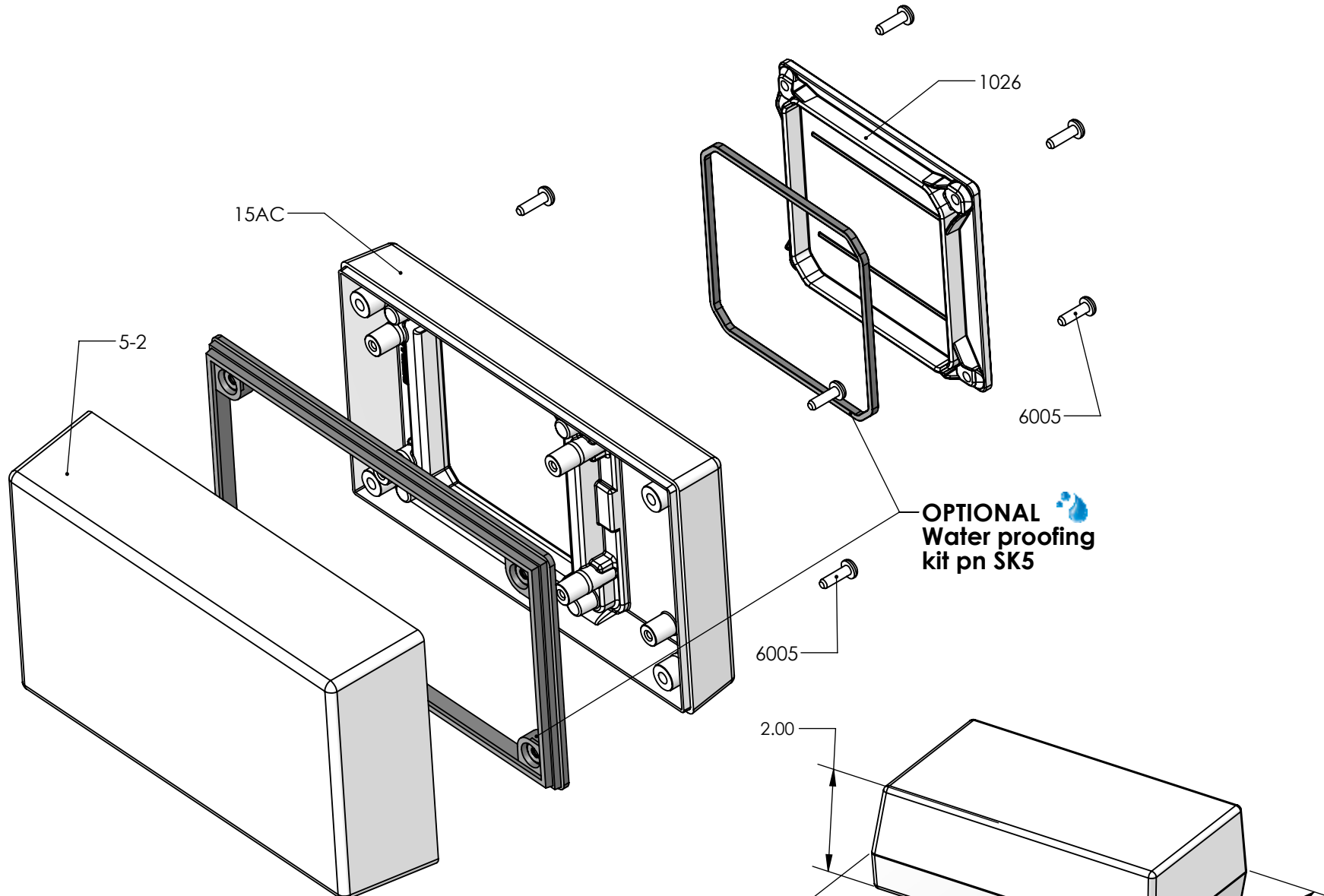

**OPTIONAL**  
Water proofing  
kit pn SK5

PART NO.	DESCRIPTION (Included)	ACCESSORIES (Optional)	
5-2	Top	PART NO.	DESCRIPTION
15AC	AC Bottom	50	Non-skid Feet
1026	Access Door	SK5	Seal Kit for 15X
6005	#4X3/8" Self-Tapping Screw (8)		

Notes: Enclosure weight .31 lb / 142 g  
 1) Enclosure meets or exceeds IP40 and NEMA 1  
 2) When used with SK5 the enclosure meets or exceeds IP 67 and NEMA 4X, 12 and 13 MIL-STD-810G 506.5 (.02 lb / 11g)  
 3) Circuit Board drawings see sheet 3.  
 4) All components are RoHS Compliant.

ALL DIMENSIONS ARE ± .010" 11/15/2021 (1 of 3)  
 2009 Wright Ave. La Verne, CA 91750  
 Ph. (626) 331-0517 Fx. (626) 331-8584 serpac.com

# SERPAC 152AC

Electronic Enclosures

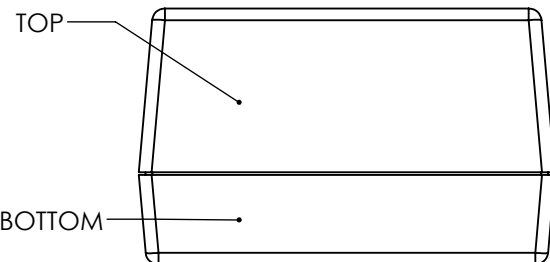
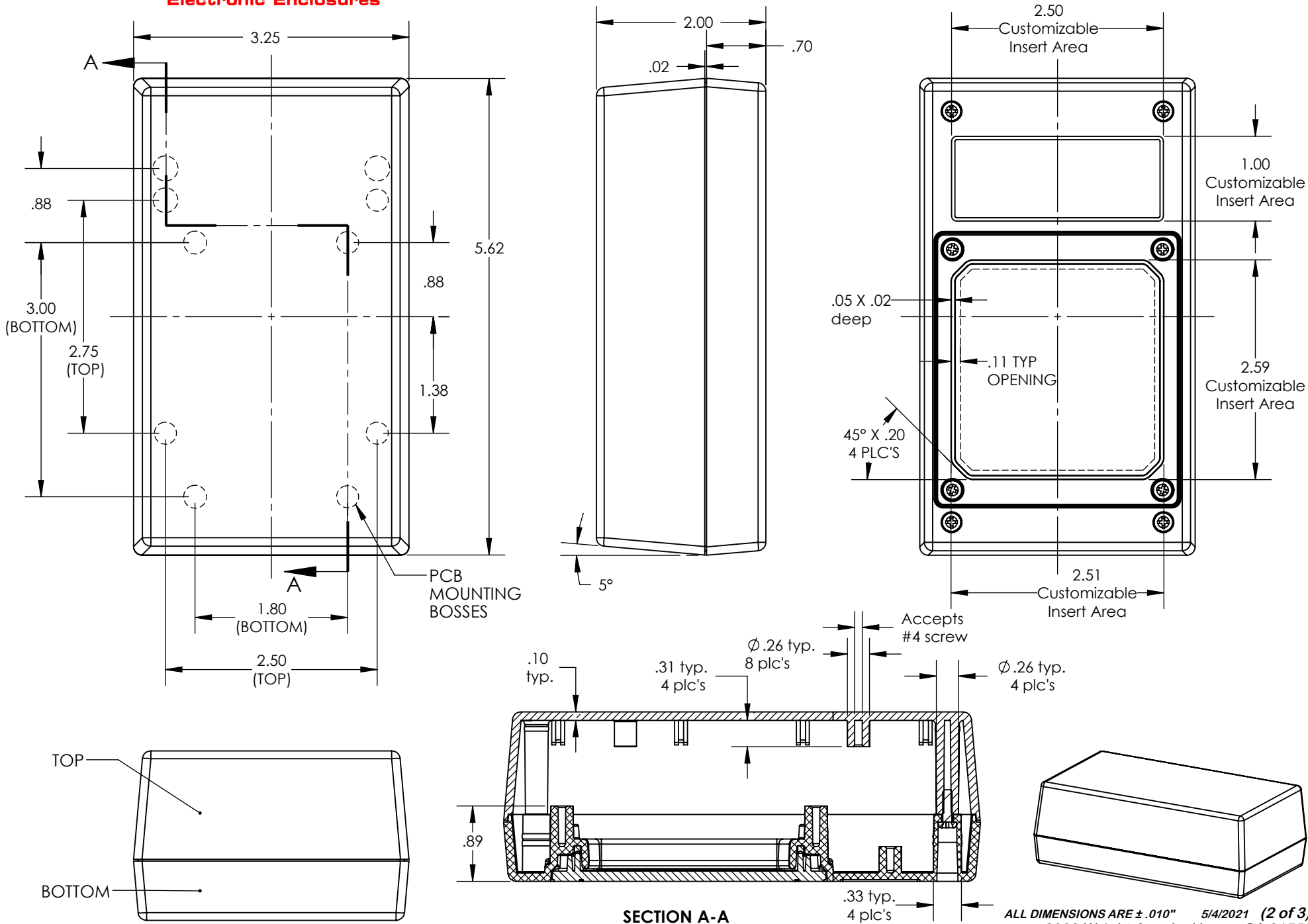

SECTION A-A

ALL DIMENSIONS ARE ± .010" 5/4/2021 (2 of 3)

2009 Wright Ave. La Verne, CA 91750

Ph. (626) 331-0517 Fx. (626) 331-8584 www.serpac.com

# PCB for 15X compartment enclosures

CIRCUIT BOARD FOR TOP

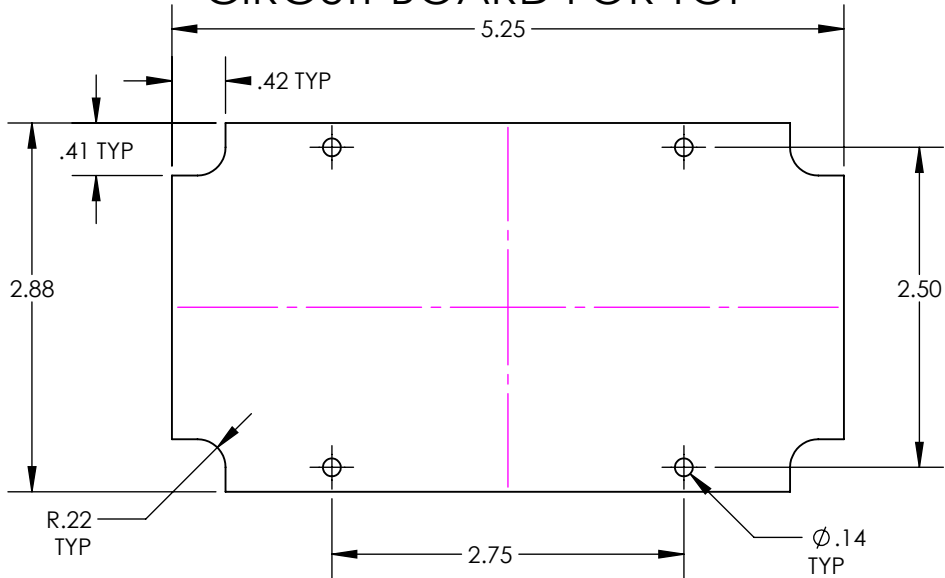

CIRCUIT BOARD FOR BOTTOM

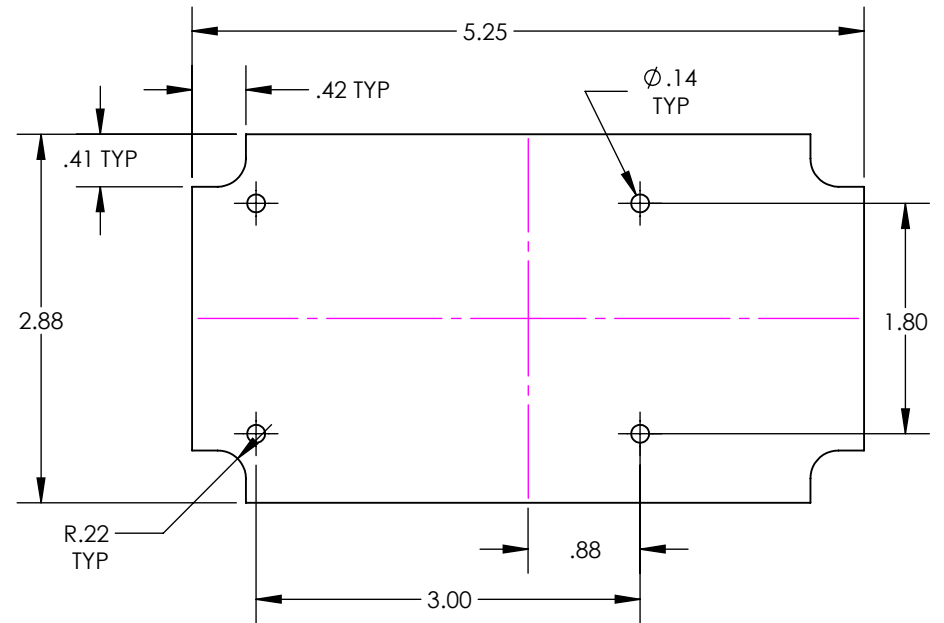

SMALL CIRCUIT BOARD FOR BOTTOM

