

Instruction manual for Evaluation Board of TB67H410FTG

May 16, 2016

Re v.1.0

【Outline】

The TB67H410FTG is a dual channel H-bridge driver corresponding to the constant current PWM control system and the direct PWM control system. It can control two brushed DC motors independently.

BiCD process is adopted. Rating of 50V and 2.5A per channel is realized.

In operating in Large mode, 1ch high current (max. 5.0A) drive is also possible.

This evaluation board mounts necessary components to evaluate the IC.

Brushed DC motor can be controlled by the constant current PWM drive and the direct PWM drive.

Please sense controllability of brushed DC motor applying the TB67H410FTG.

【Note】

In using, please be careful about thermal condition sufficiently.

As for each control signal, please refer to the IC specification by accessing to the below URL.

<http://toshiba.semicon-storage.com/info/lookup.jsp?pid=TB67H410FTG&lang=en®ion=apc&sug=1>

Further, the application of this evaluation board is limited to the purpose of evaluating and learning the motor control. Please do not ship them to a market.

Connection to Evaluation board

Corresponding table

(Silk name vs. Signal name)

(Note) Silk name and signal name on the board are different because the series products have the common board.

Silk name	Signal name
L_OUT	NC
38	NC
39	NC
VREFB	VREF
42	HBMODE
OSCM	OSCM
44	INA1
45	INA2
46	PWMA
47	PWMB
2	INB1
3	INB2
4	TBLKAB

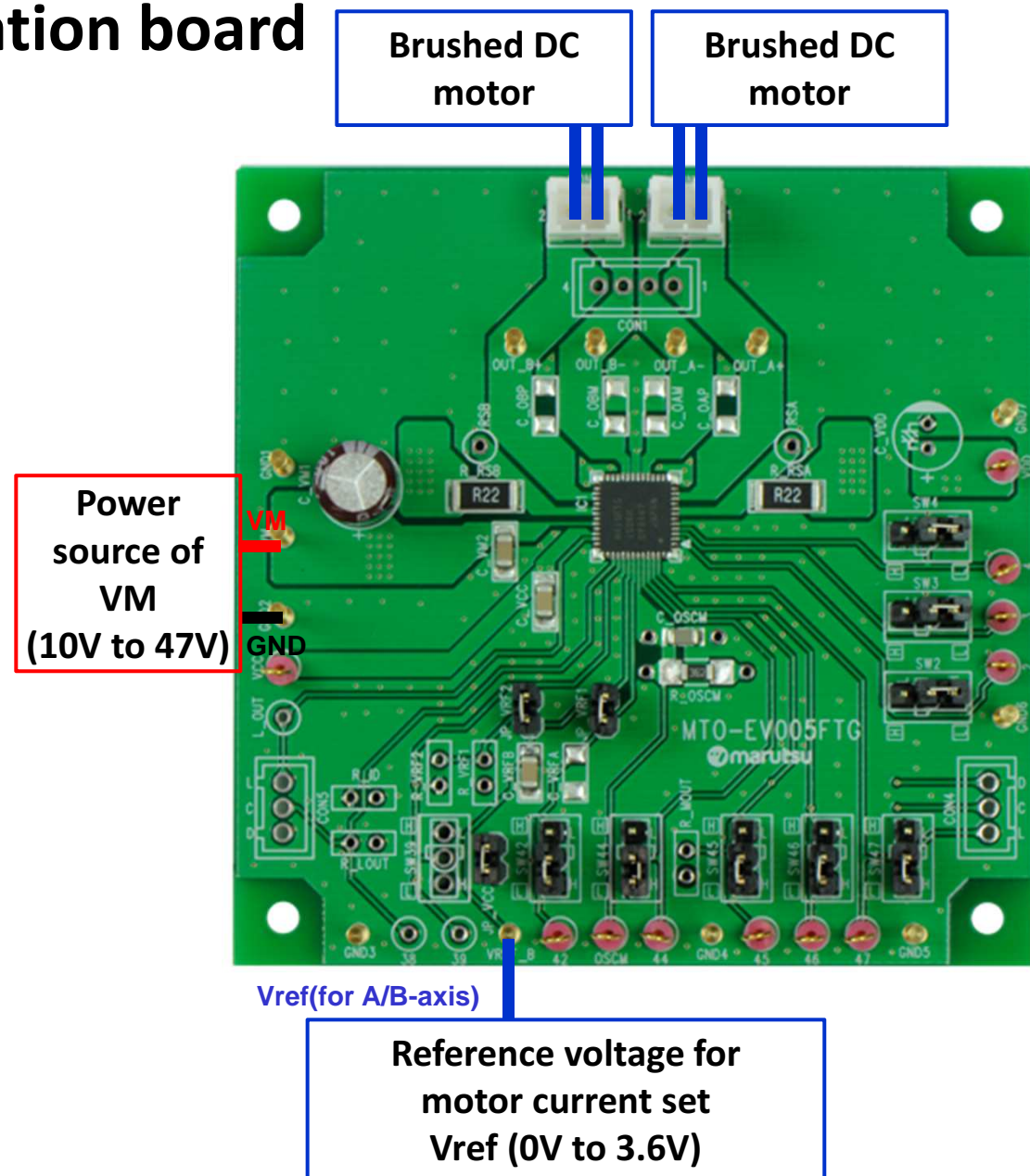

Setting evaluation board1

Setting motor current

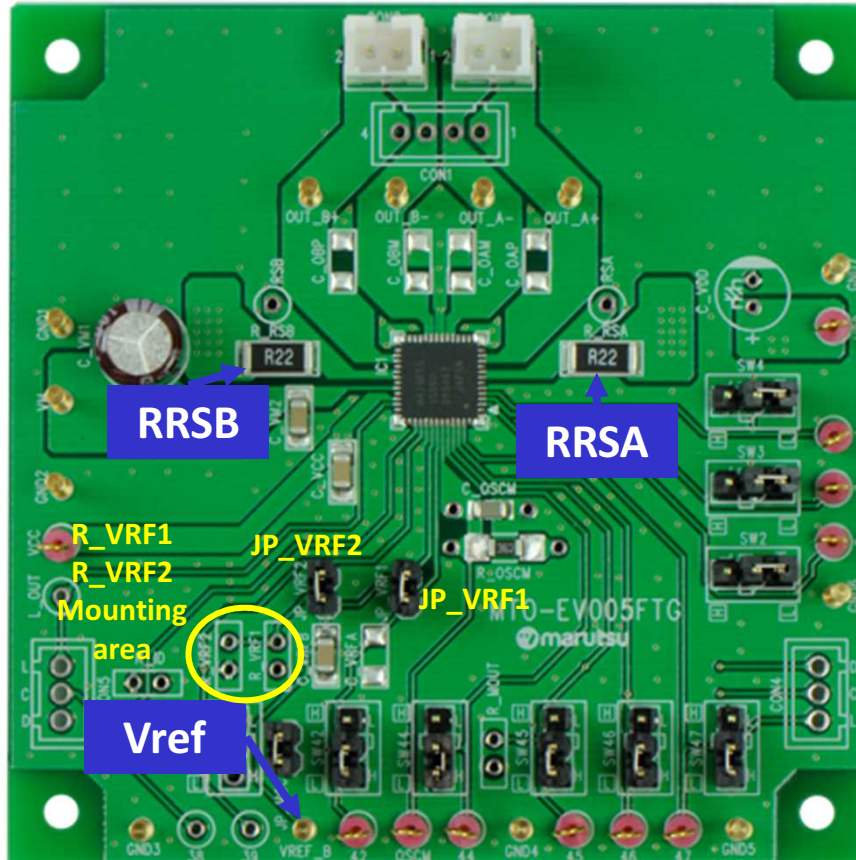

Setting motor current

$$I_{out(max)} = V_{REF}(gain) \times \frac{V_{ref}(V)}{R_{RS}(\Omega)}$$

$V_{REF}(gain)$: Decay ratio of V_{REF} : 1/5.0 (typ.)

$R_{RS}=0.22\Omega$

V_{ref} can be generated from the internal regulator (VCC) by mounting the divider resistance to R_{VRF1} and R_{VRF2} and short-circuiting JP_{VRF2} .

Waveform of motor current

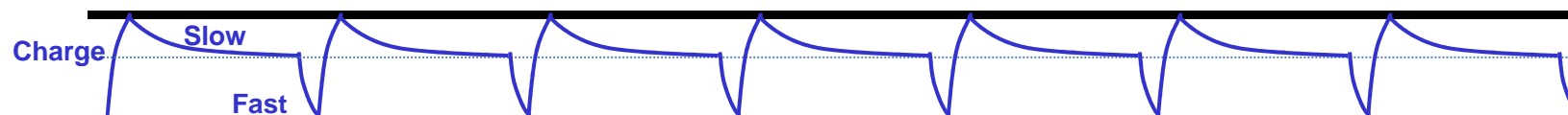

Setting evaluation board2

Setting chopping frequency of the constant current of the motor

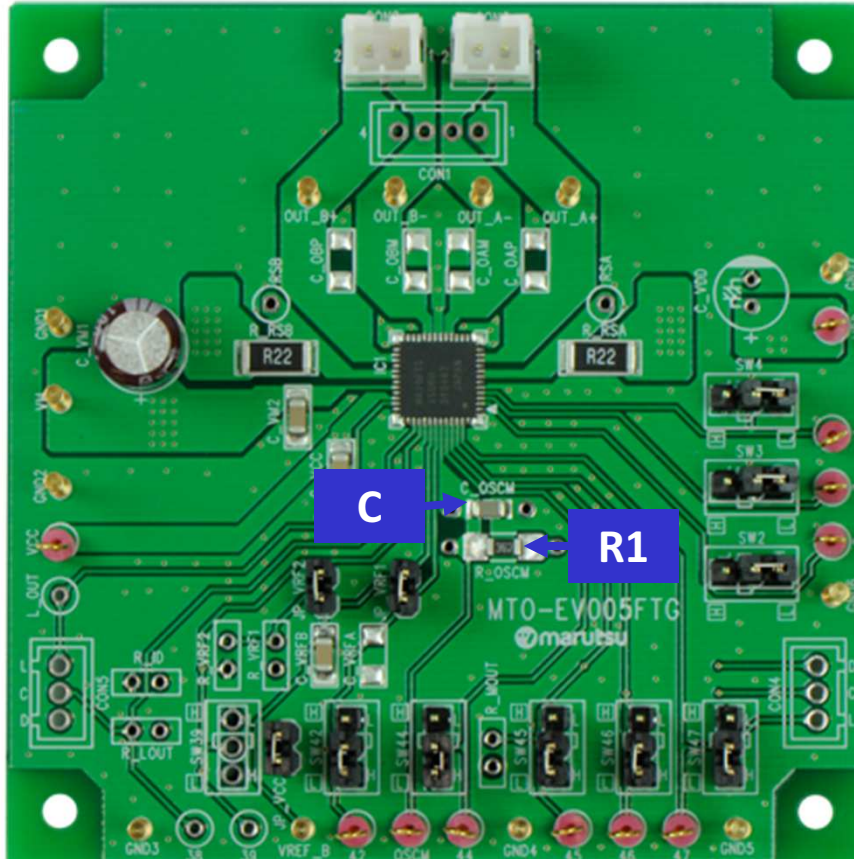

Formula of setting chopping frequency

$$f_{OSCM} = 1 / [0.56 \times \{C \times (R1 + 500)\}]$$

$$f_{chop} = f_{OSCM} / 16$$

Recommended frequency range:

f_{chop} =40kHz to 150kHz

100kHz configuration

Mounted parts are as follows;

Capacitor (C=270pF), Resistance (R1=3.6kΩ)

Waveform of motor current

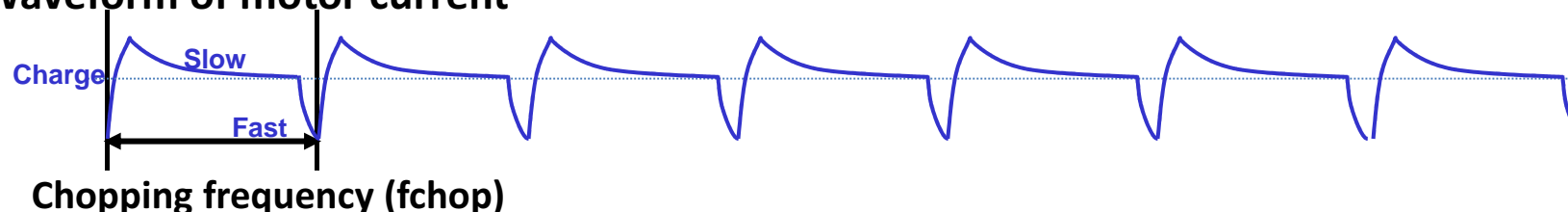

Setting evaluation board3

Setting motor operation

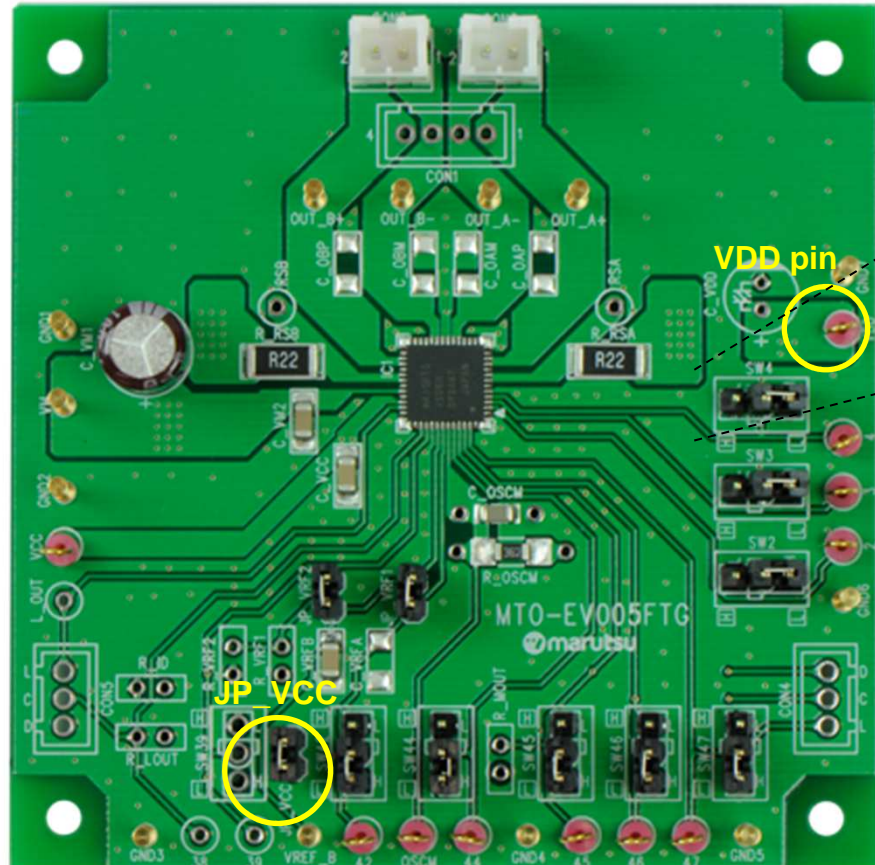

【Enhanced figure of jumper part】

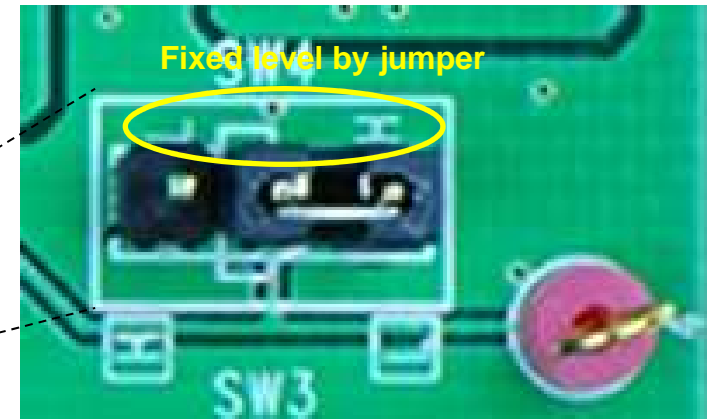

Jumper indicated above is adopted on this evaluation board to set operation of the TB67H410FTG.

To select the function by the jumper, short-circuit JP_VCC or supply the voltage of high level by VDD pin.

In above, fixed level of the silk near the jumper is indicated inside the white frame. Please change the short position according to the configuration of the usage function.

In case of inputting the signal externally, please remove the short pin.

Circuit of evaluation board

