

|       |               |
|-------|---------------|
| $V_R$ | 650V          |
| $I_F$ | 10A/20A*      |
| $Q_C$ | 15nC(Per leg) |

(\*Per leg/ Both legs)

### ●Features

- 1) Low forward voltage
- 2) Negligible recovery time/current
- 3) Temperature independent switching behavior

### ●Applications

- Switch Mode Power Supply
- Uninterruptible Power Supply
- Solar Inverter
- Motor Drive
- Air Conditioner
- EV Charger

### ●Absolute maximum ratings ( $T_{vj} = 25^{\circ}\text{C}$ )

| Parameter  | Symbol        | Value  | Unit               |                      |
|--|---------------|--|--------------------|----------------------|
| Reverse voltage (repetitive peak)                            | $V_{RM}$      | 650  | V                  |                      |
| Reverse voltage (DC)   | $V_R$         | 650  | V                  |                      |
| Continuous forward current*3 ( $T_c = 137^{\circ}\text{C}$ ) | $I_F$         | 10/20  | A                  |                      |
| Surge non-repetitive forward current*3                       | $I_{FSM}$     | PW=10ms sinusoidal, $T_{vj}=25^{\circ}\text{C}$  | 38/76              | A                    |
|  |               | PW=10ms sinusoidal, $T_{vj}=150^{\circ}\text{C}$ | 30/60              | A                    |
|  |               | PW=10μs square, $T_{vj}=25^{\circ}\text{C}$      | 150/300            | A                    |
| Repetitive peak forward current*3                            | $I_{FRM}$     | 45/91 *1   | A                  |                      |
| $i^2t$ value*3   | $\int i^2 dt$ | PW=10ms, $T_{vj}=25^{\circ}\text{C}$             | 7.2/29             | $\text{A}^2\text{s}$ |
|  |               | PW=10ms, $T_{vj}=150^{\circ}\text{C}$            | 4.5/18             | $\text{A}^2\text{s}$ |
| Total power dissipation *3                                   | $P_D$         | 83/160 *2  | W                  |                      |
| Virtual Junction temperature                                 | $T_{vj}$      | 175  | $^{\circ}\text{C}$ |                      |
| Range of storage temperature                                 | $T_{stg}$     | -55 to +175                                      | $^{\circ}\text{C}$ |                      |

\*1  $T_c=100^{\circ}\text{C}$ ,  $T_{vj}=150^{\circ}\text{C}$ , Duty cycle=10% \*2  $T_c=25^{\circ}\text{C}$  \*3 Per leg/ Both legs

### ●Outline

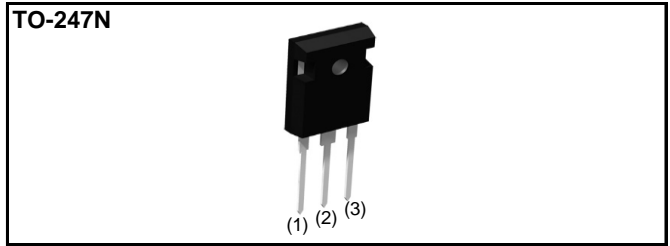

### ●Inner circuit

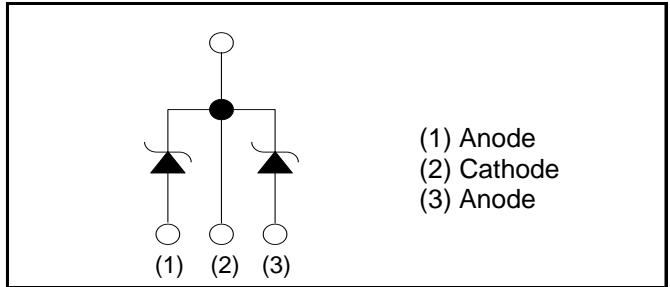

### ●Packaging specifications

| Package | TO-247N                   |           |
|---------|---------------------------|-----------|
| Type    | Packing                   | Tube      |
|         | Reel size (mm)            | -         |
|         | Tape width (mm)           | -         |
|         | Basic ordering unit (pcs) | 30        |
|         | Packing code              | C11       |
|         | Marking                   | SCS220AE2 |

**●Electrical characteristics** ( $T_{vj} = 25^{\circ}\text{C}$ ) (Per Leg)

| Parameter               | Symbol   | Conditions                                       | Values |      |      | Unit          |
|-------------------------|----------|--|--------|------|------|---------------|
|                         |          |  | Min.   | Typ. | Max. |               |
| DC blocking voltage     | $V_{DC}$ | $I_R=2.0\text{mA}$                               | 650    | -    | -    | V             |
| Forward voltage         | $V_F$    | $I_F=10\text{A}, T_{vj}=25^{\circ}\text{C}$      | -      | 1.35 | 1.55 | V             |
|                         |          | $I_F=10\text{A}, T_{vj}=150^{\circ}\text{C}$     | -      | 1.55 | -    | V             |
|                         |          | $I_F=10\text{A}, T_{vj}=175^{\circ}\text{C}$     | -      | 1.63 | -    | V             |
| Reverse current         | $I_R$    | $V_R=600\text{V}, T_{vj}=25^{\circ}\text{C}$     | -      | 2    | 200  | $\mu\text{A}$ |
|                         |          | $V_R=600\text{V}, T_{vj}=150^{\circ}\text{C}$    | -      | 30   | -    | $\mu\text{A}$ |
|                         |          | $V_R=600\text{V}, T_{vj}=175^{\circ}\text{C}$    | -      | 70   | -    | $\mu\text{A}$ |
| Total capacitance       | C        | $V_R=1\text{V}, f=1\text{MHz}$                   | -      | 360  | -    | pF            |
|                         |          | $V_R=600\text{V}, f=1\text{MHz}$                 | -      | 37   | -    | pF            |
| Total capacitive charge | $Q_C$    | $V_R=400\text{V}, di/dt=350\text{A}/\mu\text{s}$ | -      | 15   | -    | nC            |
| Switching time          | $t_C$    | $V_R=400\text{V}, di/dt=350\text{A}/\mu\text{s}$ | -      | 15   | -    | ns            |

**●Thermal characteristics**

| Parameter          | Symbol     | Conditions | Values |      |      | Unit |
|--------------------|------------|------------|--------|------|------|------|
|                    |            |            | Min.   | Typ. | Max. |      |
| Thermal resistance | $R_{thJC}$ | Per Leg    | -      | 1.6  | 1.8  | K/W  |
|                    |            | Both Legs  | -      | 0.80 | 0.90 | K/W  |

**●Typical Transient Thermal Characteristics (Per Leg)**

| Symbol    | Value                 | Unit | Symbol    | Value                 | Unit |
|-----------|-----------------------|------|-----------|-----------------------|------|
| $R_{th1}$ | $4.16 \times 10^{-1}$ | K/W  | $C_{th1}$ | $1.55 \times 10^{-3}$ | Ws/K |
| $R_{th2}$ | $9.92 \times 10^{-1}$ |      | $C_{th2}$ | $6.13 \times 10^{-3}$ |      |
| $R_{th3}$ | $1.93 \times 10^{-1}$ |      | $C_{th3}$ | $1.34 \times 10^{-1}$ |      |

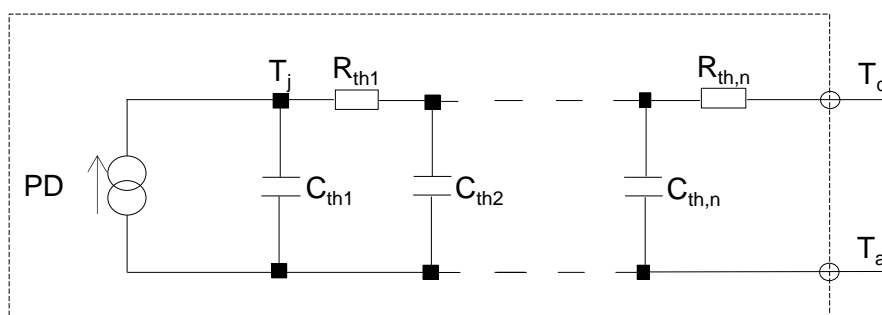

●Electrical characteristic curves

Fig.1  $V_F - I_F$  Characteristics (Per Leg)

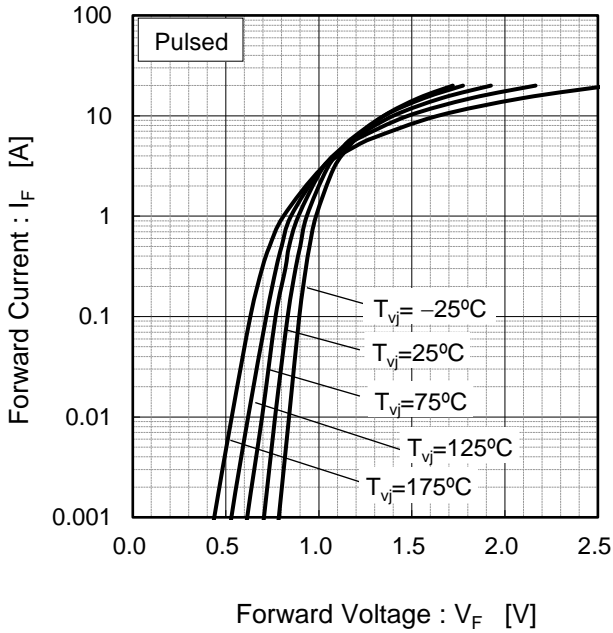

Fig.2  $V_F - I_F$  Characteristics (Per Leg)

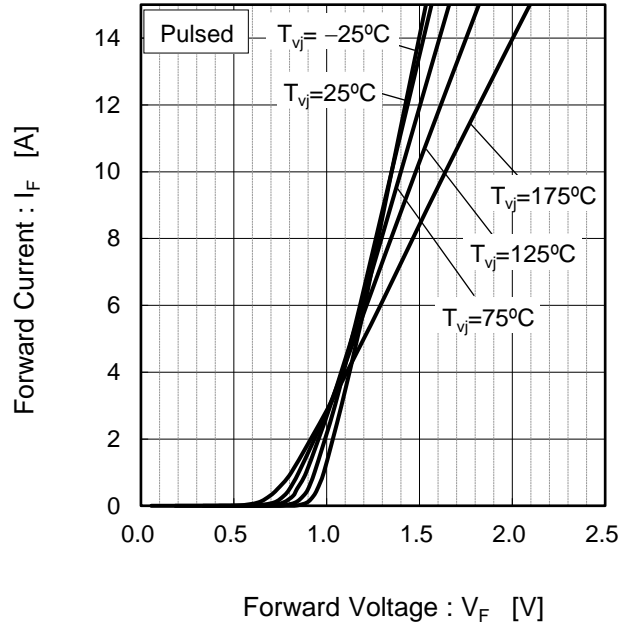

Fig.3  $V_R - I_R$  Characteristics (Per Leg)

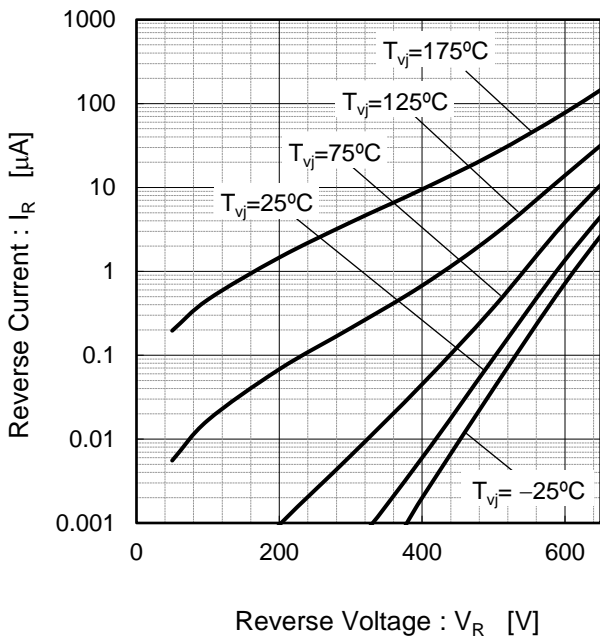
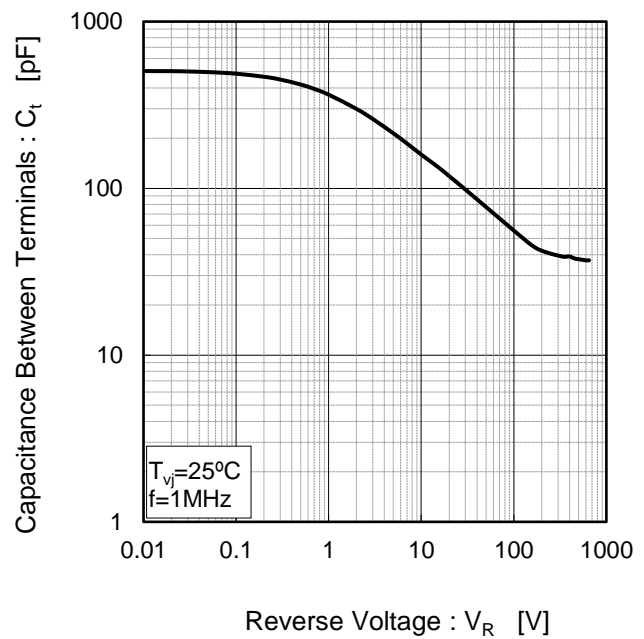

Fig.4  $V_R - C_t$  Characteristics (Per Leg)



●Electrical characteristic curves

Fig.5 Typical Transient Thermal Impedance vs. Pulse Width (Per Leg)

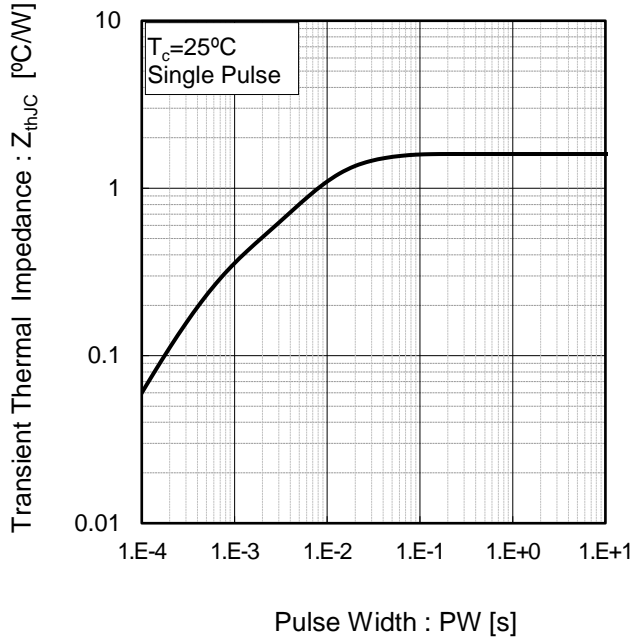

Fig.6 Power Dissipation (Per Leg)

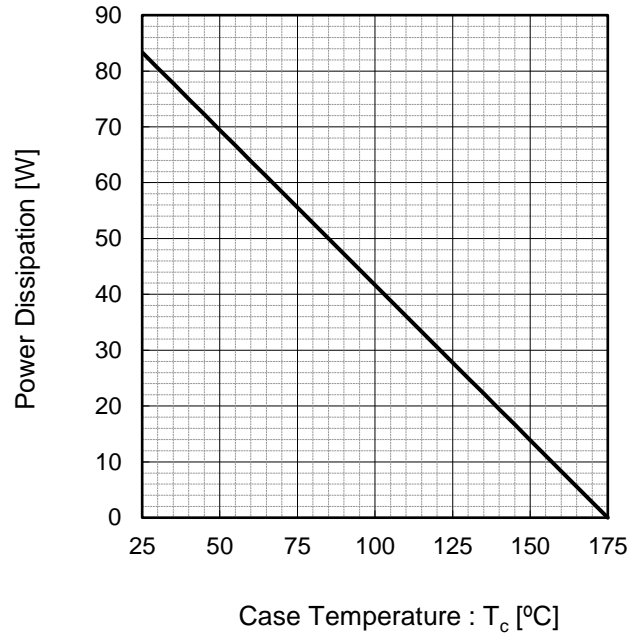
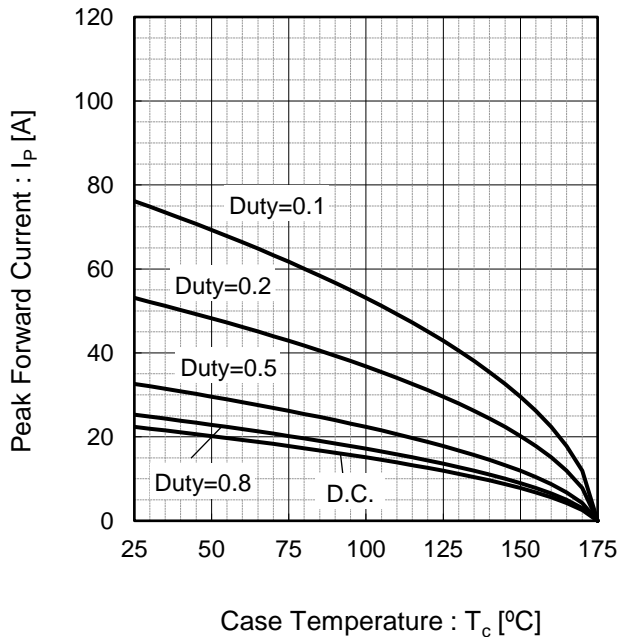
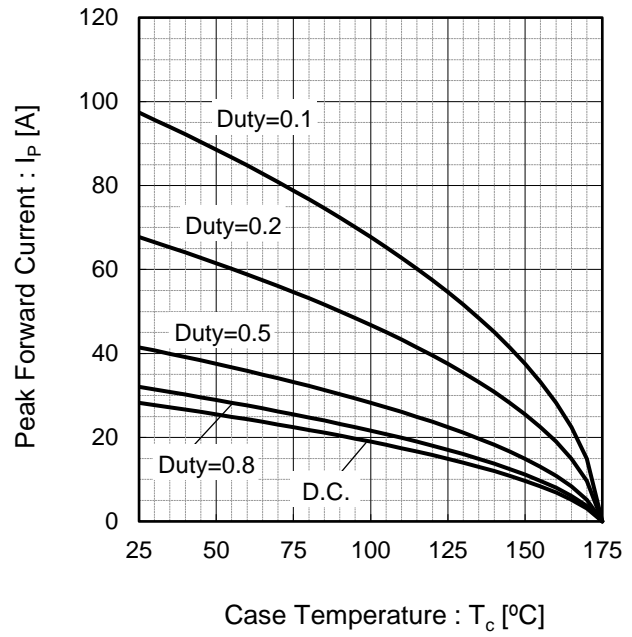

Fig.7\*4 Maximum peak forward current derating curve  $I_P - T_C$  (Per Leg)



Case Temperature :  $T_C$  [°C]  
 \*4 Based on max Vf, max  $R_{thJC}$   
 Valid for switching of above 10kHz,  
 excluding D.C. curve.

Fig.8\*5 Typical peak forward current derating curve  $I_P - T_C$  (Per Leg, Not guaranteed)



Case Temperature :  $T_C$  [°C]  
 \*5 Based on typ Vf, typ  $R_{thJC}$   
 Typical value, not guaranteed  
 Valid for switching of above 10kHz,  
 excluding D.C. curve

●Electrical characteristic curves

Fig.9 Surge non-repetitive forward current vs. Pulse width (Sinusoidal waveform) (Per Leg)

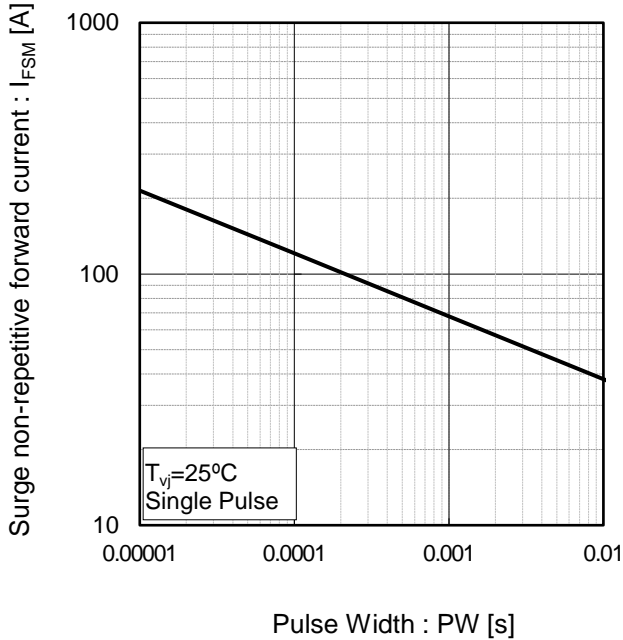
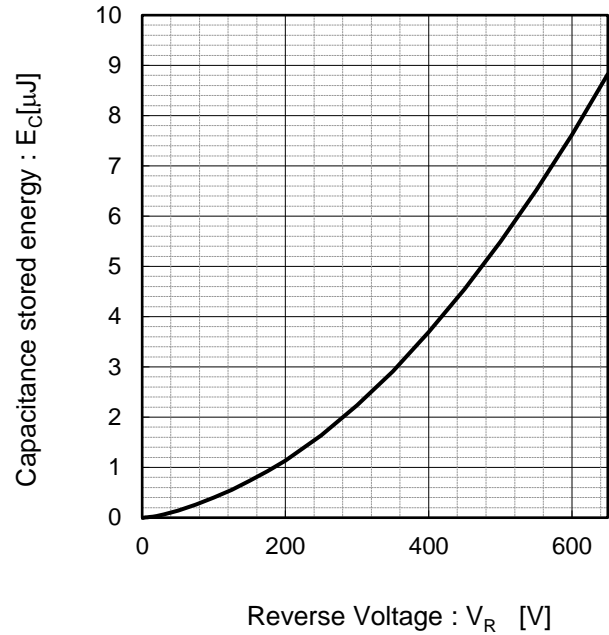
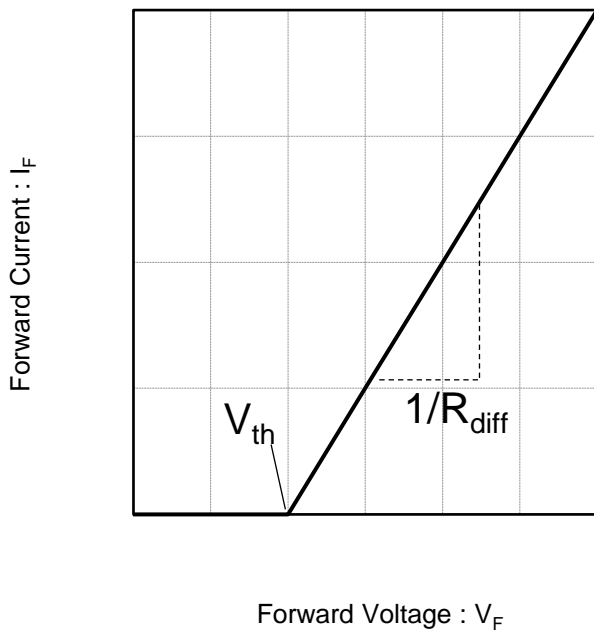

Fig.10 Typical capacitance store energy (Per Leg)



●Simplified forward characteristic model (Per Leg)

Fig.11 Equivalent forward current curve



$$V_F = V_{th} + R_{diff} I_F$$

$$V_{th} ( T_{vj} ) = a_0 + a_1 T_{vj}$$

$$R_{diff} ( T_{vj} ) = b_0 + b_1 T_{vj} + b_2 T_{vj}^2$$

| Symbol | Typical Value          | Unit              |
|--------|------------------------|-------------------|
| $a_0$  | $9.35 \times 10^{-1}$  | V                 |
| $a_1$  | $-1.12 \times 10^{-3}$ | V/°C              |
| $b_0$  | $3.98 \times 10^{-2}$  | Ω                 |
| $b_1$  | $1.02 \times 10^{-4}$  | Ω/°C              |
| $b_2$  | $1.08 \times 10^{-6}$  | Ω/°C <sup>2</sup> |

$T_{vj}$  in °C;  $-55\text{ °C} < T_{vj} < 175\text{ °C}$ ;  $I_F < 20\text{ A}$

## ● Package Dimensions

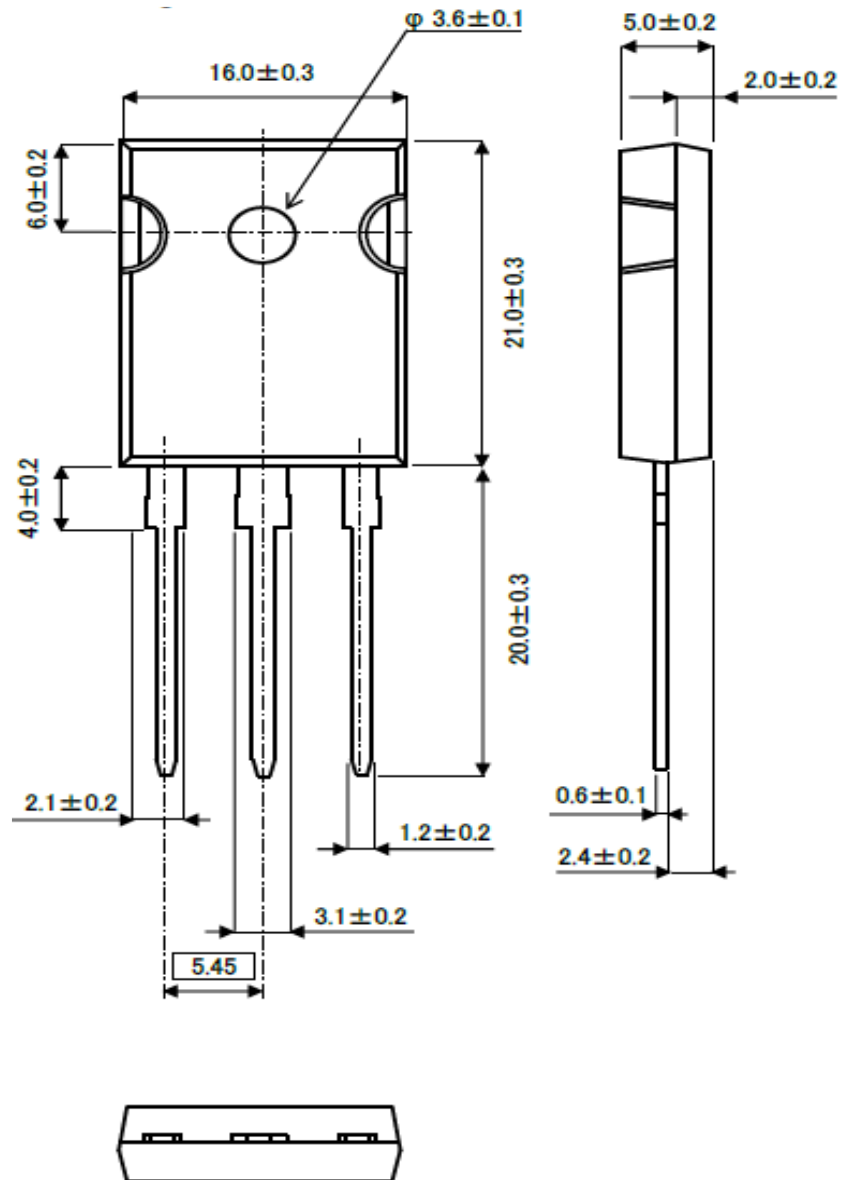

Unit: mm

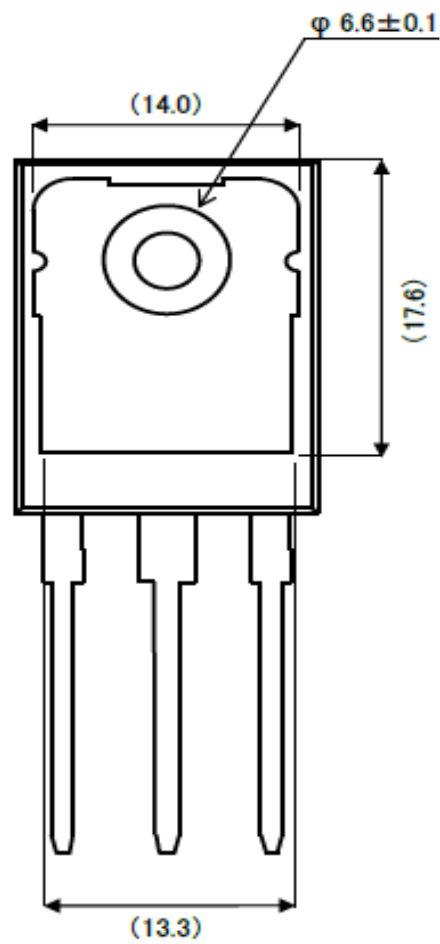

Unit: mm

## ●Die Bonding Layout

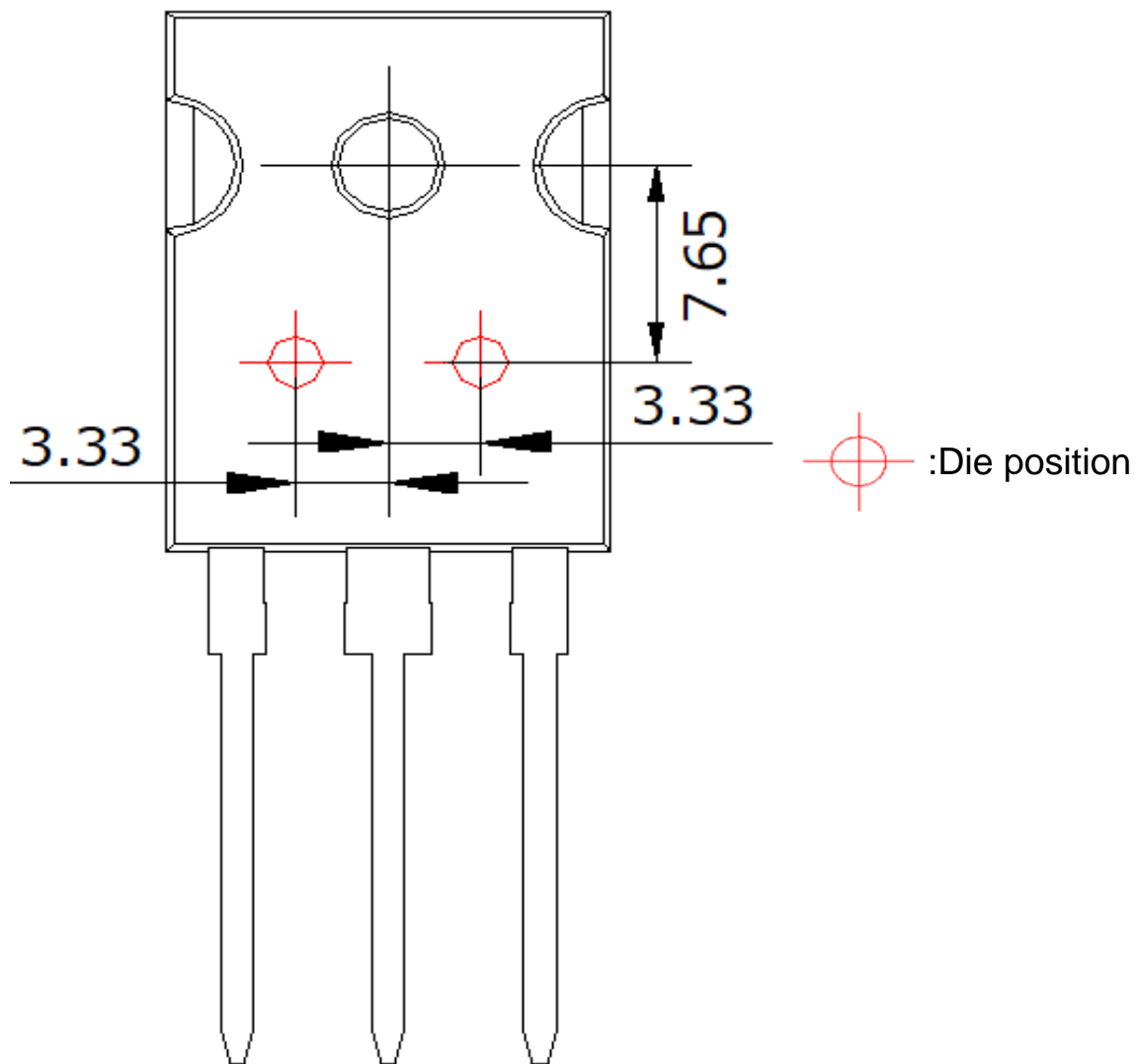

- Front view of the packaging.
- Dimensions are design values.
- If the heat sink is to be installed, it should be in contact with the die bonding point.

Unit: mm