

AGV-TMR250V

(analog voltage output)

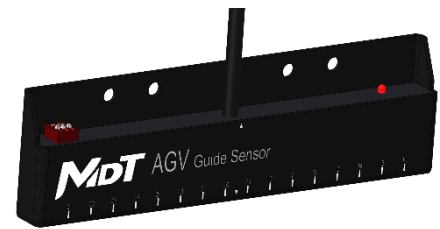

AGV Magnetic Guide Sensors

DESCRIPTION

AGV-TMR250V is an analog voltage output magnetic guide sensor, and the V_{out} voltage is linear to the distance between magnetic tape and sensor. It is available as standard with N pole, S pole and N/S pole magnetic operating modes including corresponding LED indicators. AGV-TMR250V provides branch selection function, enabling “straight”, “left branch” and “right branch” three analog output modes by acquiring ground mark information to set the signals of SET1 and SET2 pins in advance. This sensor also supports magnetic tape presence status indication from STATE pin.

AGV-TMR250V sensor is adaptive to installation height and tape width with excellent protection against magnetic material interference. Incorporating tunneling magnetoresistance (TMR) technique, AGV-TMR250V sensors are designed for magnetic tape and marker detection to provide excellent temperature characteristics, good consistency, and high sensitivity performance.

FEATURES AND BENEFITS

- Analog voltage output
- Branch selection function
- Tape presence status detection
- Adaptive installation height
- Adaptive magnetic tape width
- Magnetic tape/marker detection
- N pole, S pole and N/S poles detection modes
- LED indicators for operating modes

APPLICATIONS

- Automated guided vehicle (AGV)
- Automated guided cart (AGC)
- Trackless mobile shelving
- Logistics sortation

AGV-TMR250V (analog voltage output)

AGV Magnetic Guide Sensors

SPECIFICATIONS

Parameters	Value
Supply voltage	10 Vdc ~ 30 Vdc
Supply current	50 mA
Output type	Analog voltage
Voltage range	2V ~ 8V
Center voltage	5V
Voltage resolution	3 mV
Detection height	20 mm~50 mm
Load resistance	10 kΩ~100 kΩ
Circuit protection	reverse polarity protection, overload protection, surge suppression
Operating mode	N pole, S pole, N/S pole
LED indicator	N: red stay lit, S: green stay lit, N/S: red/green alternating blink
Magnetic field	5 Gs~25 Gs
Operating temperature	-25°C~80°C
Operating humidity	35%~95%
Response time	1 ms
Dimensions	178 mm*17 mm*50 mm
Potting material	AB glue
Housing material	Metal, Epoxy Resin
Ingress Protection	IP65

SENSOR INSTALLATION SCHEMATIC DIAGRAM

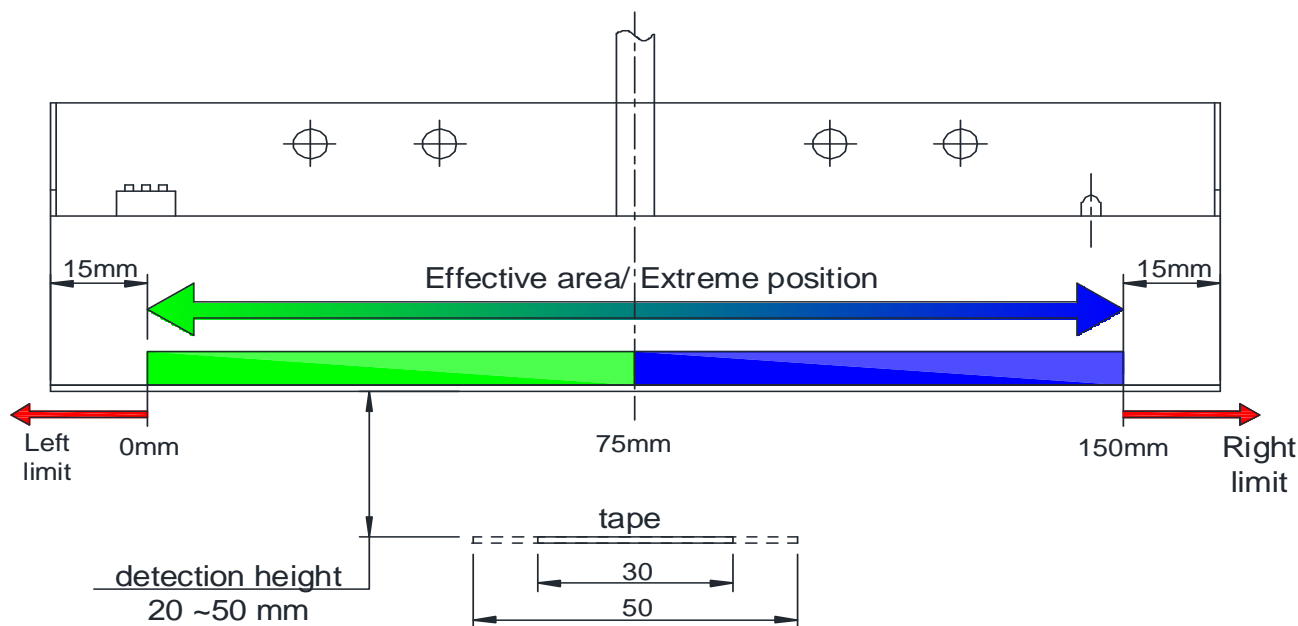

AGV-TMR250V (analog voltage output)

AGV Magnetic Guide Sensors

DIP SWITCH OPERATING MODES

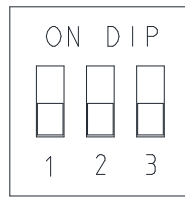

0	0	0
1	1	1

Operating Modes	Dialing Logic	LED indicator
N/S pole	000	red/green LED alternating blink, low rate
N pole only	100	red LED stay lit constantly
S pole only	010	green LED stay lit constantly
Zero field calibration	XX1	high rate alternating blink during calibration, off when completed

Note

1. Keep any magnetic materials at least 50 mm away from AGV sensor detection surface during calibration
2. Switch the third digit back to zero to enter the normal operation mode after calibration

DIMENSIONS (mm)

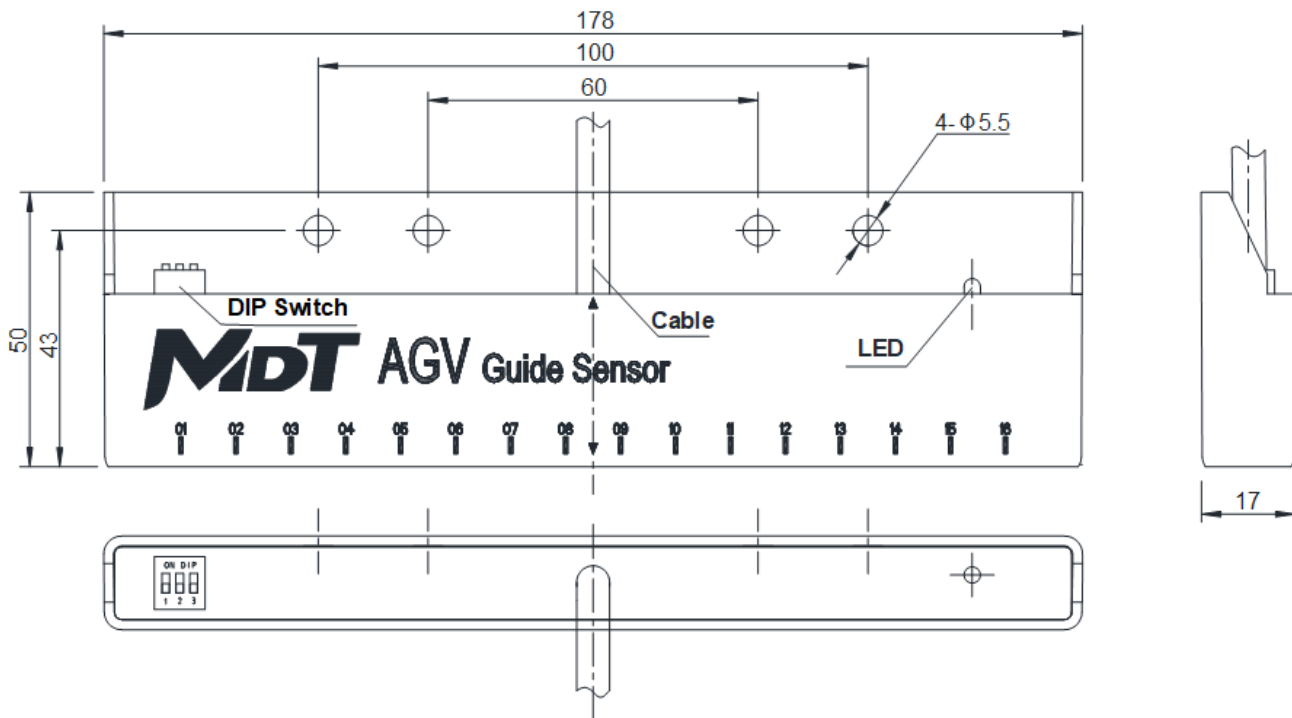

AGV-TMR250V (analog voltage output)

AGV Magnetic Guide Sensors

CONNECTION CONFIGURATION INSTRUCTIONS

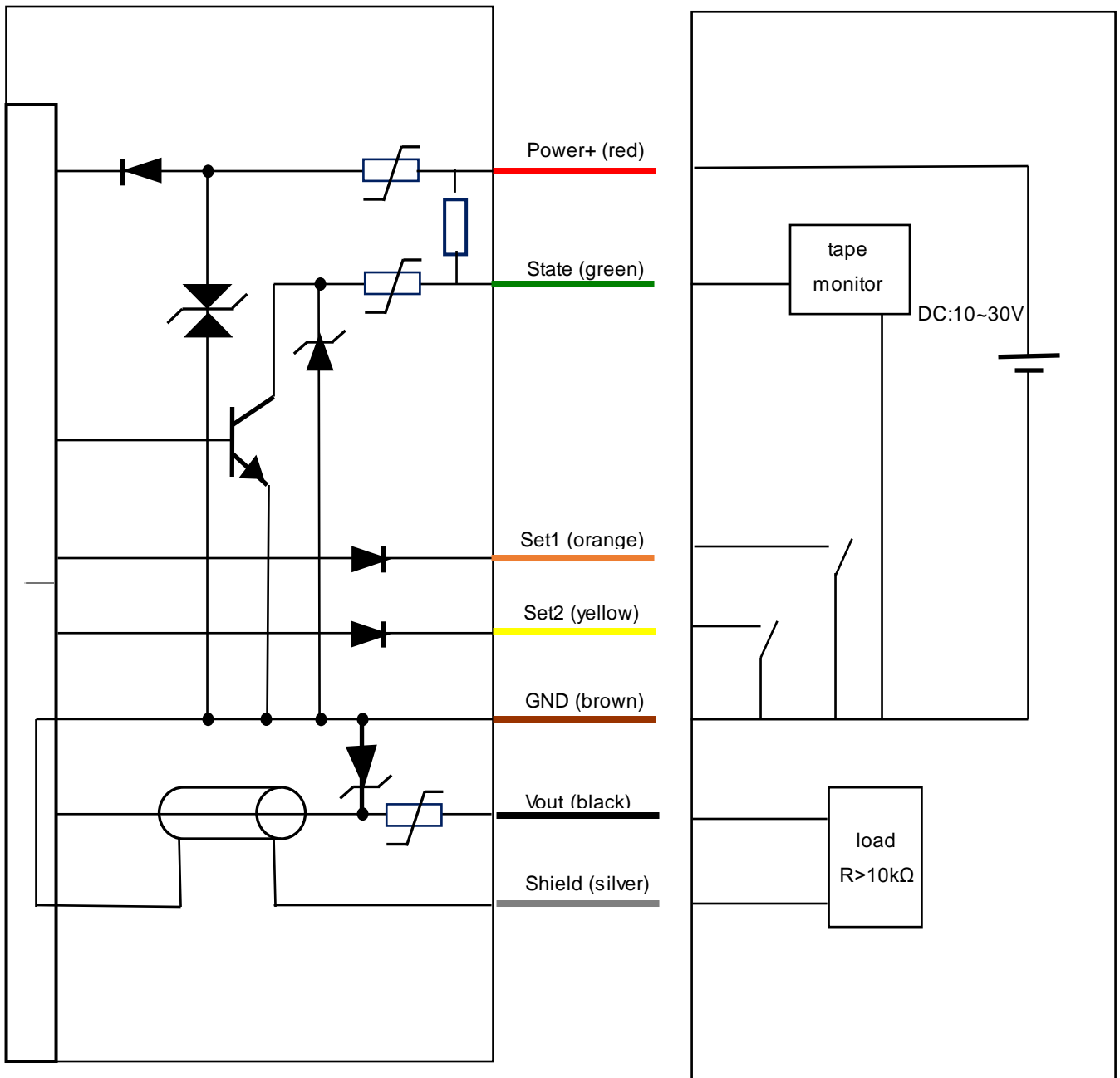

MODE	Not selected	Straight	Right branch	Left branch
SET1	H	L	L	H
SET2	H	L	H	L

AGV-TMR250V (analog voltage output)

AGV Magnetic Guide Sensors

OUTPUT SIGNAL

(1) Straight Mode

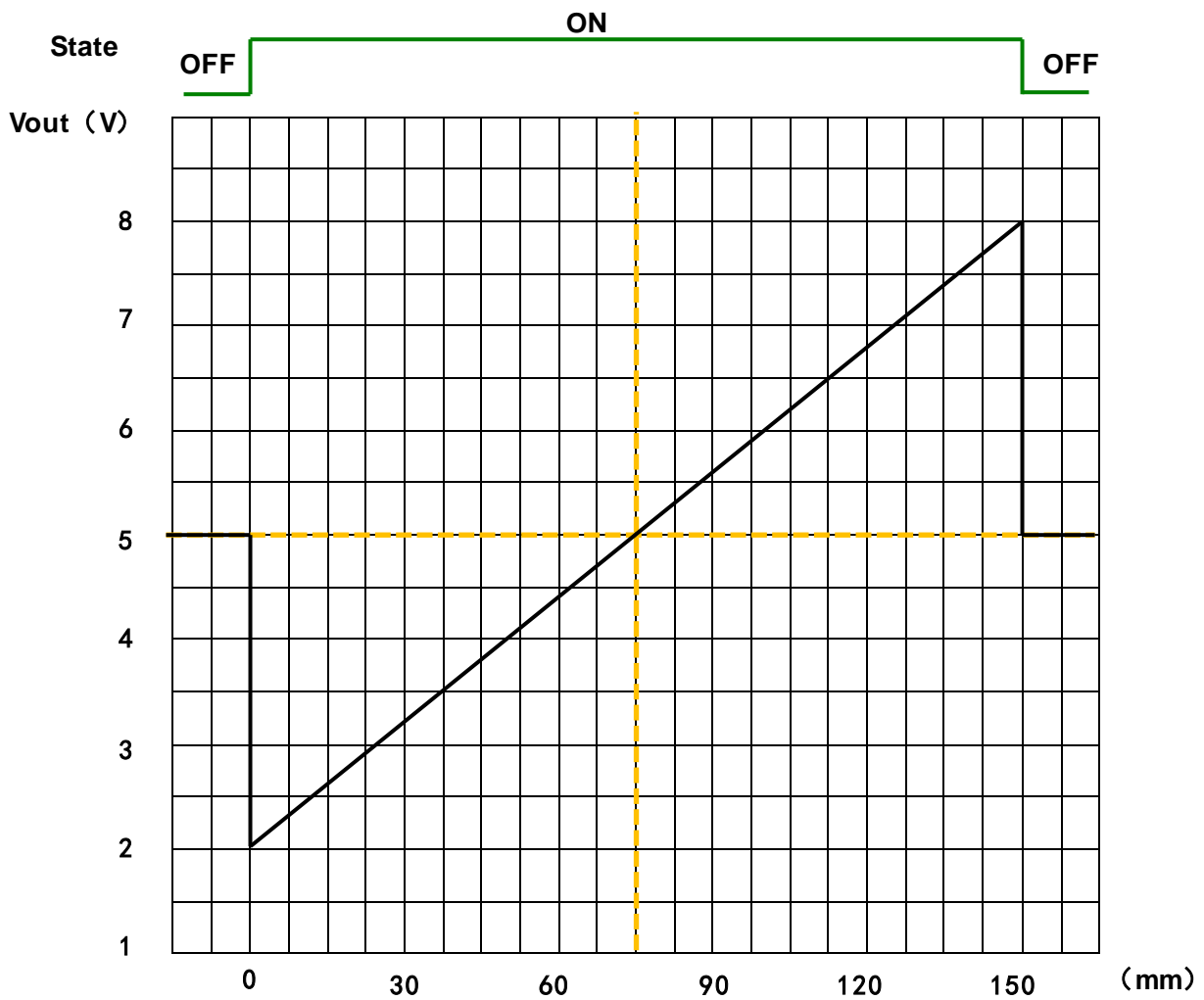
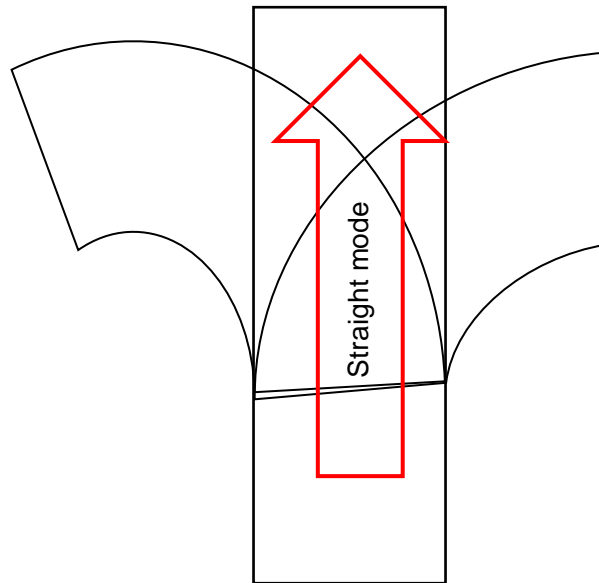

AGV-TMR250V (analog voltage output)

AGV Magnetic Guide Sensors

(2) left branch mode

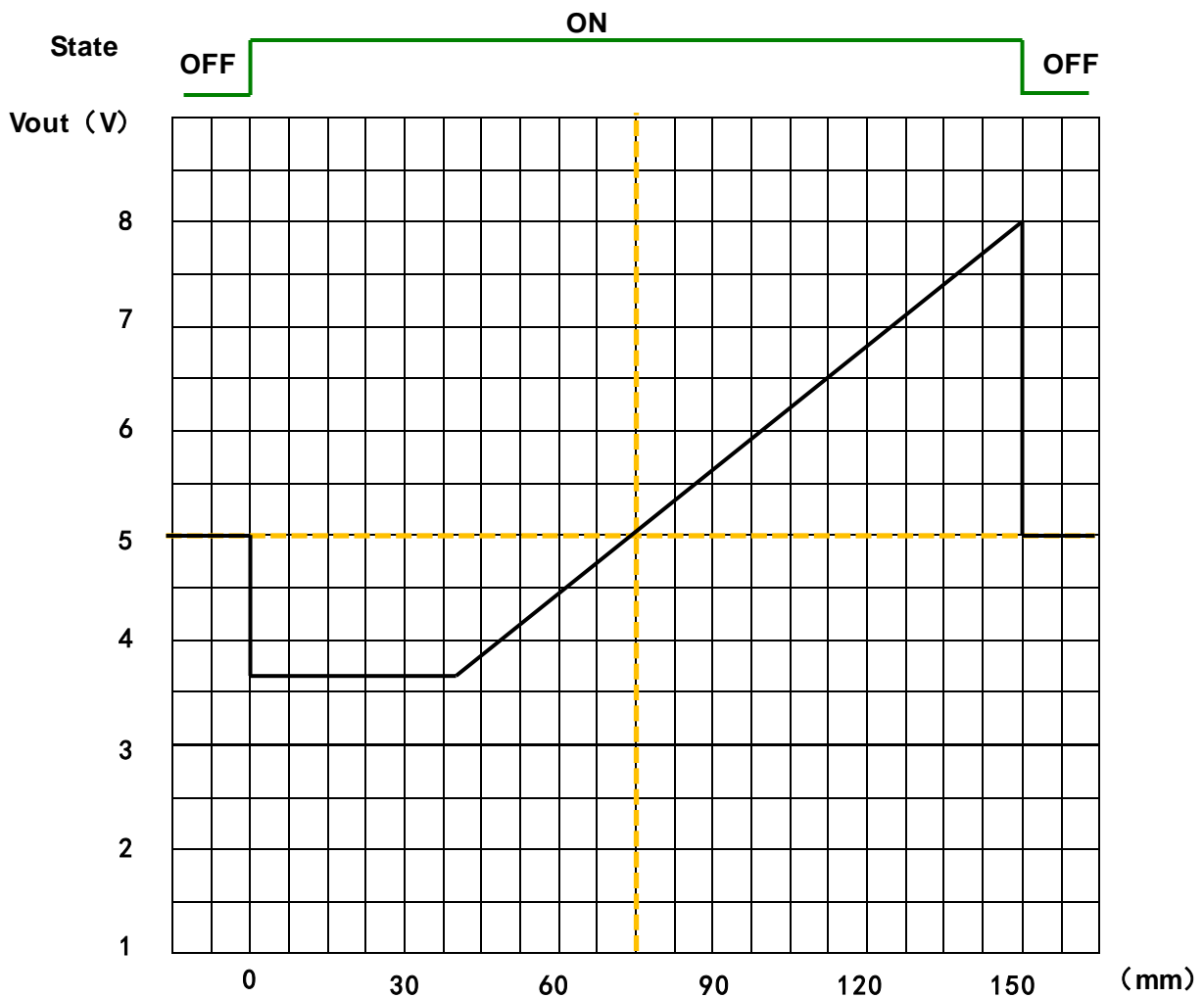
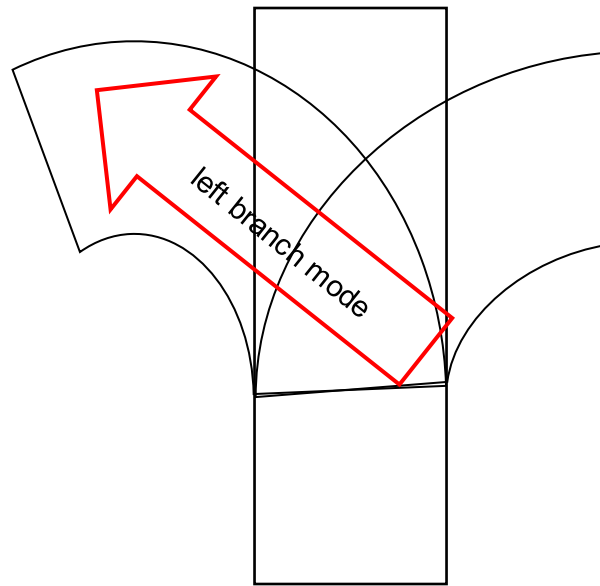

AGV-TMR250V (analog voltage output)

AGV Magnetic Guide Sensors

(3) right branch mode

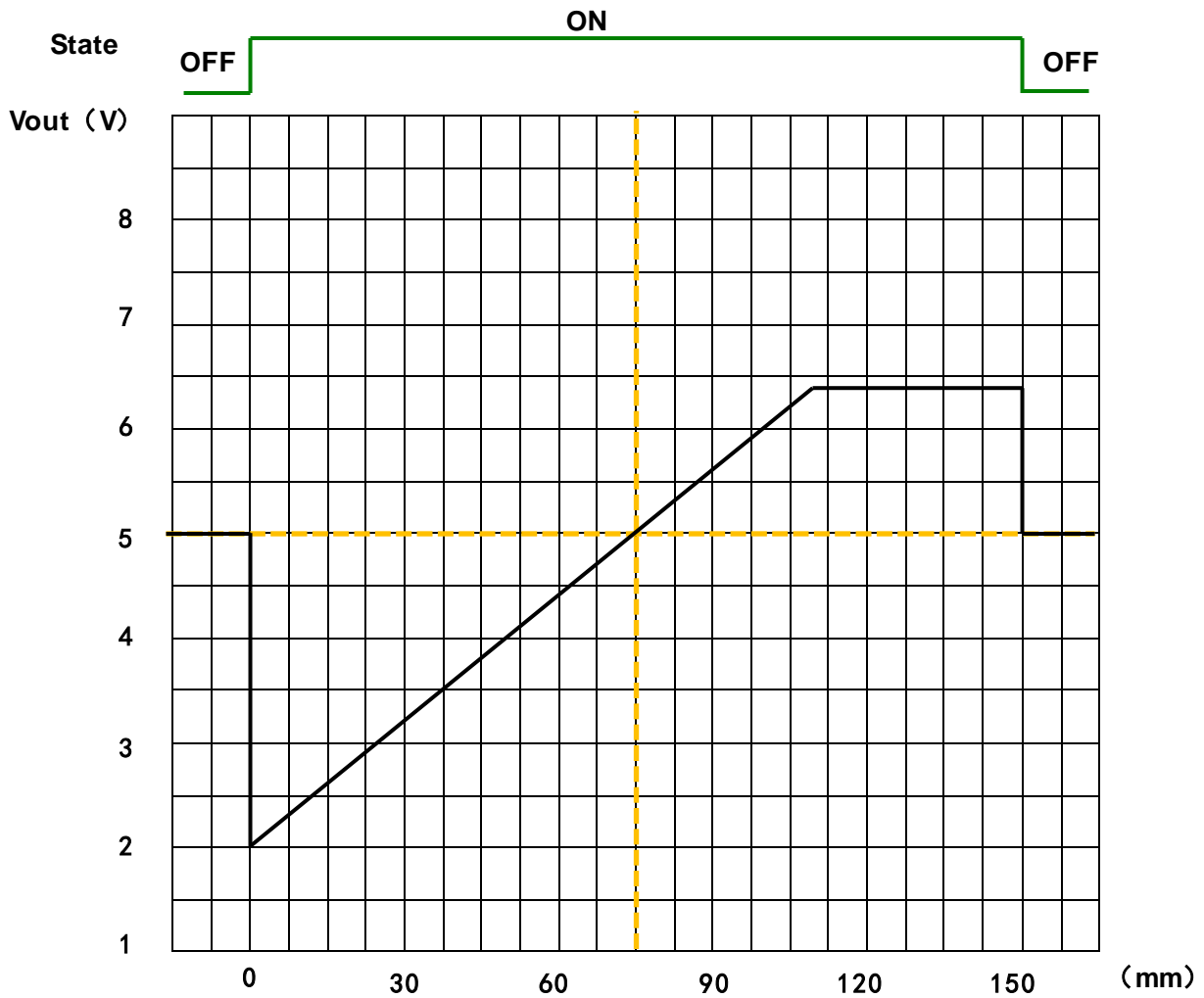
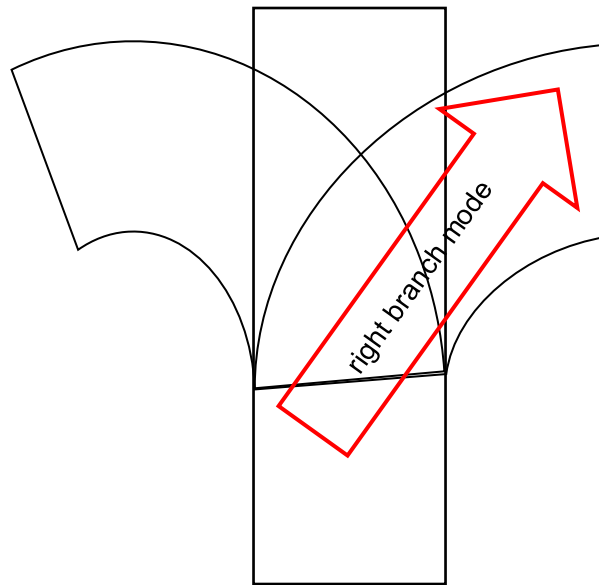

AGV-TMR250V (analog voltage output)

AGV Magnetic Guide Sensors



The information provided herein by MultiDimension Technology Co., Ltd.(hereinafter MultiDimension) is believed to be accurate and reliable. Publication neither conveys nor implies any license under patent or other industrial or intellectual property rights. MultiDimension reserves the right to make changes to product specifications for the purpose of improving product quality, reliability, and functionality. MultiDimension does not assume any liability arising out of the application and use of its products. MultiDimension's customers using or selling this product for use in appliances, devices, or systems where malfunction can reasonably be expected to result in personal injury do so at their own risk and agree to fully indemnify MultiDimension for any damages resulting from such applications.

MultiDimension Technology Co., Ltd.

No.7 Guangdong Road, Zhangjiagang Free Trade Zone

Jiangsu, 215634, China

www.dowaytech.com/en

info@dowaytech.com

