



MB39C022G-EVB01 1CH Buck DC/DC Converter and 1CH LDO IC

## Evaluation Kit User Guide

Doc. No. 002-18231 Rev. \*\*

Cypress Semiconductor  
198 Champion Court  
San Jose, CA 95134-1709  
Phone (USA): 800.858.1810  
Phone (Intl): +1.408.943.2600  
[www.cypress.com](http://www.cypress.com)

## Copyrights

© Cypress Semiconductor Corporation, 2016. This document is the property of Cypress Semiconductor Corporation and its subsidiaries, including Spansion LLC ("Cypress"). This document, including any software or firmware included or referenced in this document ("Software"), is owned by Cypress under the intellectual property laws and treaties of the United States and other countries worldwide. Cypress reserves all rights under such laws and treaties and does not, except as specifically stated in this paragraph, grant any license under its patents, copyrights, trademarks, or other intellectual property rights. If the Software is not accompanied by a license agreement and you do not otherwise have a written agreement with Cypress governing the use of the Software, then Cypress hereby grants you a personal, non-exclusive, nontransferable license (without the right to sublicense) (1) under its copyright rights in the Software (a) for Software provided in source code form, to modify and reproduce the Software solely for use with Cypress hardware products, only internally within your organization, and (b) to distribute the Software in binary code form externally to end users (either directly or indirectly through resellers and distributors), solely for use on Cypress hardware product units, and (2) under those claims of Cypress's patents that are infringed by the Software (as provided by Cypress, unmodified) to make, use, distribute, and import the Software solely for use with Cypress hardware products. Any other use, reproduction, modification, translation, or compilation of the Software is prohibited.

TO THE EXTENT PERMITTED BY APPLICABLE LAW, CYPRESS MAKES NO WARRANTY OF ANY KIND, EXPRESS OR IMPLIED, WITH REGARD TO THIS DOCUMENT OR ANY SOFTWARE OR ACCOMPANYING HARDWARE, INCLUDING, BUT NOT LIMITED TO, THE IMPLIED WARRANTIES OF MERCHANTABILITY AND FITNESS FOR A PARTICULAR PURPOSE. To the extent permitted by applicable law, Cypress reserves the right to make changes to this document without further notice. Cypress does not assume any liability arising out of the application or use of any product or circuit described in this document. Any information provided in this document, including any sample design information or programming code, is provided only for reference purposes. It is the responsibility of the user of this document to properly design, program, and test the functionality and safety of any application made of this information and any resulting product. Cypress products are not designed, intended, or authorized for use as critical components in systems designed or intended for the operation of weapons, weapons systems, nuclear installations, life-support devices or systems, other medical devices or systems (including resuscitation equipment and surgical implants), pollution control or hazardous substances management, or other uses where the failure of the device or system could cause personal injury, death, or property damage ("Unintended Uses"). A critical component is any component of a device or system whose failure to perform can be reasonably expected to cause the failure of the device or system, or to affect its safety or effectiveness. Cypress is not liable, in whole or in part, and you shall and hereby do release Cypress from any claim, damage, or other liability arising from or related to all Unintended Uses of Cypress products. You shall indemnify and hold Cypress harmless from and against all claims, costs, damages, and other liabilities, including claims for personal injury or death, arising from or related to any Unintended Uses of Cypress products.

Cypress, the Cypress logo, Spansion, the Spansion logo, and combinations thereof, WICED, PSoC, CapSense, EZ-USB, F-RAM, and Traveo are trademarks or registered trademarks of Cypress in the United States and other countries. For a more complete list of Cypress trademarks, visit [cypress.com](http://cypress.com). Other names and brands may be claimed as property of their respective owners.

# Contents



<b>Safety Information</b> .....	<b>4</b>
Regulatory Compliance .....	4
General Safety Instructions .....	4
<b>1. Introduction</b> .....	<b>5</b>
1.1 Kit Contents .....	5
<b>2. Kit Overview</b> .....	<b>6</b>
2.1 Terminal Information .....	6
2.2 Specification .....	6
2.3 Hardware .....	7
2.4 Default Settings .....	7
<b>3. Set Up and Check</b> .....	<b>8</b>
3.1 Setup and Check .....	8
<b>4. Reference Data</b> .....	<b>9</b>
4.1 Reference Data .....	9
<b>Appendix</b> .....	<b>12</b>
A.1 Schematic .....	12
A.2. Bill of Materials (BOM) .....	13
A.3 Image .....	14
A.4 Silk Screen .....	14
A.5 Layout .....	15
<b>Revision History</b> .....	<b>16</b>
Document Revision History .....	16

# Safety Information



## Regulatory Compliance

This Evaluation Kit is intended for use as a development platform for hardware in a laboratory environment. The board is an open system design, which does not include a shielded enclosure. This may cause interference to other electrical or electronic devices in close proximity.

In a domestic environment, this product may cause radio interference. The user may then be required to take adequate prevention measures. Also, the board should not be used near any medical equipment or RF devices.

Attaching additional wiring to this product or modifying the product operation from the factory default may affect its performance and cause interference with other apparatus in the immediate vicinity. If such interference is detected, suitable mitigating measures should be taken.



This Evaluation Kit contains electrostatic discharge (ESD) sensitive devices. Electrostatic charges readily accumulate on the human body and any equipment, and can discharge without detection. Permanent damage may occur on devices subjected to high-energy discharges. Proper ESD precautions are recommended to avoid performance degradation or loss of functionality. Store unused this board in the protective shipping package.

## General Safety Instructions

### ESD Protection

ESD can damage boards and associated components. Cypress recommends that you perform procedures only at an ESD workstation. If an ESD workstation is not available, use appropriate ESD protection by wearing an antistatic wrist strap attached to chassis ground (any unpainted metal surface) on your board when handling parts.

### Handling Boards

This board is sensitive to ESD. Hold the board only by its edges. After removing the board from its box, place it on a grounded, static-free surface. Use a conductive foam pad if available. Do not slide board over any surface.

# 1. Introduction



Thank you for your interest in the MB39C022G-EVB01 1CH Buck DC/DC Converter and 1CH LDO IC Evaluation Kit (EVK). The kit is designed as an easy-to-use evaluation kit, showcasing the features of the Cypress MB39C022G-EVB01 1CH Buck DC/DC Converter that has fast transient response and 1CH LDO IC has low noise output. For more information, see [the MB39C022G data-sheet](#).

## 1.1 Kit Contents

This evaluation kit includes the following items as shown in [Figure 1-1](#):

- MB39C022G-EVB01 evaluation board
- Quick start guide ([www.cypress.com/MB39C022G-EVB01](http://www.cypress.com/MB39C022G-EVB01))

Figure 1-1. MB39C022G-EVB01 Evaluation Kit Contents

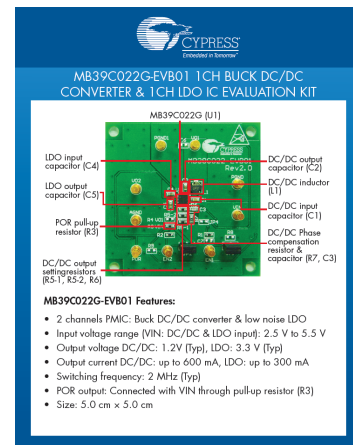
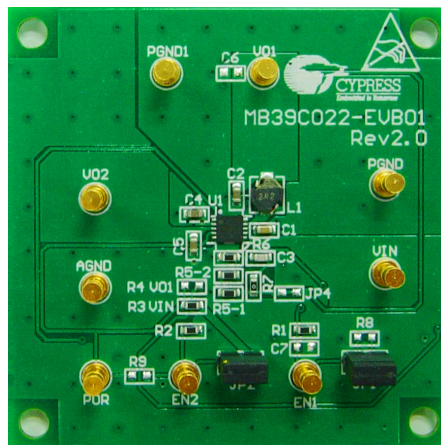

## 2. Kit Overview



### 2.1 Terminal Information

Terminal Name	I/O	Descriptions
VIN	I	Input power supply terminal
EN1	I	Ch1 DC/DC control terminal EN1 = LOW: VO1 and POR output off EN1 = HIGH: VO1 and POR output on
EN2	I	Ch2 LDO control terminal EN2 = LOW: VO2 output off EN2 = HIGH: VO2 output on
VO1	O	Ch1 DC/DC converter output terminal
VO2	O	Ch2 LOD output terminal
POR	O	Power-on-reset output terminal
PGND	-	Power ground terminal
PGND1	-	Power ground terminal
AGND	-	Analog ground terminal

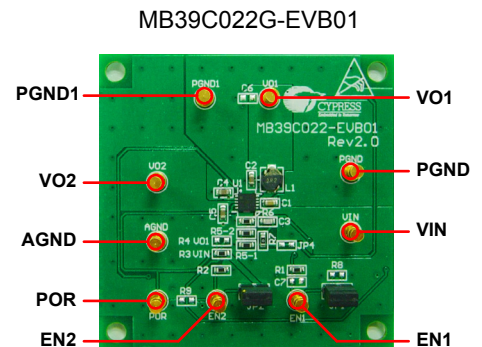

### 2.2 Specification

Parameter			Value			Unit
			Min	Typ	Max	
Input voltage	Ch1, Ch2	VIN	3.5	3.7	5.5	V
	Ch1	VO1	0.8	1.2	4.5	V
Output voltage	Ch2	VO2	3.23	3.3	3.36	V
	Ch1	I <sub>O1</sub>	0	-	0.6	A
Output current	Ch2	I <sub>O2</sub>	0	-	0.3	A
	Ch1, Ch2	-	-	500	-	kHz

The output voltage of VO1 can be set by the external resistors, see [2.4 Default Settings](#). The applied voltage of VIN should be between the voltage 0.5 V higher than the VO1 setting voltage and 5.5 V.

## 2.3 Hardware

The kit consists of the following components as shown in Figure 2-1:

Figure 2-1. Kit Components

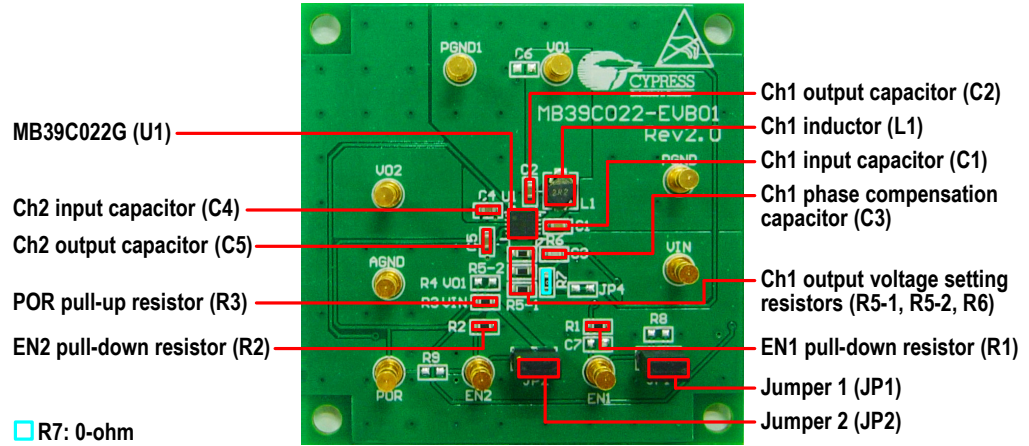

## 2.4 Default Settings

### 1. Output voltage

$$VO1 = \frac{(R5-1 + R5-2) + R6}{R6} \times 0.3 = \frac{(300k + 300k) + 200k}{200k} \times 0.3 \approx 1.2 \text{ [V]}$$

$$VO2 = 3.3 \text{ [V] (Preset)}$$

## 3. Set Up and Check



### 3.1 Setup and Check

Figure 3-1. Terminals for Setup and Check

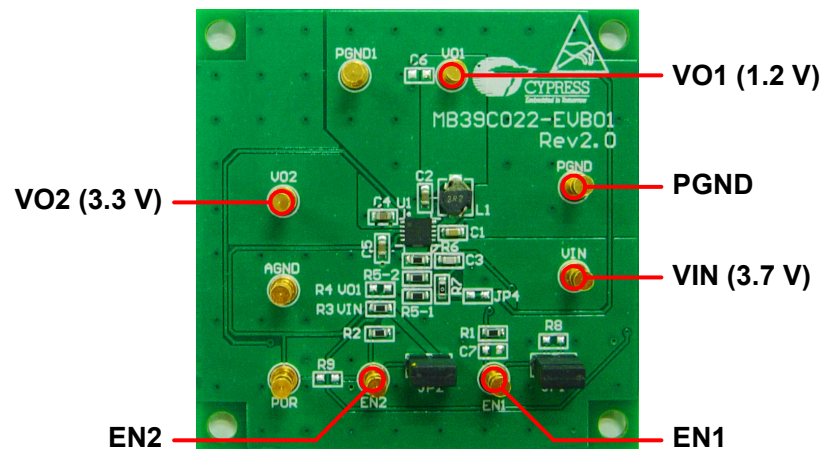

#### Setup\*

1. Connect VIN to a power supply and PGND to the ground.
2. Connect EN1 and EN2 to VIN.
3. Connect VO1 to a voltmeter.
4. Connect VO2 to a voltmeter.

#### Check\*

1. Apply 3.7 V to VIN.
2. VO1 voltage (DC/DC output) should be 1.2 V (typ) and VO2 voltage (LDO output) should be 3.3 V (typ)

\*Do not supply power to VIN until settings are completed.



# 4. Reference Data



## 4.1 Reference Data

Figure 4-1. Reference Data

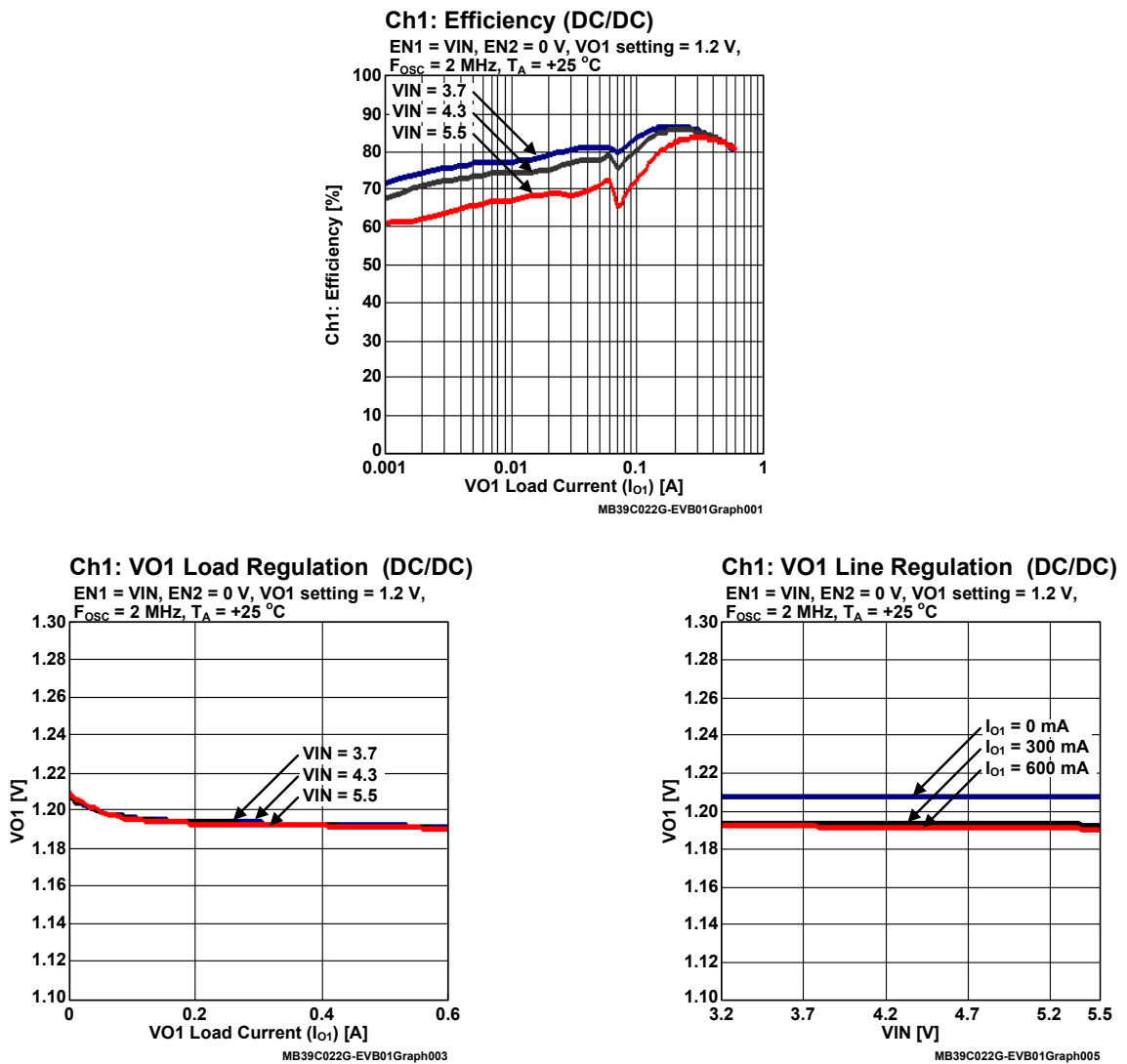

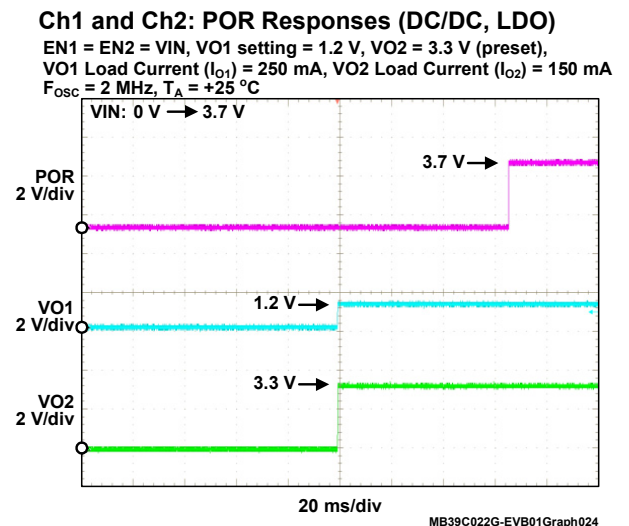
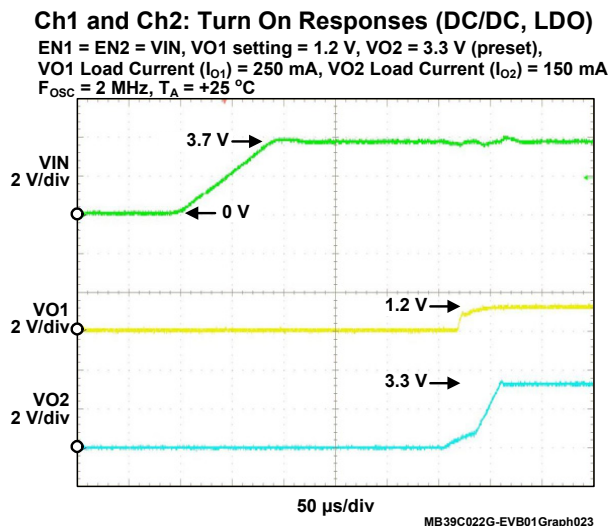
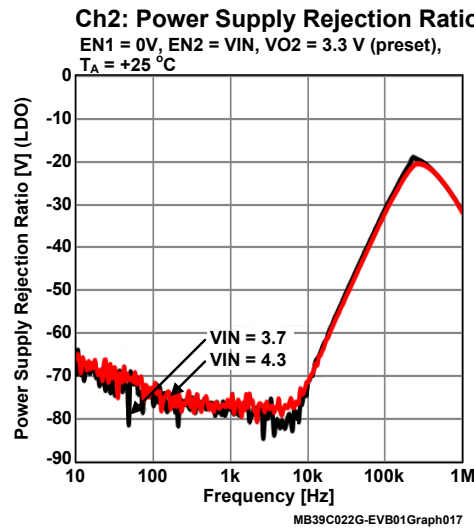
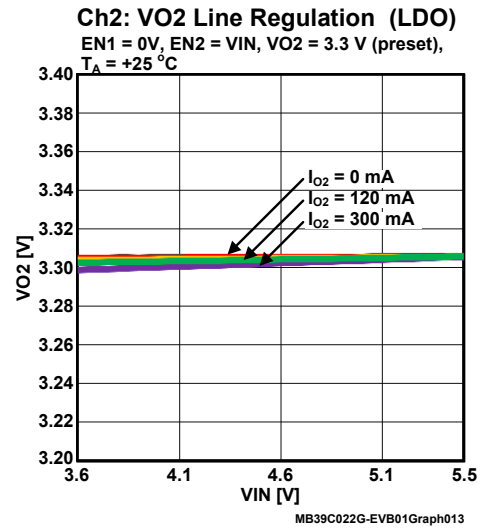
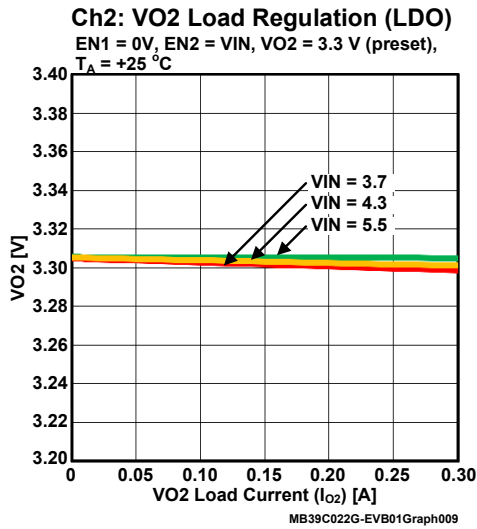

**Ch1: VO1 Load Transient Response (DC/DC)**

VIN = EN1 = EN2 = 3.7 V, VO1 setting = 1.2 V, VO2 = 3.3 V (preset),  
VO2 load current ( $I_{O2}$ ) = 150 mA,  $F_{osc}$  = 2 MHz,  $T_A$  = +25 °C

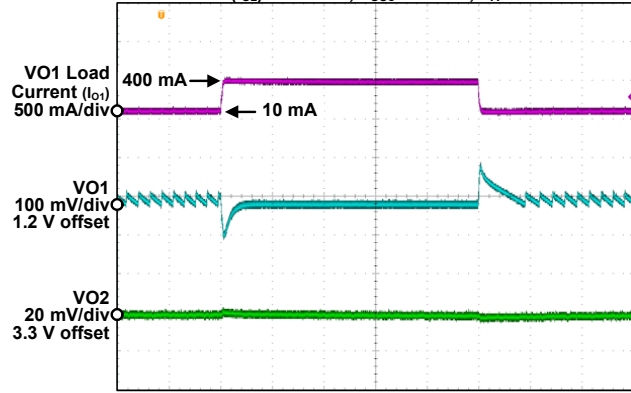

100  $\mu$ s/div

MB39C022G-EVB01 Graph021

**Ch2: VO2 Load Transient Response (LDO)**

VIN = EN1 = EN2 = 3.7 V, VO1 setting = 1.2 V, VO2 = 3.3 V (preset),  
VO1 load current ( $I_{O1}$ ) = 250 mA,  $F_{osc}$  = 2 MHz,  $T_A$  = +25 °C

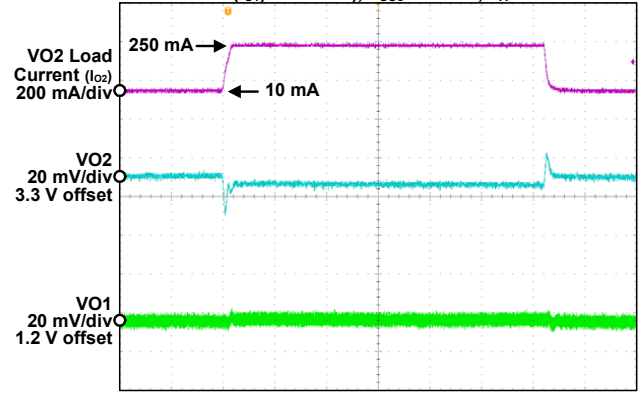

40  $\mu$ s/div

MB39C022G-EVB01 Graph022

# Appendix



## A.1 Schematic

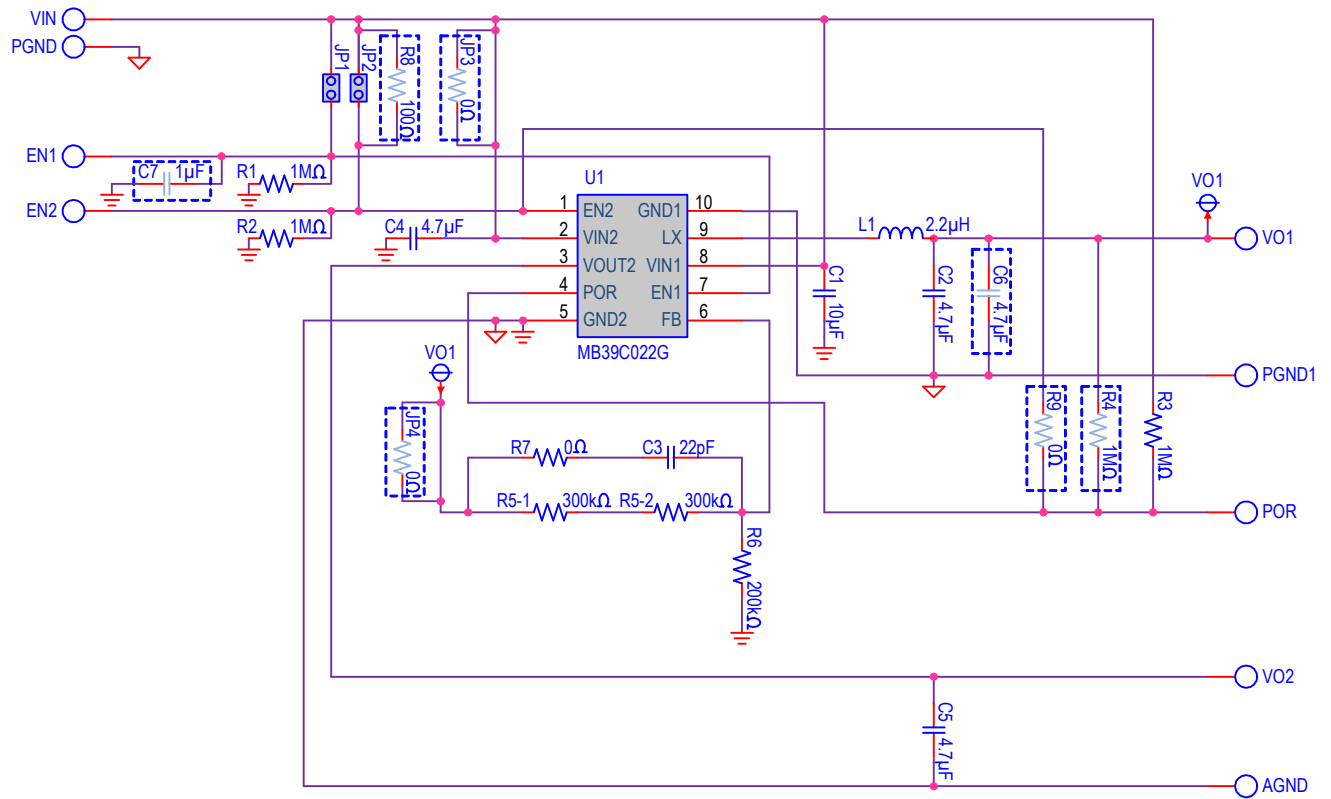

: Non-mounted component

## A.2. Bill of Materials (BOM)

No	Symbol	Item	Value / Description	Part Number	Vendor	PKG / Size	Remark
1	U1	IC	1ch buck DC/DC and 1ch LDO	MB39C022GPN-G-ERE1	Cypress	SON10	–
2	L1	Inductor	2.2 $\mu$ H (87 m $\Omega$ , 1.5A)	VLF4012AT-2R2M1R5	TDK	3.7 $\times$ 3.5 $\times$ 1.2 (mm)	–
3	C1	Capacitor	10 $\mu$ F (6.3 V, JB)	C1608JB0J106M	TDK	0603	–
4	C2, C4, C5	Capacitor	4.7 $\mu$ F (10 V, JB)	C1608JB1A475K	TDK	0603	–
5	C3	Capacitor	22 pF (50 V, CH)	C1608CH1H220J	TDK	0603	–
5	C6	Capacitor	4.7 $\mu$ F (10 V, JB)	–	–	0603	No mount
17	R1, R2, R3	Resistor	1 M $\Omega$ (1/10 W, 1 %)	MCR03ERTF1004	Rohm	0603	–
	R4	Resistor	1 M $\Omega$	–	–	0603	No mount
7	R5-1, R5-2	Resistor	300 k $\Omega$ (1/10 W, 1 %)	MCR03ERTF3003	Rohm	0603	–
17	R7	Resistor	0 $\Omega$ (1/10 W)	MCR03EZPJ000	Rohm	0603	–
18	R6	Resistor	200 k $\Omega$ (1/10 W, 1 %)	MCR03ERTF2003	Rohm	0603	–
	R8	Resistor	100 $\Omega$	–	–	0603	No mount
	R9	Resistor	0 $\Omega$	–	–	0603	No mount
20	JP1, JP2	Jumper pin	2 pin	PRPC002SAAN-RC	Sullins Connector Solutions	–	–
20	JP3, JP4	Resistor	0 $\Omega$	–	–	0603	No mount
22	PIN	Terminal	Wire wrap	WT-2-1	Mac-Eight	–	–

### A.3 Image

Figure 5-1. Image

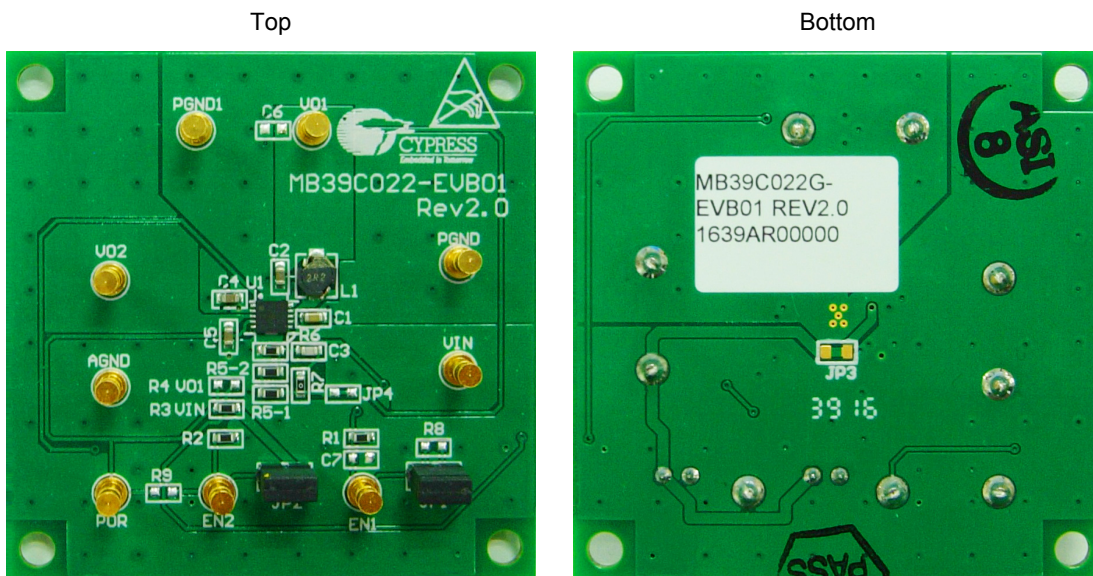

### A.4 Silk Screen

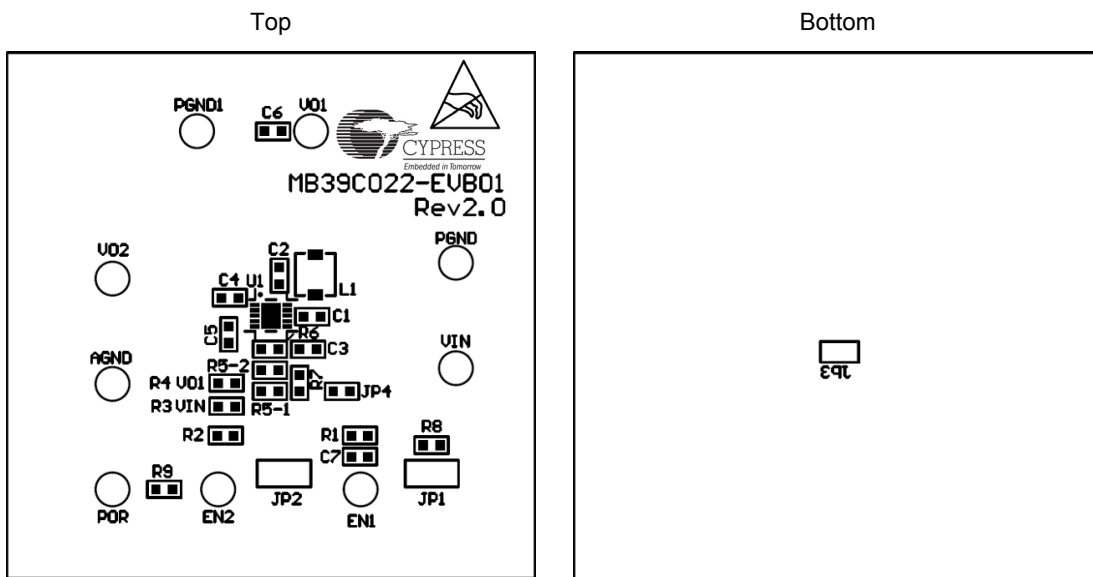

## A.5 Layout

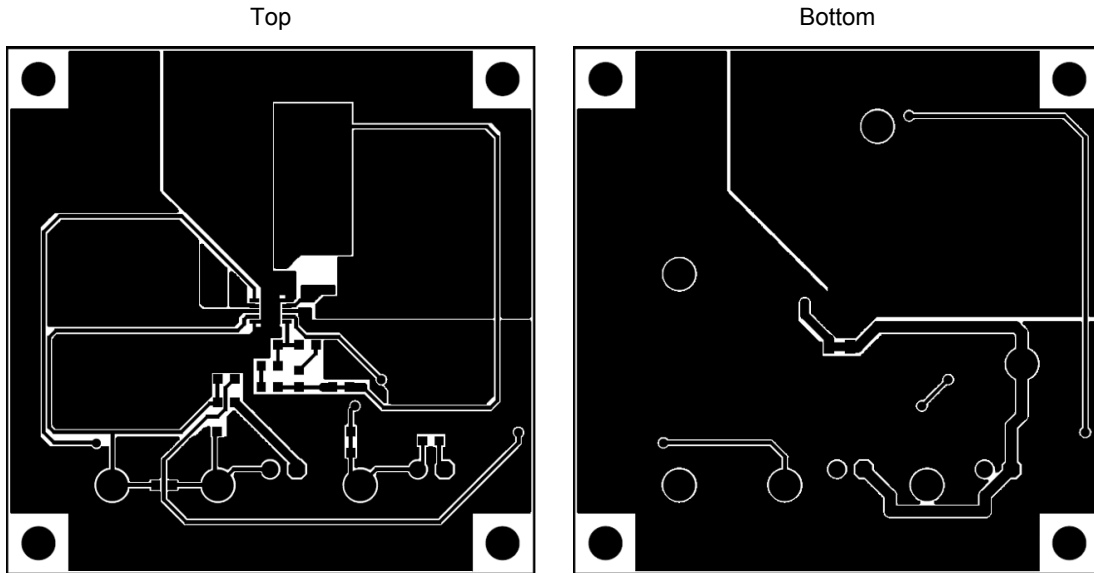

# Revision History



## Document Revision History

<b>Document Title: MB39C022G-EVB01 1CH Buck DC/DC Converter and 1CH LDO IC Evaluation Kit User Guide</b>				
<b>Document Number: 002-18231</b>				
Revision	ECN#	Issue Date	Origin of Change	Description of Change
**	5570973	12/31/2016	HIXT	New user guide