

# CS8156

## 12 V, 5.0 V Low Dropout Dual Regulator with ENABLE

The CS8156 is a low dropout 12 V/5.0 V dual output linear regulator. The 12 V  $\pm 5.0\%$  output sources 750 mA and the 5.0 V  $\pm 2.0\%$  output sources 100 mA.

The on board ENABLE function controls the regulator's two outputs. When the ENABLE lead is low, the regulator is placed in SLEEP mode. Both outputs are disabled and the regulator draws only 200 nA of quiescent current.

The regulator is protected against overvoltage conditions. Both outputs are protected against short circuit and thermal runaway conditions.

The CS8156 is packaged in a 5 lead TO-220 with copper tab. The copper tab can be connected to a heat sink if necessary.

### Features

- Two Regulated Outputs
  - 12 V  $\pm 5.0\%$ ; 750 mA
  - 5.0 V  $\pm 2.0\%$ ; 100 mA
- Very Low SLEEP Mode Current Drain 200 nA
- Fault Protection
  - Reverse Battery
  - +60 V, -50 V Peak Transient Voltage
  - Short Circuit
  - Thermal Shutdown
- CMOS Compatible ENABLE
- Pb-Free Packages are Available



ON Semiconductor®

<http://onsemi.com>



TO-220  
FIVE LEAD  
T SUFFIX  
CASE 314D

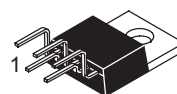

TO-220  
FIVE LEAD  
TVA SUFFIX  
CASE 314K

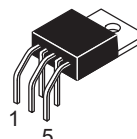

TO-220  
FIVE LEAD  
THA SUFFIX  
CASE 314A

### PIN CONNECTIONS AND MARKING DIAGRAM

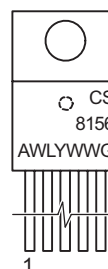

Tab = GND  
Pin 1.  $V_{IN}$   
2.  $V_{OUT1}$   
3. GND  
4. ENABLE  
5.  $V_{OUT2}$

CS8156 = Specific Device Code  
A = Assembly Location  
WL = Wafer Lot  
Y = Year  
WW = Work Week  
G = Pb-Free Package

### ORDERING INFORMATION

See detailed ordering and shipping information in the package dimensions section on page 9 of this data sheet.

\*For additional information on our Pb-Free strategy and soldering details, please download the ON Semiconductor Soldering and Mounting Techniques Reference Manual, SOLDERRM/D.

# CS8156

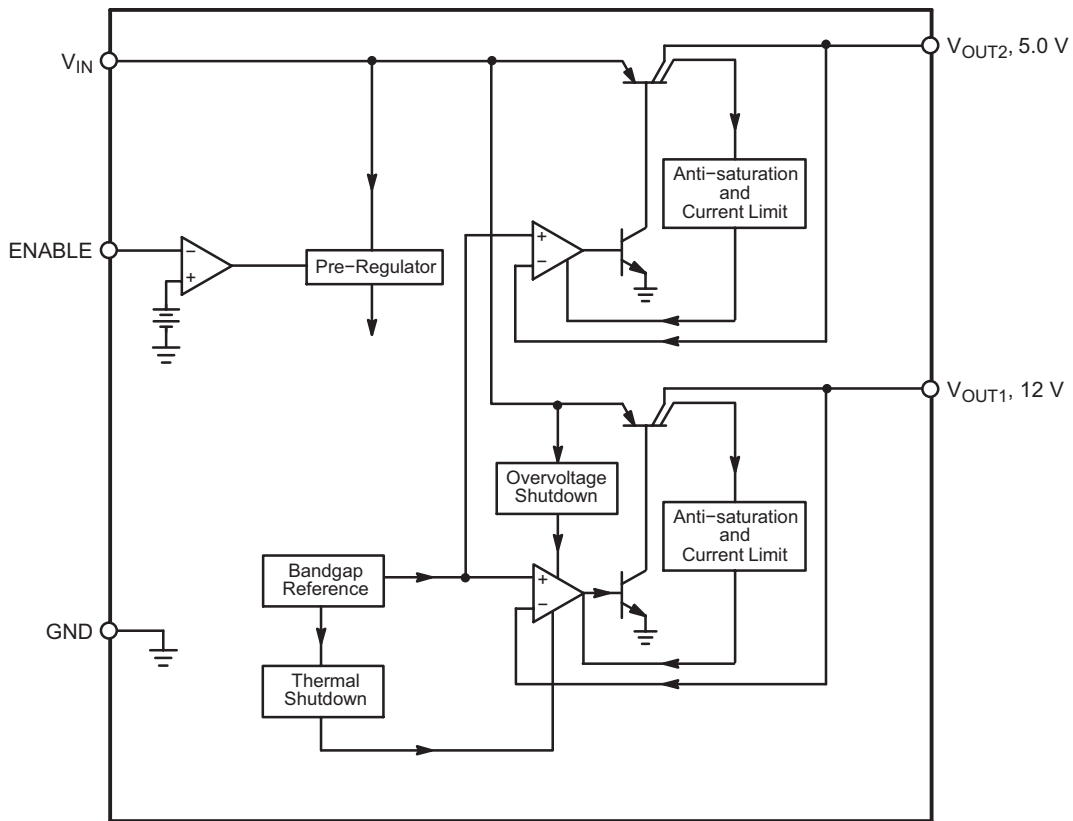

Figure 1. Block Diagram

## ABSOLUTE MAXIMUM RATINGS\*

Rating	Value	Unit
Input Voltage:	Operating Range	-0.5 to 26 V
	Peak Transient Voltage (Note 1)	60 V
Internal Power Dissipation	Internally Limited	-
Operating Temperature Range	-40 to +125	°C
Junction Temperature Range	-40 to +150	°C
Storage Temperature Range	-65 to +150	°C
Lead Temperature Soldering:	Wave Solder (through hole styles only) (Note 2)	260 peak °C

1. Load Dump = 46 V
2. 10 second maximum.

\*The maximum package power dissipation must be observed.

# CS8156

**ELECTRICAL CHARACTERISTICS for  $V_{OUT}$ :** ( $V_{IN} = 14.5\text{ V}$ ,  $I_{OUT1} = 5.0\text{ mA}$ ,  $I_{OUT2} = 5.0\text{ mA}$ ,  $-40^{\circ}\text{C} \leq T_J \leq +150^{\circ}\text{C}$ ,  $-40^{\circ}\text{C} \leq T_C \leq +125^{\circ}\text{C}$ ; unless otherwise specified.)

Characteristic	Test Conditions	Min	Typ	Max	Unit
<b>Output Stage (<math>V_{OUT1}</math>)</b>					
Output Voltage, ( $V_{OUT1}$ )	$13\text{ V} \leq V_{IN} \leq 16\text{ V}$ , $I_{OUT1} \leq 750\text{ mA}$	11.2	12.0	12.8	V
Dropout Voltage	$I_{OUT1} = 500\text{ mA}$ $I_{OUT1} = 750\text{ mA}$	-	0.4	0.6	V
		-	0.6	1.0	V
Line Regulation	$13\text{ V} \leq V_{IN} \leq 16\text{ V}$ , $5.0\text{ mA} \leq I_{OUT1} < 100\text{ mA}$	-	15	80	mV
Load Regulation	$5.0\text{ mA} \leq I_{OUT1} \leq 500\text{ mA}$	-	15	80	mV
Quiescent Current	$I_{OUT1} \leq 500\text{ mA}$ , No Load on Standby $I_{OUT1} \leq 750\text{ mA}$ , No Load on Standby	-	45	125	mA
		-	100	250	mA
Quiescent Current (Sleep Mode)	ENABLE = Low	-	0.2	50	$\mu\text{A}$
Ripple Rejection	$f = 120\text{ Hz}$ , $I_{OUT} = 5.0\text{ mA}$ , $V_{IN} = 1.5\text{ V}_{PP}$ at $15.5\text{ V}_{DC}$	42	70	-	dB
Current Limit	-	0.75	1.20	2.50	A
Maximum Line Transient	$V_{OUT1} \leq 13\text{ V}$	60	90	-	V
Reverse Polarity Input Voltage, DC	$V_{OUT1} \geq -0.6\text{ V}$ , $10\ \Omega$ Load	-18	-30	-	V
Reverse Polarity Input Voltage, Transient	1.0% Duty Cycle, $t = 100\text{ ms}$ , $V_{OUT} \geq -6.0\text{ V}$ , $10\ \Omega$ Load	-50	-80	-	V
Output Noise Voltage	10 Hz – 100 kHz	-	-	500	$\mu\text{V}_{rms}$
Output Impedance	500 mA DC and 10 mA rms, 100Hz	-	0.2	1.0	$\Omega$
Overvoltage Shutdown	-	28	34	45	V

## Standby Output ( $V_{OUT2}$ )

Output Voltage, ( $V_{OUT2}$ )	$9.0\text{ V} \leq V_{IN} \leq 16\text{ V}$ , $1.0\text{ mA} \leq I_{OUT2} \leq 100\text{ mA}$	4.90	5.00	5.10	V
Dropout Voltage	$I_{OUT2} \leq 100\text{ mA}$	-	-	0.60	V
Line Regulation	$6.0\text{ V} \leq V_{IN} \leq 26\text{ V}$ , $1.0\text{ mA} \leq I_{OUT} \leq 100\text{ mA}$	-	5.0	50	mV
Load Regulation	$1.0\text{ mA} \leq I_{OUT2} \leq 100\text{ mA}$ ; $9.0\text{ V} \leq V_{IN} \leq 16\text{ V}$	-	5.0	50	mV
Ripple Rejection	$f = 120\text{ Hz}$ ; $I_{OUT} = 100\text{ mA}$ , $V_{IN} = 1.5\text{ V}_{PP}$ at $14.5\text{ V}_{DC}$	42	70	-	dB
Current Limit	-	100	200	-	mA

## ENABLE Function (ENABLE)

Input ENABLE Threshold	$V_{OUT1}$ Off	-	1.25	0.80	V
	$V_{OUT1}$ On	2.00	1.25	-	V
Input ENABLE Current	$V_{ENABLE} \leq V_{THRESHOLD}$	-10	0	10	$\mu\text{A}$

## PACKAGE PIN DESCRIPTION

PACKAGE LEAD #	LEAD SYMBOL	FUNCTION
5 Lead TO-220		
1	$V_{IN}$	Supply voltage, usually direct from battery.
2	$V_{OUT1}$	Regulated output 12 V, 750 mA (typ).
3	GND	Ground connection.
4	ENABLE	CMOS compatible input lead; switches outputs on and off. When ENABLE is high $V_{OUT1}$ and $V_{OUT2}$ are active.
5	$V_{OUT2}$	Regulated output 5.0 V, 100 mA (typ).

TYPICAL PERFORMANCE CHARACTERISTICS

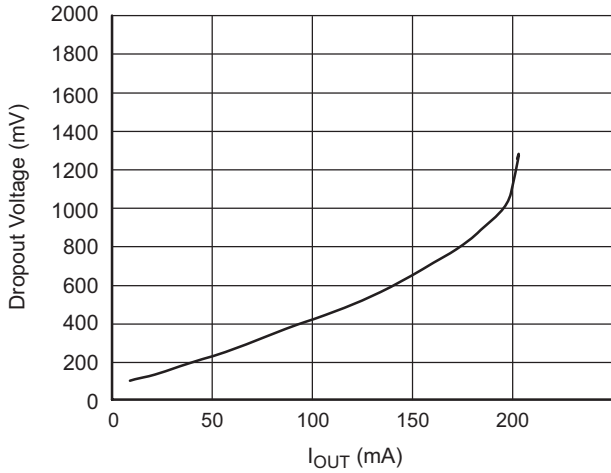

Figure 2. Dropout Voltage vs.  $I_{OUT2}$

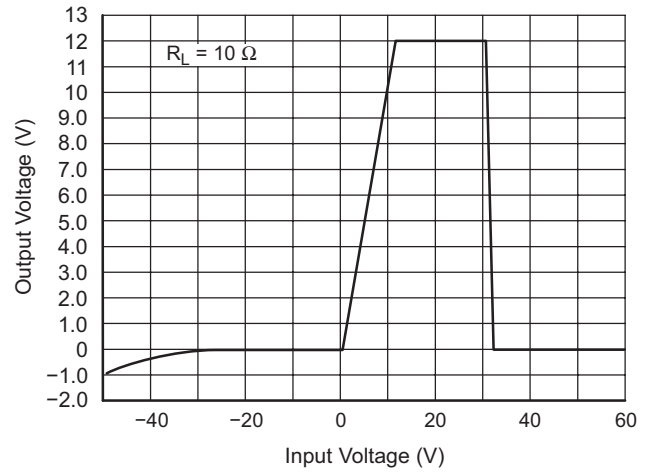

Figure 3.  $V_{OUT1}$  vs. Input Voltage

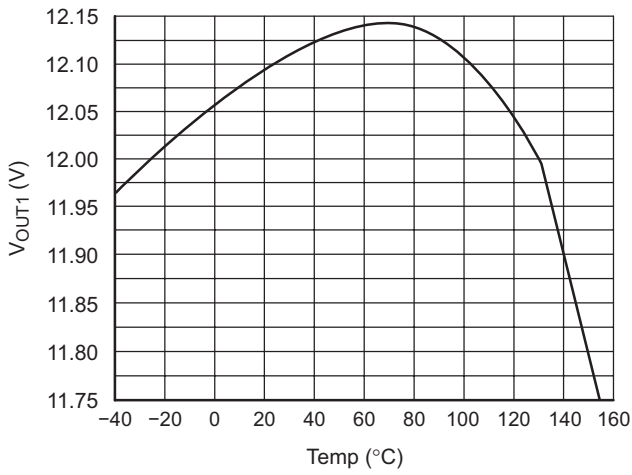

Figure 4.  $V_{OUT1}$  vs. Temperature

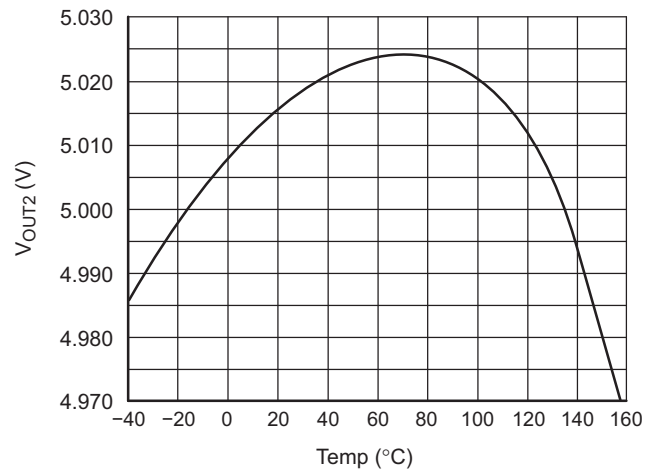

Figure 5.  $V_{OUT2}$  vs. Temperature

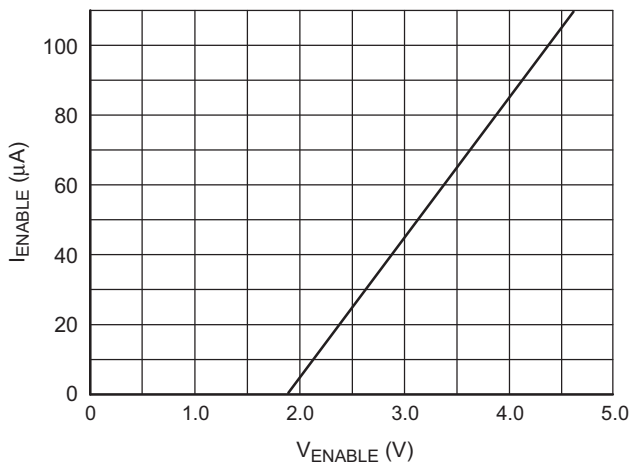

Figure 6. ENABLE Current vs. ENABLE Voltage

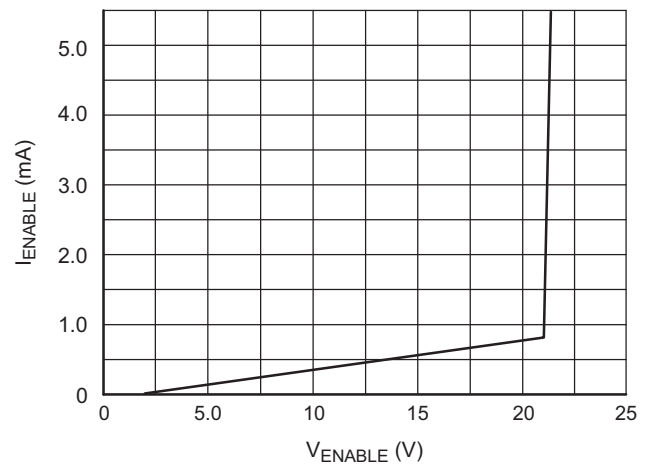

Figure 7. ENABLE Current vs. ENABLE Voltage

TYPICAL PERFORMANCE CHARACTERISTICS (continued)

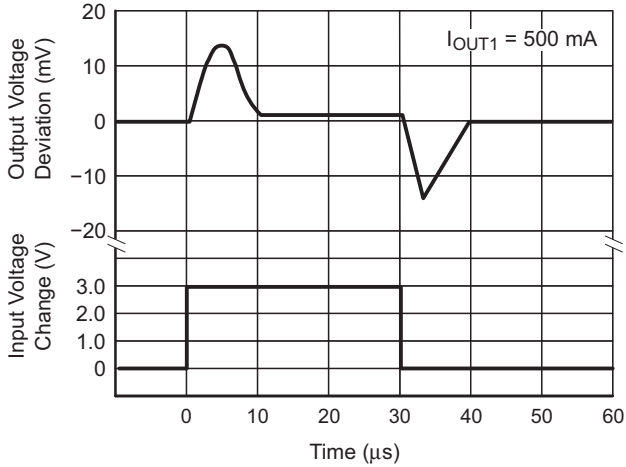

Figure 8. Line Transient Response ( $V_{OUT1}$ )

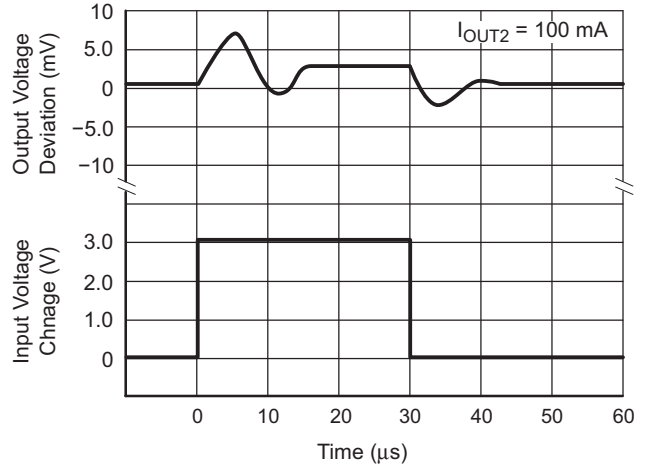

Figure 9. Line Transient Response ( $V_{OUT2}$ )

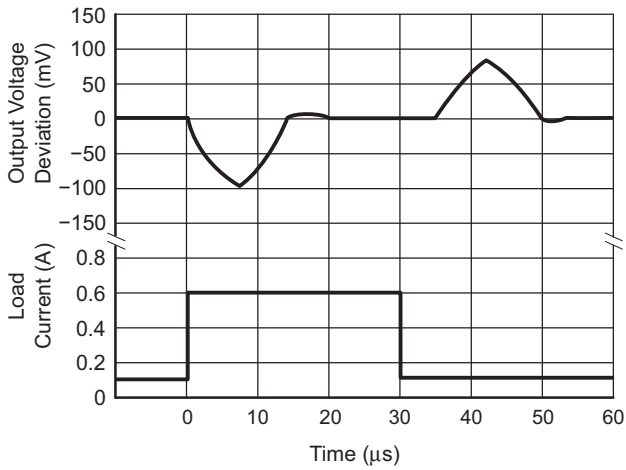

Figure 10. Load Transient Response ( $V_{OUT1}$ )

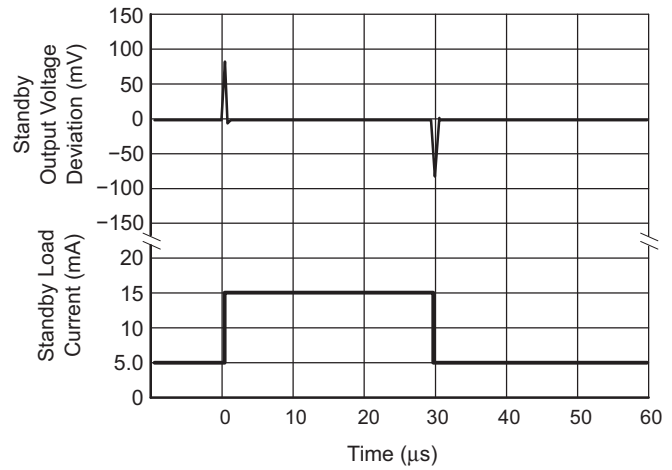

Figure 11. Load Transient Response ( $V_{OUT2}$ )

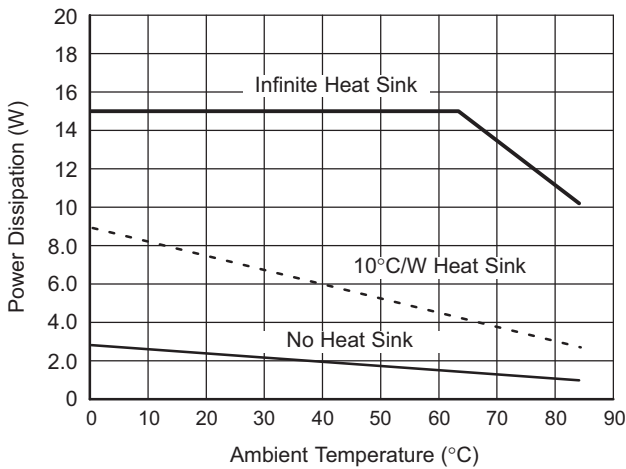

Figure 12. Maximum Power Dissipation (TO-220)

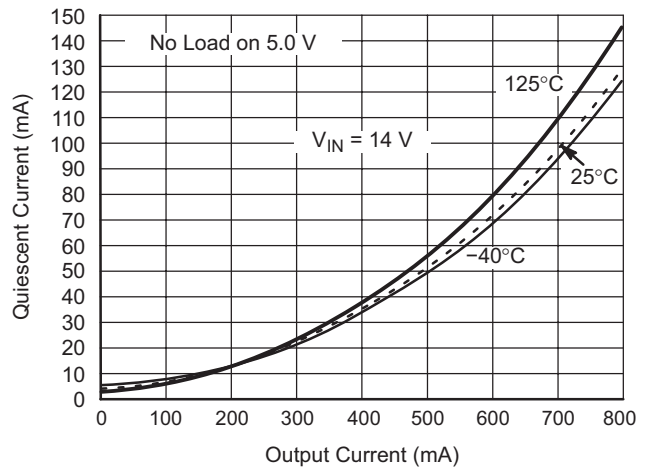

Figure 13. Quiescent Current vs. Output Current for  $V_{OUT2}$

TYPICAL PERFORMANCE CHARACTERISTICS (continued)

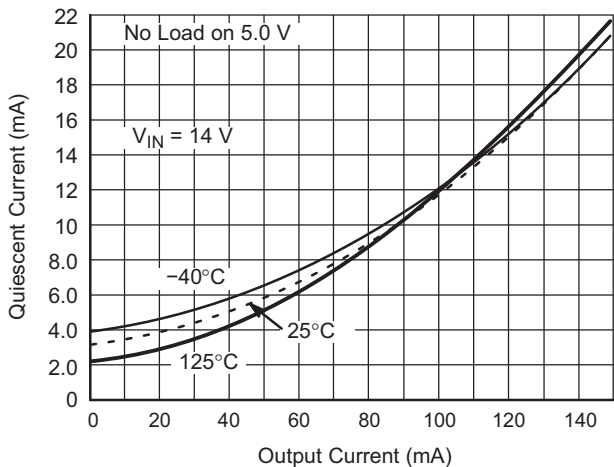

Figure 14. Quiescent Current vs. Output Current for  $V_{OUT1}$

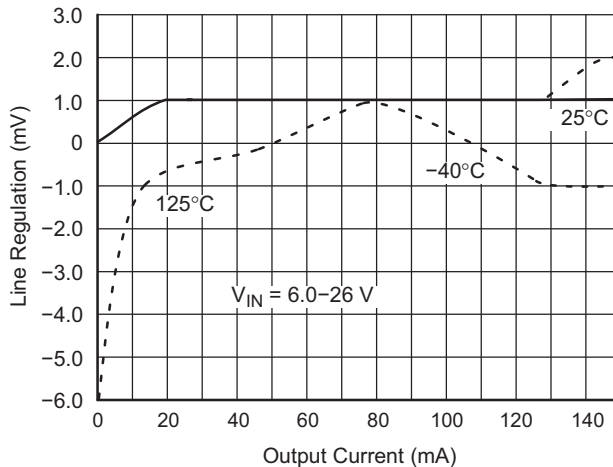

Figure 15. Line Regulation vs. Output Current for  $V_{OUT2}$

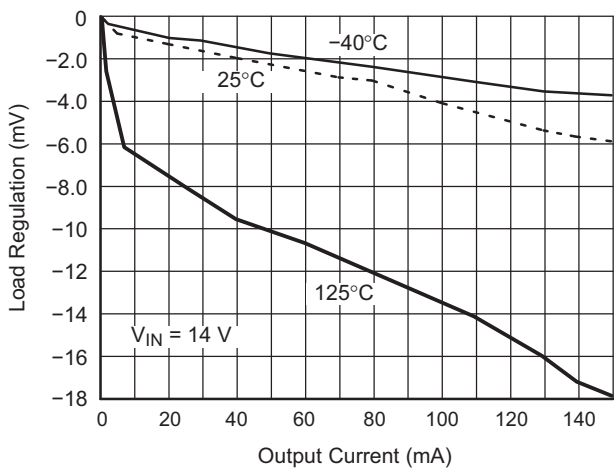

Figure 16. Load Regulation vs. Output Current for  $V_{OUT2}$

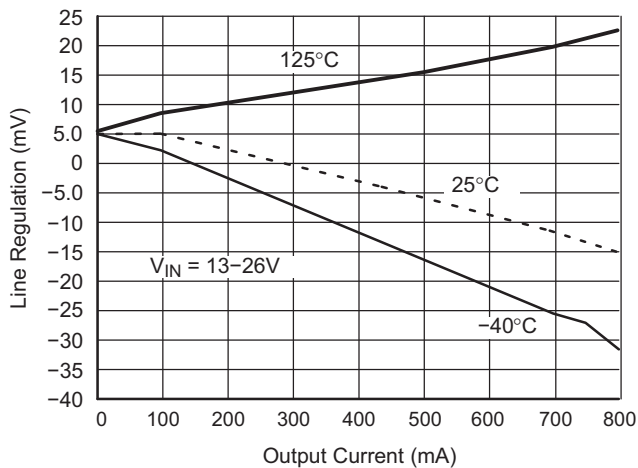

Figure 17. Line Regulation vs. Output Current for  $V_{OUT1}$

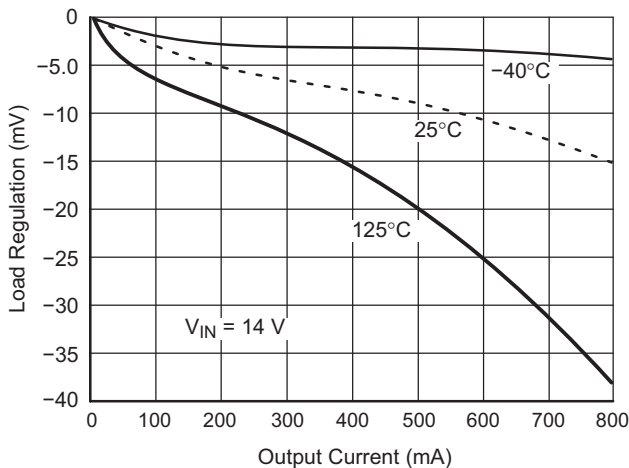

Figure 18. Load Regulation vs. Output Current for  $V_{OUT1}$

## DEFINITION OF TERMS

**Dropout Voltage** – The input–output voltage differential at which the circuit ceases to regulate against further reduction in input voltage. Measured when the output voltage has dropped 100 mV from the nominal value obtained at 14 V input, dropout voltage is dependent upon load current and junction temperature.

**Input Voltage** – The DC voltage applied to the input terminals with respect to ground.

**Input Output Differential** – The voltage difference between the unregulated input voltage and the regulated output voltage for which the regulator will operate.

**Line Regulation** – The change in output voltage for a change in the input voltage. The measurement is made under conditions of low dissipation or by using pulse techniques such that the average chip temperature is not significantly affected.

**Load Regulation** – The change in output voltage for a change in load current at constant chip temperature.

**Long Term Stability** – Output voltage stability under accelerated life–test conditions after 1000 hours with maximum rated voltage and junction temperature.

**Output Noise Voltage** – The rms AC voltage at the output, with constant load and no input ripple, measured over a specified frequency range.

**Quiescent Current** – The part of the positive input current that does not contribute to the positive load current, i.e., the regulator ground lead current.

**Ripple Rejection** – The ratio of the peak–to–peak input ripple voltage to the peak–to–peak output ripple voltage.

**Temperature Stability of  $V_{OUT}$**  – The percentage change in output voltage for a thermal variation from room temperature to either temperature extreme.

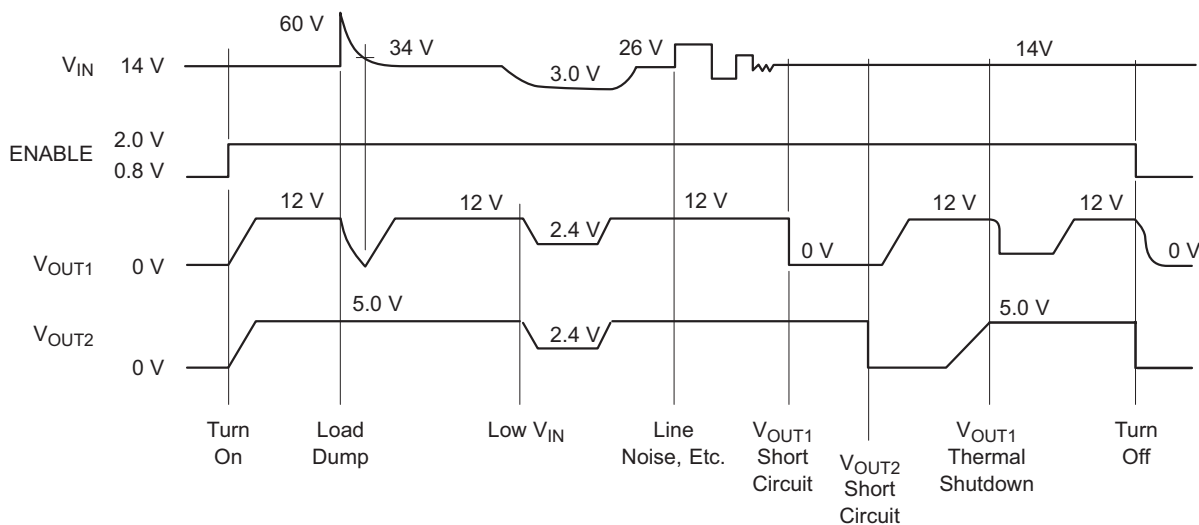

Figure 19. Typical Circuit Waveform

## APPLICATION NOTES

### Stability Considerations

The output or compensation capacitor helps determine three main characteristics of a linear regulator: start–up delay, load transient response and loop stability.

The capacitor value and type should be based on cost, availability, size and temperature constraints. A tantalum or aluminum electrolytic capacitor is best, since a film or ceramic capacitor with almost zero ESR can cause instability. The aluminum electrolytic capacitor is the cheapest solution, but, if the circuit operates at low temperatures ( $-25^{\circ}\text{C}$  to  $-40^{\circ}\text{C}$ ), both the value and ESR of the capacitor will vary considerably. The capacitor manufacturers data sheet usually provides this information.

The value for the output capacitors  $C_2$  and  $C_3$  shown in the test and applications circuit should work for most applications, however it is not necessarily the best solution.

To determine acceptable values for  $C_2$  and  $C_3$  for a particular application, start with a tantalum capacitor of the

recommended value and work towards a less expensive alternative part for each output.

**Step 1:** Place the completed circuit with a tantalum capacitor of the recommended value in an environmental chamber at the lowest specified operating temperature and monitor the outputs with an oscilloscope. A decade box connected in series with the capacitor  $C_2$  will simulate the higher ESR of an aluminum capacitor. Leave the decade box outside the chamber, the small resistance added by the longer leads is negligible.

**Step 2:** With the input voltage at its maximum value, increase the load current slowly from zero to full load while observing the output for any oscillations. If no oscillations are observed, the capacitor is large enough to ensure a stable design under steady state conditions.

**Step 3:** Increase the ESR of the capacitor from zero using the decade box and vary the load current until oscillations

appear. Record the values of load current and ESR that cause the greatest oscillation. This represents the worst case load conditions for the regulator at low temperature.

**Step 4:** Maintain the worst case load conditions set in step 3 and vary the input voltage until the oscillations increase. This point represents the worst case input voltage conditions.

**Step 5:** If the capacitor is adequate, repeat steps 3 and 4 with the next smaller valued capacitor. A smaller capacitor will usually cost less and occupy less board space. If the output oscillates within the range of expected operating conditions, repeat steps 3 and 4 with the next larger standard capacitor value.

**Step 6:** Test the load transient response by switching in various loads at several frequencies to simulate its real working environment. Vary the ESR to reduce ringing.

**Step 7:** Raise the temperature to the highest specified operating temperature. Vary the load current as instructed in step 5 to test for any oscillations.

Once the minimum capacitor value with the maximum ESR is found for each output, a safety factor should be added to allow for the tolerance of the capacitor and any variations in regulator performance. Most good quality aluminum electrolytic capacitors have a tolerance of  $\pm 20\%$  so the minimum value found should be increased by at least 50% to allow for this tolerance plus the variation which will occur at low temperatures. The ESR of the capacitors should be less than 50% of the maximum allowable ESR found in step 3 above.

Repeat steps 1 through 7 with  $C_3$ , the capacitor on the other output.

**Calculating Power Dissipation in a Dual Output Linear Regulator**

The maximum power dissipation for a dual output regulator (Figure 20) is

$$P_{D(max)} = (V_{IN(max)} - V_{OUT1(min)})I_{OUT1(max)} + (V_{IN(max)} - V_{OUT2(min)})I_{OUT2(max)} + V_{IN(max)}I_Q \quad (1)$$

where:

- $V_{IN(max)}$  is the maximum input voltage,
- $V_{OUT1(min)}$  is the minimum output voltage from  $V_{OUT1}$ ,
- $V_{OUT2(min)}$  is the minimum output voltage from  $V_{OUT2}$ ,
- $I_{OUT1(max)}$  is the maximum output current, for the application,
- $I_{OUT2(max)}$  is the maximum output current, for the application, and
- $I_Q$  is the quiescent current the regulator consumes at  $I_{OUT(max)}$ .

Once the value of  $P_{D(max)}$  is known, the maximum permissible value of  $R_{\theta JA}$  can be calculated:

$$R_{\theta JA} = \frac{150^{\circ}C - T_A}{P_D} \quad (2)$$

The value of  $R_{\theta JA}$  can be compared with those in the package section of the data sheet. Those packages with  $R_{\theta JA}$ 's less than the calculated value in equation 2 will keep the die temperature below  $150^{\circ}C$ .

In some cases, none of the packages will be sufficient to dissipate the heat generated by the IC, and an external heatsink will be required.

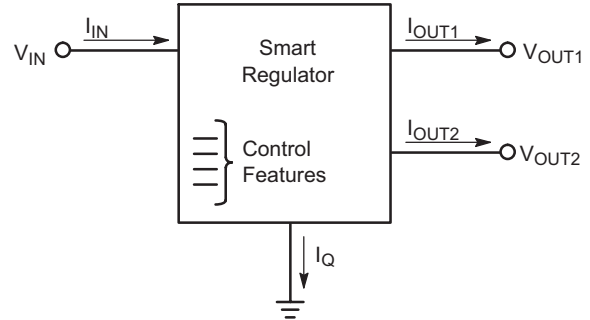

**Figure 20. Dual Output Regulator With Key Performance Parameters Labeled.**

**Heat Sinks**

A heat sink effectively increases the surface area of the package to improve the flow of heat away from the IC and into the surrounding air.

Each material in the heat flow path between the IC and the outside environment will have a thermal resistance. Like series electrical resistances, these resistances are summed to determine the value of  $R_{\theta JA}$ :

$$R_{\theta JA} = R_{\theta JC} + R_{\theta CS} + R_{\theta SA} \quad (3)$$

where:

- $R_{\theta JC}$  = the junction-to-case thermal resistance,
- $R_{\theta CS}$  = the case-to-heatsink thermal resistance, and
- $R_{\theta SA}$  = the heatsink-to-ambient thermal resistance.

$R_{\theta JC}$  appears in the package section of the data sheet. Like  $R_{\theta JA}$ , it too is a function of package type.  $R_{\theta CS}$  and  $R_{\theta SA}$  are functions of the package type, heatsink and the interface between them. These values appear in heat sink data sheets of heat sink manufacturers.

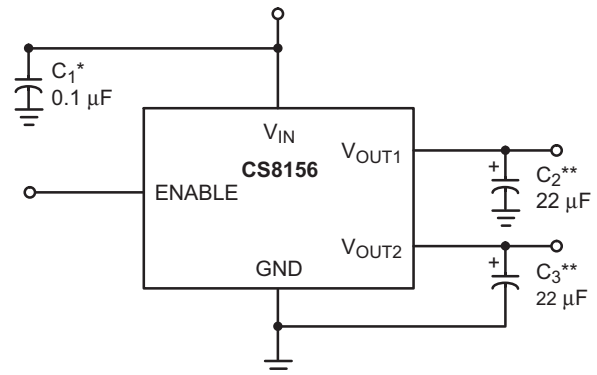

\*  $C_1$  is required if the regulator is far from power supply filter.  
 \*\*  $C_2, C_3$  required for stability.

**Figure 21. Test & Application Circuit**



# CS8156

## ORDERING INFORMATION

Device	Package	Shipping†
CS8156YT5	TO-220 FIVE LEAD STRAIGHT	50 Units/Rail
CS8156YT5G	TO-220 FIVE LEAD STRAIGHT (Pb-Free)	50 Units/Rail
CS8156YTVA5	TO-220 FIVE LEAD VERTICAL	50 Units/Rail
CS8156YTVA5G	TO-220 FIVE LEAD VERTICAL (Pb-Free)	50 Units/Rail
CS8156YTHA5	TO-220 FIVE LEAD HORIZONTAL	50 Units/Rail
CS8156YTHA5G	TO-220 FIVE LEAD HORIZONTAL (Pb-Free)	50 Units/Rail

†For information on tape and reel specifications, including part orientation and tape sizes, please refer to our Tape and Reel Packaging Specifications Brochure, BRD8011/D.

# CS8156

## PACKAGE DIMENSIONS

TO-220  
FIVE LEAD  
T SUFFIX  
CASE 314D-04  
ISSUE E

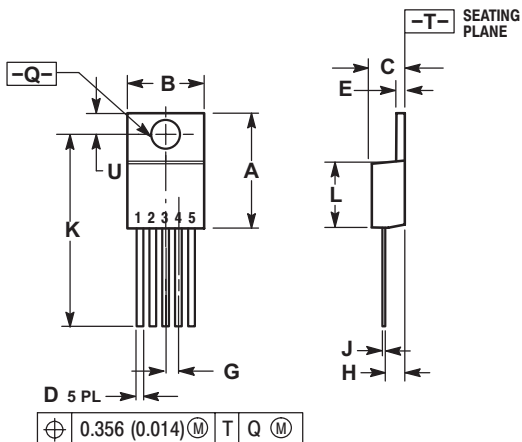

- NOTES:
1. DIMENSIONING AND TOLERANCING PER ANSI Y14.5M, 1982.
  2. CONTROLLING DIMENSION: INCH.
  3. DIMENSION D DOES NOT INCLUDE INTERCONNECT BAR (DAMBAR) PROTRUSION. DIMENSION D INCLUDING PROTRUSION SHALL NOT EXCEED 10.92 (0.043) MAXIMUM.

DIM	INCHES		MILLIMETERS	
	MIN	MAX	MIN	MAX
A	0.572	0.613	14.529	15.570
B	0.390	0.415	9.906	10.541
C	0.170	0.180	4.318	4.572
D	0.025	0.038	0.635	0.965
E	0.048	0.055	1.219	1.397
G	0.067 BSC		1.702 BSC	
H	0.087	0.112	2.210	2.845
J	0.015	0.025	0.381	0.635
K	0.990	1.045	25.146	26.543
L	0.320	0.365	8.128	9.271
Q	0.140	0.153	3.556	3.886
U	0.105	0.117	2.667	2.972

TO-220  
FIVE LEAD  
TVA SUFFIX  
CASE 314K-01  
ISSUE O

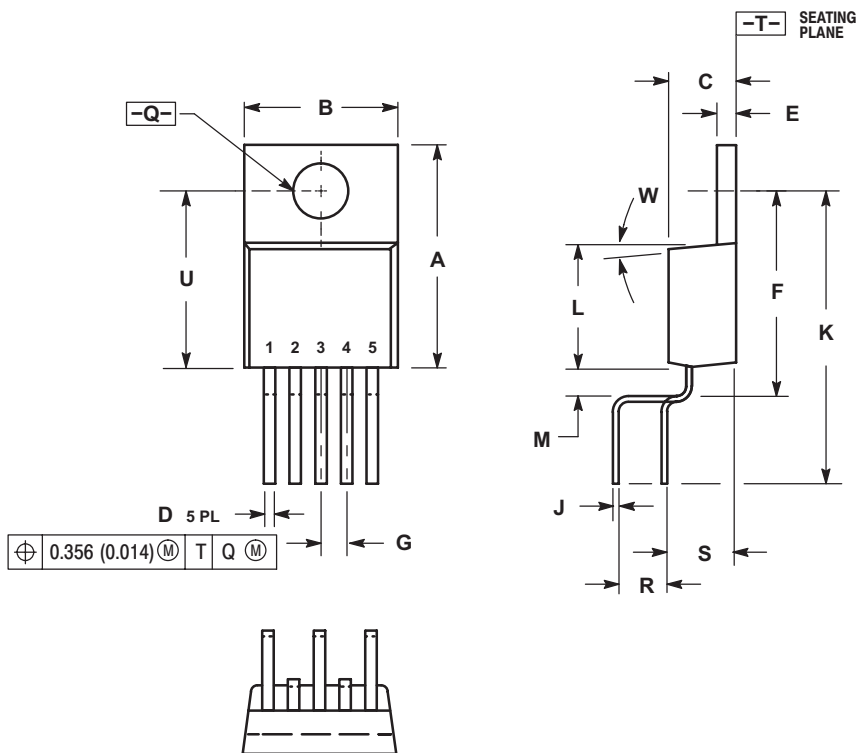

- NOTES:
1. DIMENSIONING AND TOLERANCING PER ANSI Y14.5M, 1982.
  2. CONTROLLING DIMENSION: INCH.
  3. DIMENSION D DOES NOT INCLUDE INTERCONNECT BAR (DAMBAR) PROTRUSION. DIMENSION D INCLUDING PROTRUSION SHALL NOT EXCEED 10.92 (0.043) MAXIMUM.

DIM	INCHES		MILLIMETERS	
	MIN	MAX	MIN	MAX
A	0.560	0.590	14.22	14.99
B	0.385	0.415	9.78	10.54
C	0.160	0.190	4.06	4.83
D	0.027	0.037	0.69	0.94
E	0.045	0.055	1.14	1.40
F	0.530	0.545	13.46	13.84
G	0.067 BSC		1.70 BSC	
J	0.014	0.022	0.36	0.56
K	0.785	0.800	19.94	20.32
L	0.321	0.337	8.15	8.56
M	0.063	0.078	1.60	1.98
Q	0.146	0.156	3.71	3.96
R	0.271	0.321	6.88	8.15
S	0.146	0.196	3.71	4.98
U	0.460	0.475	11.68	12.07
W	5°		5°	

# CS8156

## TO-220 FIVE LEAD THA SUFFIX CASE 314A-03 ISSUE E

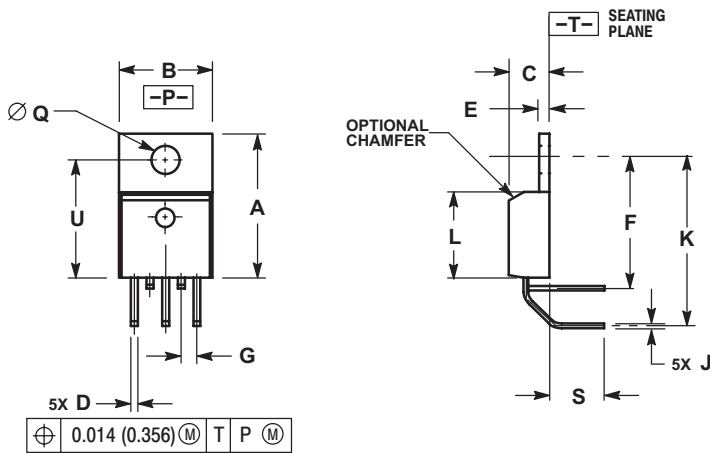

### NOTES:

1. DIMENSIONING AND TOLERANCING PER ANSI Y14.5M, 1982.
2. CONTROLLING DIMENSION: INCH.
3. DIMENSION D DOES NOT INCLUDE INTERCONNECT BAR (DAMBAR) PROTRUSION. DIMENSION D INCLUDING PROTRUSION SHALL NOT EXCEED 0.043 (1.092) MAXIMUM.

DIM	INCHES		MILLIMETERS	
	MIN	MAX	MIN	MAX
A	0.572	0.613	14.529	15.570
B	0.390	0.415	9.906	10.541
C	0.170	0.180	4.318	4.572
D	0.025	0.038	0.635	0.965
E	0.048	0.055	1.219	1.397
F	0.570	0.585	14.478	14.859
G	0.067 BSC		1.702 BSC	
J	0.015	0.025	0.381	0.635
K	0.730	0.745	18.542	18.923
L	0.320	0.365	8.128	9.271
Q	0.140	0.153	3.556	3.886
S	0.210	0.260	5.334	6.604
U	0.468	0.505	11.888	12.827

### PACKAGE THERMAL DATA

Parameter		TO-220 FIVE LEAD	Unit
$R_{\theta JC}$	Typical	2.0	$^{\circ}\text{C}/\text{W}$
$R_{\theta JA}$	Typical	50	$^{\circ}\text{C}/\text{W}$

ON Semiconductor and are registered trademarks of Semiconductor Components Industries, LLC (SCILLC). SCILLC reserves the right to make changes without further notice to any products herein. SCILLC makes no warranty, representation or guarantee regarding the suitability of its products for any particular purpose, nor does SCILLC assume any liability arising out of the application or use of any product or circuit, and specifically disclaims any and all liability, including without limitation special, consequential or incidental damages. "Typical" parameters which may be provided in SCILLC data sheets and/or specifications can and do vary in different applications and actual performance may vary over time. All operating parameters, including "Typicals" must be validated for each customer application by customer's technical experts. SCILLC does not convey any license under its patent rights nor the rights of others. SCILLC products are not designed, intended, or authorized for use as components in systems intended for surgical implant into the body, or other applications intended to support or sustain life, or for any other application in which the failure of the SCILLC product could create a situation where personal injury or death may occur. Should Buyer purchase or use SCILLC products for any such unintended or unauthorized application, Buyer shall indemnify and hold SCILLC and its officers, employees, subsidiaries, affiliates, and distributors harmless against all claims, costs, damages, and expenses, and reasonable attorney fees arising out of, directly or indirectly, any claim of personal injury or death associated with such unintended or unauthorized use, even if such claim alleges that SCILLC was negligent regarding the design or manufacture of the part. SCILLC is an Equal Opportunity/Affirmative Action Employer. This literature is subject to all applicable copyright laws and is not for resale in any manner.

### PUBLICATION ORDERING INFORMATION

**LITERATURE FULFILLMENT:**  
Literature Distribution Center for ON Semiconductor  
P.O. Box 61312, Phoenix, Arizona 85082-1312 USA  
**Phone:** 480-829-7710 or 800-344-3860 Toll Free USA/Canada  
**Fax:** 480-829-7709 or 800-344-3867 Toll Free USA/Canada  
**Email:** orderlit@onsemi.com

**N. American Technical Support:** 800-282-9855 Toll Free  
USA/Canada

**Japan:** ON Semiconductor, Japan Customer Focus Center  
2-9-1 Kamimeguro, Meguro-ku, Tokyo, Japan 153-0051  
**Phone:** 81-3-5773-3850

**ON Semiconductor Website:** <http://onsemi.com>

**Order Literature:** <http://www.onsemi.com/litorder>

For additional information, please contact your local Sales Representative.