

Evaluation Board for the ADP2119/ADP2120 Step-Down Regulator

GENERAL DESCRIPTION

The [ADP2119/ADP2120](#) are synchronous, step-down, dc-to-dc regulators in a compact 3 mm × 3 mm LFCSP_WD package.

The ADP2119/ADP2120 evaluation boards provide an easy way to evaluate the device. This user guide describes how to quickly set up the board to collect performance data. Full details on the ADP2119/ADP2120 are available in the ADP2119/ADP2120 data sheet, which is available from Analog Devices, Inc., and

should be consulted in conjunction with this user guide when using the evaluation boards.

The ADP2119/ADP2120 run from input voltages of 2.3 V to 5.5 V and require minimal external components to provide a high efficiency solution with integrated power switch, synchronous rectifier, and internal compensation.

ADP2119/ADP2120 EVALUATION BOARDS

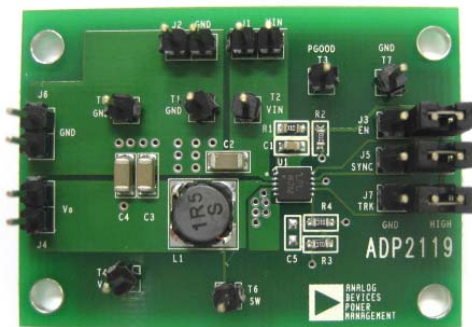

09314-001

Figure 1. ADP2119 Evaluation Board

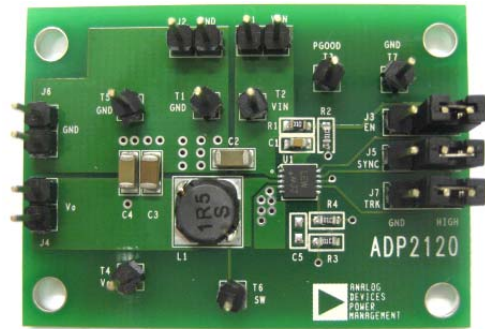

09314-002

Figure 2. ADP2120 Evaluation Board

TABLE OF CONTENTS

General Description	1	Typical Performance Characteristics	5
ADP2119/ADP2120 Evaluation Boards	1	Evaluation Board Schematics and Artwork	6
Revision History	2	Evaluation Board Layout	7
Setting Up the Evaluation Board	3	Ordering Information	8
Powering up the Evaluation Board	3	Bill of Materials.....	8
Measuring Evaluation Board Performance.....	3		

REVISION HISTORY

9/10—Revision 0: Initial Version

SETTING UP THE EVALUATION BOARD

POWERING UP THE EVALUATION BOARD

The ADP2119/ADP2120 evaluation boards are fully assembled and tested. Before applying power to the evaluation boards, follow the setup procedures in this section.

Jumper Settings

Refer to Table 1 for selecting the jumper positions.

Before selecting the jumper positions, make sure that the enable input, EN, is high.

Table 1. Jumper Settings

Jumper	States	Function
J3 (EN)	High	Enable V_{OUT}
	Low	Disable V_{OUT}
J5 (SYNC/MODE)	High	Force PWM (FPWM)
	Low	Enable PFM
	External clock	Synchronize to the external clock
J7 (TRK)	High	Tracking function not used
	External voltage	Tracking with the external voltage

Input Power Source Connection

Before connecting the power source to the ADP2119/ADP2120 evaluation boards, make sure that they are turned off. If the input power source includes a current meter, use that meter to monitor the input current.

Connect the positive terminal of the power source to the VIN terminal (J1) on the evaluation boards, and the negative terminal of the power source to the GND terminal (J2) of the board. If the power source does not include a current meter, connect a current meter in series with the input source voltage.

Connect the positive terminal of the power source to the ammeter positive terminal (+), the negative terminal of the power source to the GND terminal (J2) on the evaluation board, and the negative terminal (–) of the ammeter to the VIN terminal (J1) on the board.

Output Load Connection

Make sure that the board is turned off before connecting the load. If the load includes an ammeter, or if the current is not measured, connect the load directly to the evaluation board with the positive (+) load connection to the VOUT terminal (J4) and negative (–) load connection to the GND terminal (J6).

If an ammeter is used, connect it in series with the load; connect the positive (+) ammeter terminal to the evaluation board VOUT terminal (J4), the negative (–) ammeter terminal to the positive (+) load terminal, and the negative (–) load terminal to the evaluation board GND terminal (J6).

Input and Output Voltmeter Connections

Measure the input and output voltages with voltmeters. Make sure that the voltmeters are connected to the appropriate test

points on the board. If the voltmeters are not connected to the right test point, the measured voltages may be incorrect due to the voltage drop across the leads and/or connections between the boards, the power source, and/or load.

Connect the positive (+) terminal of the input voltage measuring voltmeter to Test Point T2 and the negative (–) terminal to Test Point T1.

Connect the positive (+) terminal of the output voltage measuring voltmeter to Test Point T4 and the negative (–) terminal to Test Point T5.

Power On the Evaluation Board

When the power source and load are connected to the ADP2119/ADP2120 evaluation board, it can be powered up for operation. If the input power source is above 2.3 V, the output voltage rises to 1.2 V as the default setting.

MEASURING EVALUATION BOARD PERFORMANCE

Measuring the Switching Waveform

To observe the switching waveform with an oscilloscope, place the oscilloscope probe tip at Test Point T6 with the probe ground connected to GND. Set the oscilloscope to a dc coupling, 2 V/division, and 1 μ s/division time base. The switching waveform should alternate between 0 V and approximately the input voltage.

Measuring Load Regulation

Load regulation should be tested by increasing the load at the output and measuring the output voltage between the T4 and T5 test points.

Measuring Line Regulation

Vary the input voltage and measure the output voltage at a fixed output current. Input voltage can be measured between T2 and T1. The output voltage is measured between T4 and T5.

Measuring Efficiency

The efficiency, η , is measured by comparing the input power with the output power.

$$\eta = \frac{V_{OUT} \times I_{OUT}}{V_{IN} \times I_{IN}}$$

Measuring Inductor Current

The inductor current can be measured by removing one end of the inductor from the pad on the board and using a wire connected between the pad and the inductor. Then, a current probe can be used to measure the inductor current.

Measuring Output Voltage Ripple

To observe the output voltage ripple, place an oscilloscope probe across the output capacitor (C4) with the probe ground lead placed at the negative (–) capacitor terminal and the probe tip placed at the positive (+) capacitor terminal. Set the oscillo-

scope to an ac coupling, 10 mV/division, 2 μ s/division time base and 20 MHz bandwidth.

A standard oscilloscope probe has a long wire ground clip. For high frequency measurements, this ground clip picks up high frequency noise and injects it into the measured output ripple. Figure 3 shows an easy way to measure the output ripple properly. It requires removing the oscilloscope probe sheath and wrapping a nonshielded wire around the oscilloscope probe. By keeping the ground lengths of the oscilloscope probe as short as possible, true ripple can be measured.

Output Voltage Change

The ADP2119/ADP2120 evaluation board output is preset to 1.2 V; however, the output voltage can be adjusted using the following equation:

$$V_{OUT} = 0.6 \text{ V} \times \left(\frac{R4 + R3}{R4} \right)$$

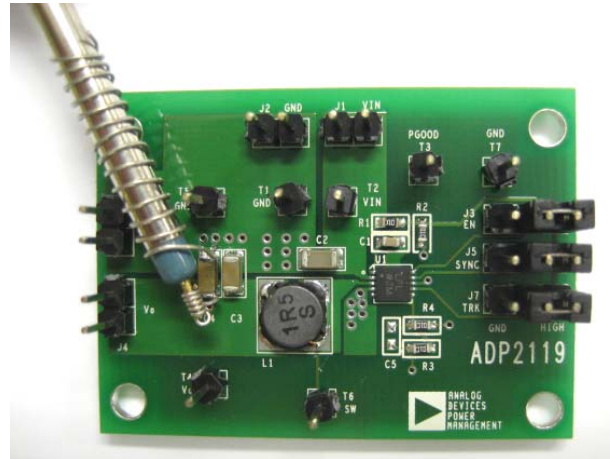

Figure 3. Output Ripple Measurement

08314-003

TYPICAL PERFORMANCE CHARACTERISTICS

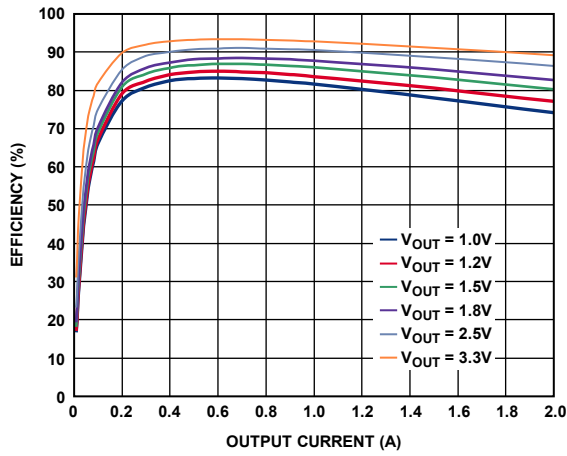

Figure 4. ADP2119 Efficiency, $V_{IN} = 5V$, FPWM

09314-004

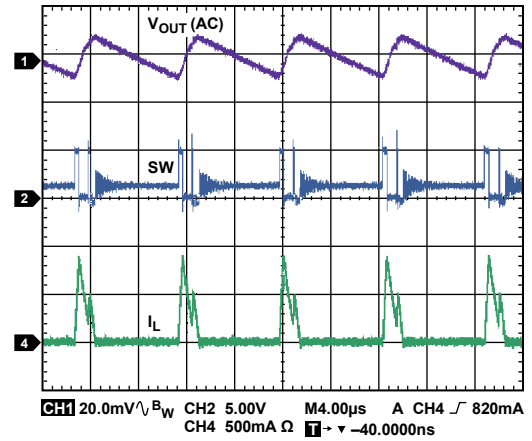

Figure 7. PFM Mode (ADP2120)

09314-007

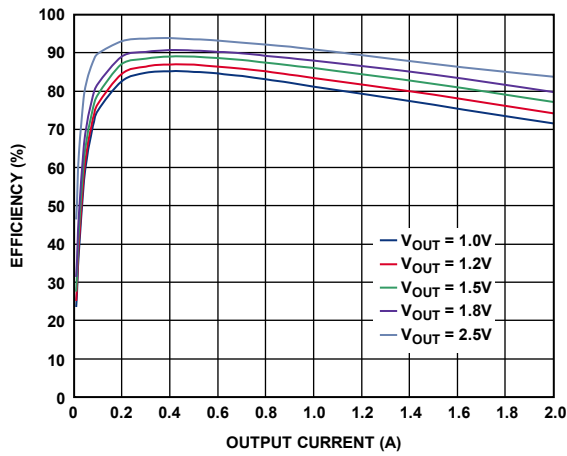

Figure 5. ADP2119 Efficiency, $V_{IN} = 3.3V$, FPWM

09314-005

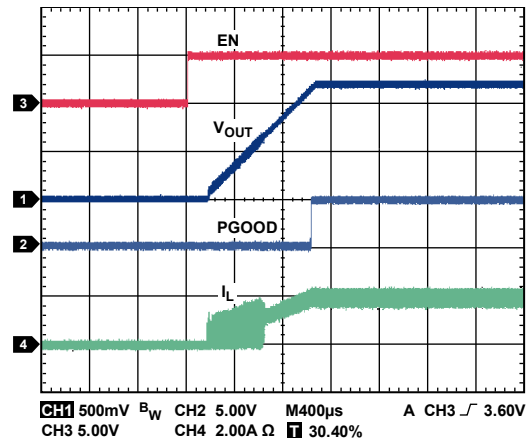

Figure 8. Soft Start (ADP2119, $V_{IN} = 5V$, $V_{OUT} = 1.2V$)

09314-008

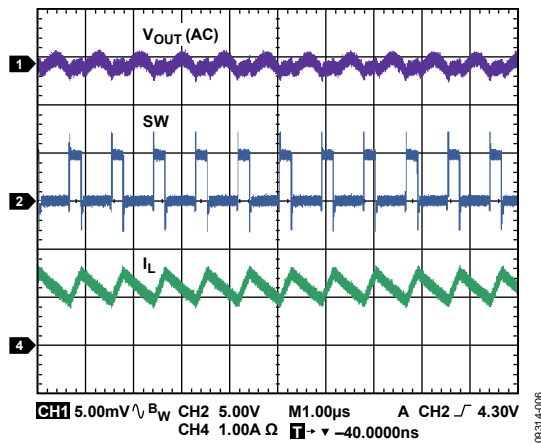

Figure 6. Continuous Conduction Mode (ADP2120)

09314-006

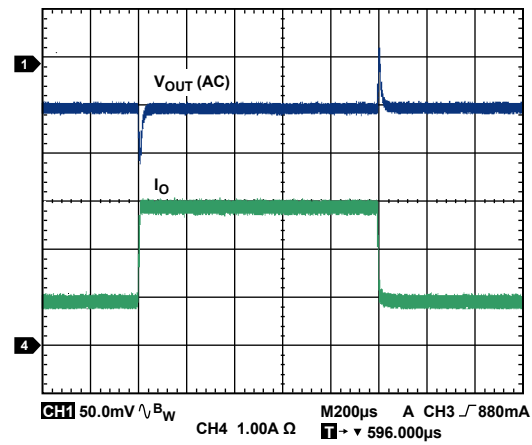

Figure 9. Load Transient (ADP2119, FPWM, $V_{IN} = 5V$, $V_{OUT} = 1.2V$)

09314-009

EVALUATION BOARD SCHEMATICS AND ARTWORK

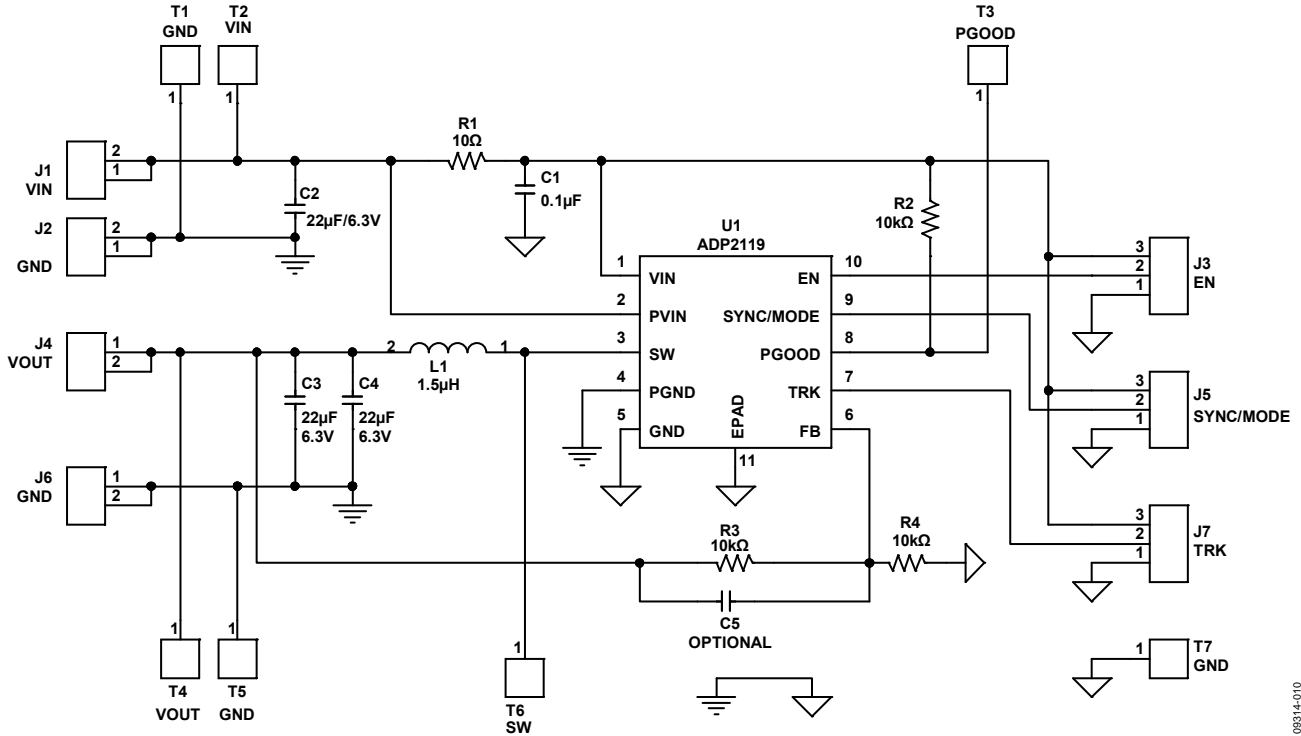

Figure 10. ADP2119 Evaluation Board Schematic

08314-010

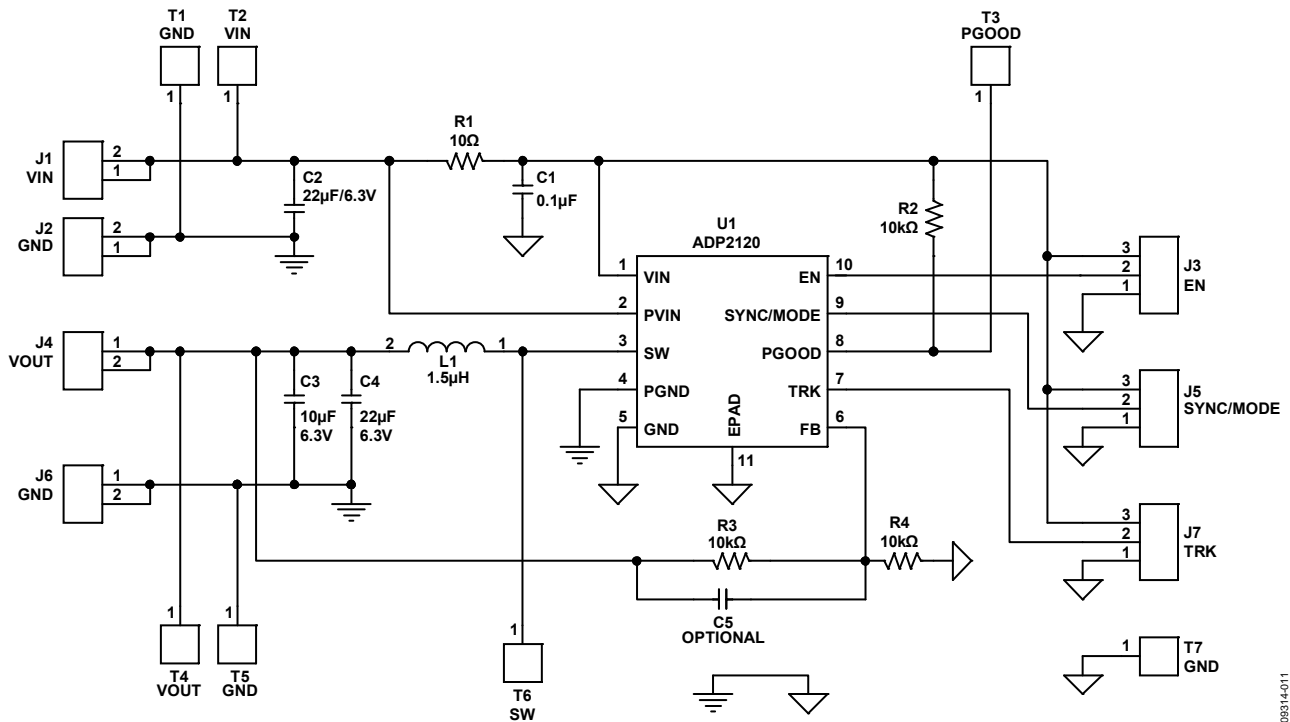

Figure 11. ADP2120 Evaluation Board Schematic

08314-011

EVALUATION BOARD LAYOUT

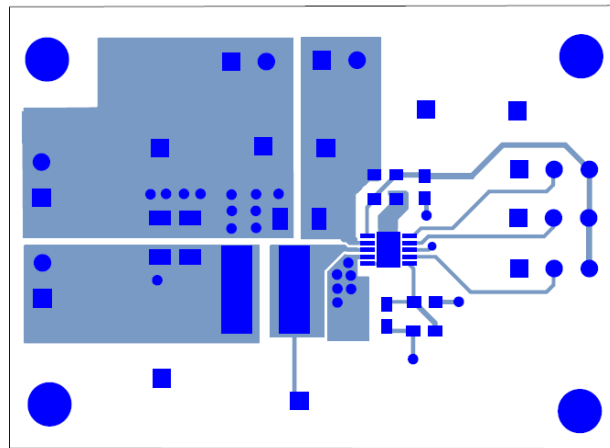

Figure 12. Top Layer

08314-012

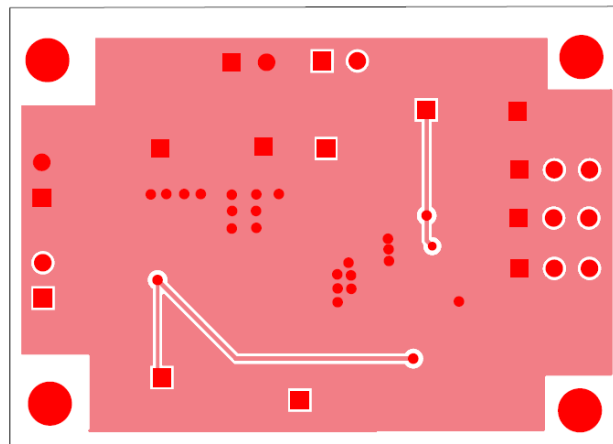

Figure 13. Bottom Layer

08314-014

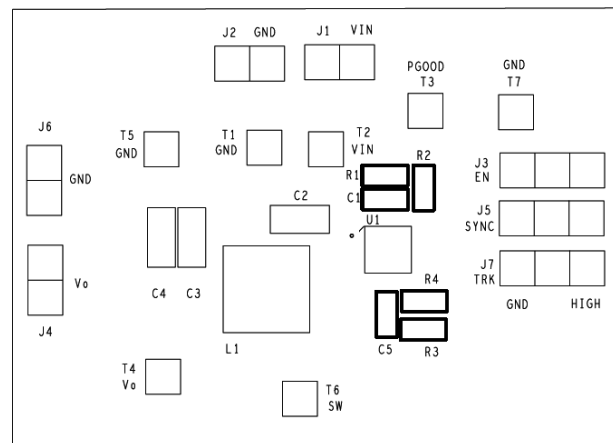

Figure 14. Silkscreen Top

08314-013

ORDERING INFORMATION

BILL OF MATERIALS

Table 2. ADP2119 Evaluation Board Bill of Materials

Qty	Part Reference	Type	Description	PCB Footprint	Vendor	Part Number
1	C1	Capacitor	0.1 μ F, 50 V	C0603	Murata	GRM188F51H104ZA01
3	C2, C3, C4	Capacitor	22 μ F, 6.3 V, X5R	C1206	Murata	GRM31CR60J226KE19
1	C5	Capacitor	Optional	C0603	Murata	Optional
1	L1	Inductor	1.5 μ H	Sumida_CDRH5D18	Sumida	CDRH5D18BHPNP-1R5M
1	R1	Resistor	10 Ω	R0603	Vishay Dale	CRCW060310R0FKEA
3	R2, R3, R4	Resistor	10 k Ω , 1%	R0603	Vishay Dale	CRCW060310K0JKTA
1	U1	IC	2 A buck regulator	10-lead LFCSP_WD	Analog Devices	ADP2119ACPZ-R7
7	T1,T2, T3, T4, T5, T6, T7	Test point	SIP1	SIP1	Harwin	M20-9990245
4	J1, J2, J4, J6	Connector	SIP2	SIP2	Harwin	M20-9990245
3	J3, J5, J7	Jumper	SIP3	SIP3	Harwin	M20-9990346

Table 3. ADP2120 Evaluation Board Bill of Materials

Qty	Part Reference	Type	Description	PCB Footprint	Vendor	Part Number
1	C1	Capacitor	0.1 μ F, 50 V	C0603	Murata	GRM188F51H104ZA01
2	C2, C4	Capacitor	22 μ F, 6.3 V, X5R	C1206	Murata	GRM31CR60J226KE19
1	C3	Capacitor	10 μ F, 6.3 V, X5R	C1206	Murata	GRM319R60J106KE19
1	C5	Capacitor	Optional	C0603	Murata	Optional
1	L1	Inductor	1.5 μ H	Sumida_CDRH5D18	Sumida	CDRH5D18BHPNP-1R5M
1	R1	Resistor	10 Ω	R0603	Vishay Dale	CRCW060310R0FKEA
3	R2, R3, R4	Resistor	10 k Ω , 1%	R0603	Vishay Dale	CRCW060310K0JKTA
1	U1	IC	1.25 A buck regulator	10-lead LFCSP_WD	Analog Devices	ADP2120ACPZ-R7
7	T1,T2, T3, T4, T5, T6, T7	Test point	SIP1	SIP1	Harwin	M20-9990245
4	J1, J2, J4, J6	Connector	SIP2	SIP2	Harwin	M20-9990245
3	J3, J5, J7	Jumper	SIP3	SIP3	Harwin	M20-9990346



ESD Caution

ESD (electrostatic discharge) sensitive device. Charged devices and circuit boards can discharge without detection. Although this product features patented or proprietary protection circuitry, damage may occur on devices subjected to high energy ESD. Therefore, proper ESD precautions should be taken to avoid performance degradation or loss of functionality.

Legal Terms and Conditions

By using the evaluation board discussed herein (together with any tools, components documentation or support materials, the "Evaluation Board"), you are agreeing to be bound by the terms and conditions set forth below ("Agreement") unless you have purchased the Evaluation Board, in which case the Analog Devices Standard Terms and Conditions of Sale shall govern. Do not use the Evaluation Board until you have read and agreed to the Agreement. Your use of the Evaluation Board shall signify your acceptance of the Agreement. This Agreement is made by and between you ("Customer") and Analog Devices, Inc. ("ADI"), with its principal place of business at One Technology Way, Norwood, MA 02062, USA. Subject to the terms and conditions of the Agreement, ADI hereby grants to Customer a free, limited, personal, temporary, non-exclusive, non-sublicensable, non-transferable license to use the Evaluation Board FOR EVALUATION PURPOSES ONLY. Customer understands and agrees that the Evaluation Board is provided for the sole and exclusive purpose referenced above, and agrees not to use the Evaluation Board for any other purpose. Furthermore, the license granted is expressly made subject to the following additional limitations: Customer shall not (i) rent, lease, display, sell, transfer, assign, sublicense, or distribute the Evaluation Board; and (ii) permit any Third Party to access the Evaluation Board. As used herein, the term "Third Party" includes any entity other than ADI, Customer, their employees, affiliates and in-house consultants. The Evaluation Board is NOT sold to Customer; all rights not expressly granted herein, including ownership of the Evaluation Board, are reserved by ADI. CONFIDENTIALITY. This Agreement and the Evaluation Board shall all be considered the confidential and proprietary information of ADI. Customer may not disclose or transfer any portion of the Evaluation Board to any other party for any reason. Upon discontinuation of use of the Evaluation Board or termination of this Agreement, Customer agrees to promptly return the Evaluation Board to ADI. ADDITIONAL RESTRICTIONS. Customer may not disassemble, decompile or reverse engineer chips on the Evaluation Board. Customer shall inform ADI of any occurred damages or any modifications or alterations it makes to the Evaluation Board, including but not limited to soldering or any other activity that affects the material content of the Evaluation Board. Modifications to the Evaluation Board must comply with applicable law, including but not limited to the RoHS Directive. TERMINATION. ADI may terminate this Agreement at any time upon giving written notice to Customer. Customer agrees to return to ADI the Evaluation Board at that time. LIMITATION OF LIABILITY. THE EVALUATION BOARD PROVIDED HEREUNDER IS PROVIDED "AS IS" AND ADI MAKES NO WARRANTIES OR REPRESENTATIONS OF ANY KIND WITH RESPECT TO IT. ADI SPECIFICALLY DISCLAIMS ANY REPRESENTATIONS, ENDORSEMENTS, GUARANTEES, OR WARRANTIES, EXPRESS OR IMPLIED, RELATED TO THE EVALUATION BOARD INCLUDING, BUT NOT LIMITED TO, THE IMPLIED WARRANTY OF MERCHANTABILITY, TITLE, FITNESS FOR A PARTICULAR PURPOSE OR NON-INFRINGEMENT OF INTELLECTUAL PROPERTY RIGHTS. IN NO EVENT WILL ADI AND ITS LICENSORS BE LIABLE FOR ANY INCIDENTAL, SPECIAL, INDIRECT, OR CONSEQUENTIAL DAMAGES RESULTING FROM CUSTOMER'S POSSESSION OR USE OF THE EVALUATION BOARD, INCLUDING BUT NOT LIMITED TO LOST PROFITS, DELAY COSTS, LABOR COSTS OR LOSS OF GOODWILL. ADI'S TOTAL LIABILITY FROM ANY AND ALL CAUSES SHALL BE LIMITED TO THE AMOUNT OF ONE HUNDRED US DOLLARS (\$100.00). EXPORT. Customer agrees that it will not directly or indirectly export the Evaluation Board to another country, and that it will comply with all applicable United States federal laws and regulations relating to exports. GOVERNING LAW. This Agreement shall be governed by and construed in accordance with the substantive laws of the Commonwealth of Massachusetts (excluding conflict of law rules). Any legal action regarding this Agreement will be heard in the state or federal courts having jurisdiction in Suffolk County, Massachusetts, and Customer hereby submits to the personal jurisdiction and venue of such courts. The United Nations Convention on Contracts for the International Sale of Goods shall not apply to this Agreement and is expressly disclaimed.