



## H38 | ABSOLUTE EXPLOSION-PROOF ENCODER

### Introduction

The H38 absolute is an explosion proof version of the field-proven H25 encoder series. The H38 is UL certified for NEMA Class 4X and 6 (outdoor non-hazardous locations) and Class 4X and 13 (indoor non-hazardous locations). It is available with single and triple certifications for use in hazardous locations and includes a standard shaft seal, double bearing seals, and a cast aluminum housing with hard anodized and dichromate sealed finish. The H38 absolute encoder is suitable for use in petroleum service industries, solvent refining operations, spray painting applications, and explosive dust environments. When your application needs the ability to recover position information quickly after a power loss and you are operating in a hazardous area—the H38 may be the answer to your needs.



### Features

- Parallel 12 / 13 bit or SSI Transmission
- Transmission lengths to 1000 feet
- Accepts clock rates from 100 KHz to 1.8 MHz



### SPECIFICATIONS

#### Electrical

<b>Code</b>	12 or 13 bits NB or GC; excess gray and BCD available
<b>Counts Per Shaft Turn</b>	4096 or 8192
<b>Count Transition Accuracy</b>	± 1/2 bit maximum
<b>Supply Voltage</b>	5–28 VDC
<b>Current Requirements</b>	120 mA typical
<b>Output Formats</b>	Parallel: Gray Code, Natural Binary and Binary Coded Decimal; Serial: Serial Synchronous Interface (SSI); Analog: 4–20 mA, 0–10V
<b>Voltage/Output</b>	<b>28V/V:</b> Line Driver, 5–28 VDC in, Vout = Vin <b>28V/5:</b> Line Driver, 5–28 VDC in, Vout = 5 VDC <b>28V/OC:</b> Open Collector, 5–28 VDC in OCout <b>SSI:</b> 5–28 VDC in/5Vout
<b>Protection Level</b>	Reverse, overvoltage and output short circuit protection
<b>Frequency Response</b>	100kHz (1200 RPM for 12-bits, 600 RPM for 13-bits)
<b>Output Termination Pinouts</b>	See Table 1 or Table 2



## Mechanical

<b>Shaft Diameter</b>	3/8" nominal
<b>Flats On Shaft</b>	Two flats, 0.80" long X 0.30" deep at 90°
<b>Shaft Loading</b>	Up to 40 pounds axial and 20 pounds radial applied 1/4" from housing
<b>Shaft Runout</b>	0.0005 T.I.R
<b>Starting Torque at 25°C</b>	4.0 in-oz (max)
<b>Bearings</b>	Class ABEC 7 standard
<b>Shaft Material</b>	303 stainless steel
<b>Enclosure</b>	Die cast aluminum, hard anodized with dichromate sealed finish. Shaft seals and sealed bearings are standard to achieve environmental ratings.
<b>Bearing Life</b>	2 X 10 <sup>8</sup> revs (1300 hrs at 2500 RPM) at rated load; 1 X 10 <sup>10</sup> revs (67,000 hrs at 2500 RPM) at 10% of rated load
<b>Maximum RPM</b>	10,000 RPM (see frequency response, below)
<b>Moment of Inertia</b>	4.1 X 10 <sup>-4</sup> oz-in-sec <sup>2</sup>
<b>Weight</b>	64 oz typical (approx 4 lbs)

## Environmental

<b>Enclosure Rating</b>	NEMA 4 X & 6 (IP66), outdoor Non-Hazardous locations, NEMA 4 X & 13 (IP66), indoor Non-Hazardous locations
<b>Temperature</b>	Standard operating all models, 0° to +70°C; Storage all models, -50° to +90°C; Extended temp testing avail.: for UL, -40° to +80°C; for CEN, -50° to +90°C
<b>Shock</b>	50 g's at 11 msec
<b>Vibration</b>	5 to 2000 Hz @ 20 g's
<b>Humidity</b>	100% RH
<b>Hazardous Area Rating</b>	Underwriters Laboratories listed for use in hazardous locations; NEMA Enclosure 7. Class I, Div. 1, Group D or Class I, Div. 1, Groups C, D and CLASS II, Div. 1, Groups E, F, G.

**Notes & Tables:** All notes and tables referred to in the text can be found on the back of this page.



# DIMENSIONS

Dimensions in inches

### H38 WITH UL MODEL OPTION

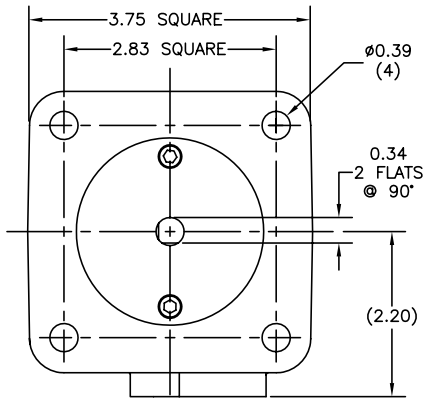

### H38 WITH CEN MODEL OPTION

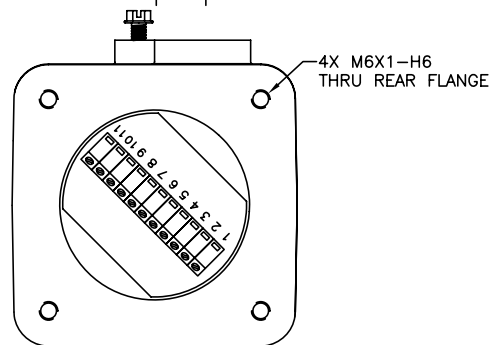
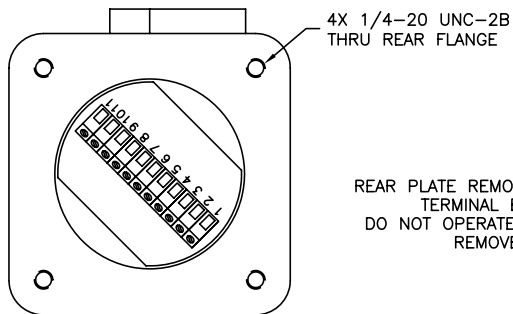
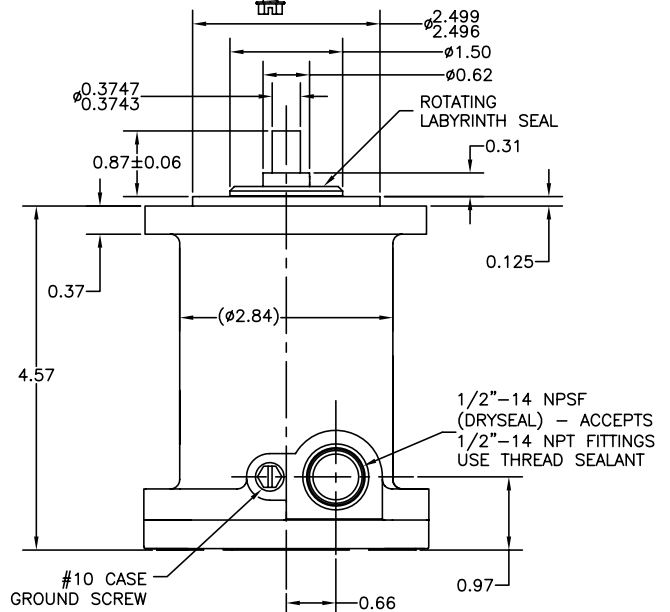
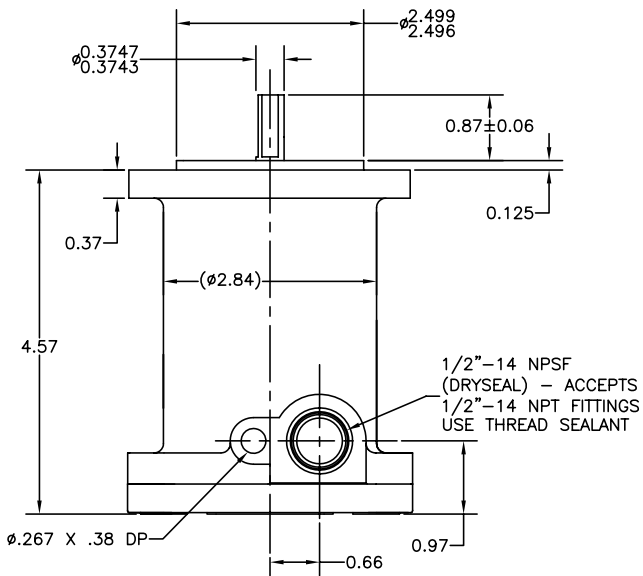
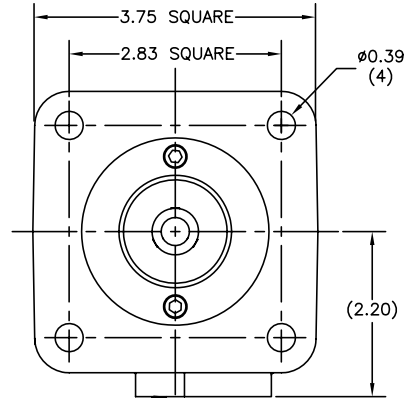

REAR PLATE REMOVED TO SHOW TERMINAL BOARD.  
DO NOT OPERATE WITH PLATE REMOVED.



### Serial Synchronous Interface (SSI)

SSI output provides effective synchronization in a closed-loop control system. A clock pulse train from a controller is used to clock out sensor data: one bit of position data is transmitted to the controller per one clock pulse received by the sensor. The use of a differential driver permits reliable transmission of data over long distances in environments that may be electrically noisy. The encoder utilizes a clock signal, provided by the user interface, to time the data transmission. Receiving electronics must include an appropriate receiver as well as line terminating resistors.

### Data Transmission Sequence

1. Output driver of the encoder is a MAX 491 transceiver in transmit mode. The recommended receiver is a MAX 491 transceiver in receive mode.
2. Controller provides a series of pulses (or differential pulse pairs) on the CLOCK input lines.
3. On the first HIGH-to-LOW CLOCK transition, the encoder latches its data at the current position and prepares to transmit.
4. Controller reads data on the falling edge of the next 15 clock cycles.
5. The first bit is a START bit and is always HIGH.
6. Next comes 13 data bits beginning with the most significant bit (MSB) and ending with the parity bit. On 12 bit encoders, bit 13 is LOW. When parity is not ordered, parity is LOW.
7. After the last CLOCK HIGH-to-LOW transition, a minimum of 40 microseconds must pass before the beginning of the next CLOCK series.

### Interfacing Long Data Lines

**Ordering SSI:** HOW TO SPECIFY SSI OUTPUT IN THE ENCODER MODEL NUMBER: Use the designation, S3 between the Code Format designation and the Connector designation. Example: H38D-12GC-S3-CW-SC-CEN

Cable impedance can create a transmission delay, in effect, shifting the phase relationship between the clock pulse and the data. If this phase shift exceeds 180°, then the wrong bit position will be sampled by the receiver. As a result, the maximum allowable clock frequency is a function of the cable length. For 24 AWG, stranded, 3 pair cable (BEI part number 37048-003 or equivalent) the group delay is 1.36ns/ft. The table below shows the maximum transmission rate allowable as a function of cable length to ensure a phase shift of less than 90°.

CLOCK, Maximum (kHz) = 92,000 / Cable Length (ft)CW

Cable Length (ft)	50	100	200	300	500	1000
Max Freq (kHz)	1800	900	500	300	200	100

### SSI Timing

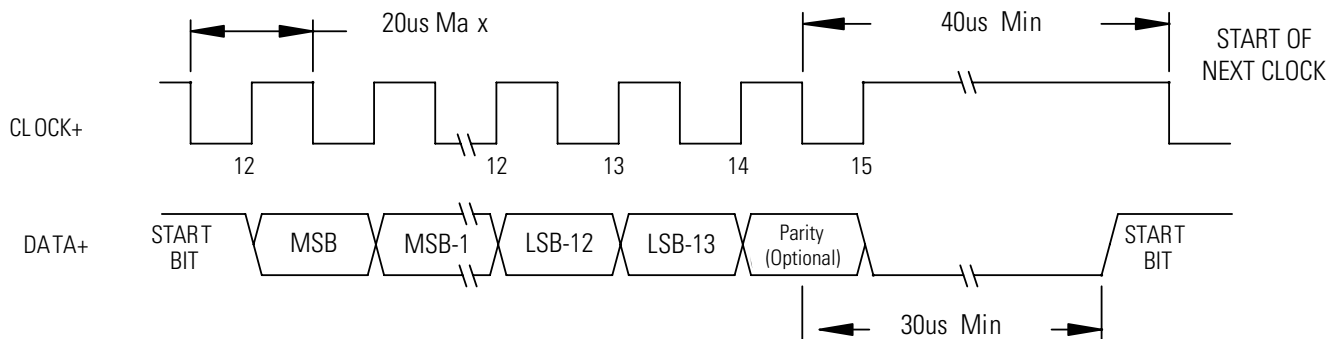



**Table 1 - Output Code and Terminations (12 & 13 Bit)**

	Parallel Code				Termination Type		
	Gray Code		Natural Binary		Binary Coded Decimal	Cable	Term Board H38
	12 Bit	13 Bit	12 Bit	13 Bit			
MSB	G <sub>11</sub>	G <sub>12</sub>	Z <sub>11</sub>	Z <sub>12</sub>	A <sub>0</sub>	WHT/BLK	1
	G <sub>10</sub>	G <sub>11</sub>	Z <sub>10</sub>	Z <sub>11</sub>	B <sub>0</sub>	WHT/BRN	2
	G <sub>9</sub>	G <sub>10</sub>	Z <sub>9</sub>	Z <sub>10</sub>	C <sub>0</sub>	WHT/RED	3
	G <sub>8</sub>	G <sub>9</sub>	Z <sub>8</sub>	Z <sub>9</sub>	D <sub>0</sub>	WHT/ORN	4
	G <sub>7</sub>	G <sub>8</sub>	Z <sub>7</sub>	Z <sub>8</sub>	A <sub>1</sub>	WHT/YEL	5
	G <sub>6</sub>	G <sub>7</sub>	Z <sub>6</sub>	Z <sub>7</sub>	B <sub>1</sub>	WHT/GRN	6
	G <sub>5</sub>	G <sub>6</sub>	Z <sub>5</sub>	Z <sub>6</sub>	C <sub>1</sub>	WHT/BLU	7
	G <sub>4</sub>	G <sub>5</sub>	Z <sub>4</sub>	Z <sub>5</sub>	D <sub>1</sub>	WHT/VIO	8
	G <sub>3</sub>	G <sub>4</sub>	Z <sub>3</sub>	Z <sub>4</sub>	A <sub>2</sub>	WHT/GRY	9
	G <sub>2</sub>	G <sub>3</sub>	Z <sub>2</sub>	Z <sub>3</sub>	B <sub>2</sub>	WHT	10
	G <sub>1</sub>	G <sub>2</sub>	Z <sub>1</sub>	Z <sub>2</sub>	C <sub>2</sub>	GRY/BLK	11
LSB <sub>12</sub>	G <sub>0</sub>	G <sub>1</sub>	Z <sub>0</sub>	Z <sub>1</sub>	D <sub>2</sub>	GRY/BRN	12
LSB <sub>13</sub>		G <sub>0</sub>		Z <sub>0</sub>	A <sub>3</sub>	GRY/RED	13
	0V (CIRCUIT COMMON)				B <sub>3</sub>	GRY/ORN	
	DIRECTION OF COUNT					ORN	18
	CASE GROUND					GRN	16
	0V (CIRCUIT COMMON)					BLK	15
	LATCH CONTROL					YEL	17
	+V (SUPPLY VOLTAGE)					RED	14
	SHIELD DRAIN					BARE	—

**Table 2 - SSI Output Termination Table**

	Cable Conn.	Term. Board
DATA+	YEL	4
DATA-	WHT/YEL	7
CLOCK+	BLU	5
CLOCK-	WHT/BLU	8
DIR CONTROL	ORN	6
CASE GROUND	GRN	1
CIRCUIT COMMON	BLK	2
+V SUPPLY VOLTAGE	RED	3
SHIELD DRAIN	BARE	—



## OPTIONS AND TABLES (CONTINUED)

**Direction of Count:** Standard is CW increasing when viewed from the shaft end. Pin 18 is normally HI (or N/C) and is pulled up internally to +V. To reverse the count direction, Pin 18 must be pulled LO (COMMON).

**Latch control:** Encoder outputs are active and provide continuous parallel position information when Pin 17 is HI (or N/C). Pin 17 is pulled up internally to +V. When Pin 17 is LO (COMMON) the encoder outputs are latched at the logic state that is present when the latch is applied and will stay latched until Pin 17 is no longer grounded.



## NOTES

See Doc. 01059-000 supplied with encoders for Important Installation and Usage notes summarized here.

### Encoder Installation

1. Environment: Hazardous Locations — UL Complies with UL and cUL requirements; CEN Shall comply with UL requirements plus CENELAC/ATEX plus IECEx standards
2. WARNING: Open all circuits prior to connecting this product to power and controller.
3. The installation must comply with NEC Class 2 circuits or with the regulations of the country of use.
4. AWG 14 - 22 stranded wire stripped to .25" [6.3mm] is recommended.
5. Use agency approved 105° C minimum rated cable/conductors housed within an approved rigid conduit.
6. Conduit runs must have a sealing fitting certified to 60079-0 Ex d IIB immediately at the entrance to the device.
7. Tightly close terminal block access cover prior to applying power.
8. For maximum bearing life, a flexible coupling is recommended between encoder shaft and driving shaft.
9. Thread sealant compound should be used for 1/2-14 fitting or cable gland to prevent ingress of contamination.

### During Use

1. Keep terminal block access tightly secured during use.
2. DO NOT loosen two 5/16" set screws at opposite face.

### Maintenance and Service

1. There are no user serviceable parts inside. Encoder must be returned to factory for service.
2. WARNING: Open all circuits to this product prior to opening access cover to disconnect wires.



Contact the factory for special versions, ex: special flanges, electronics, connections...

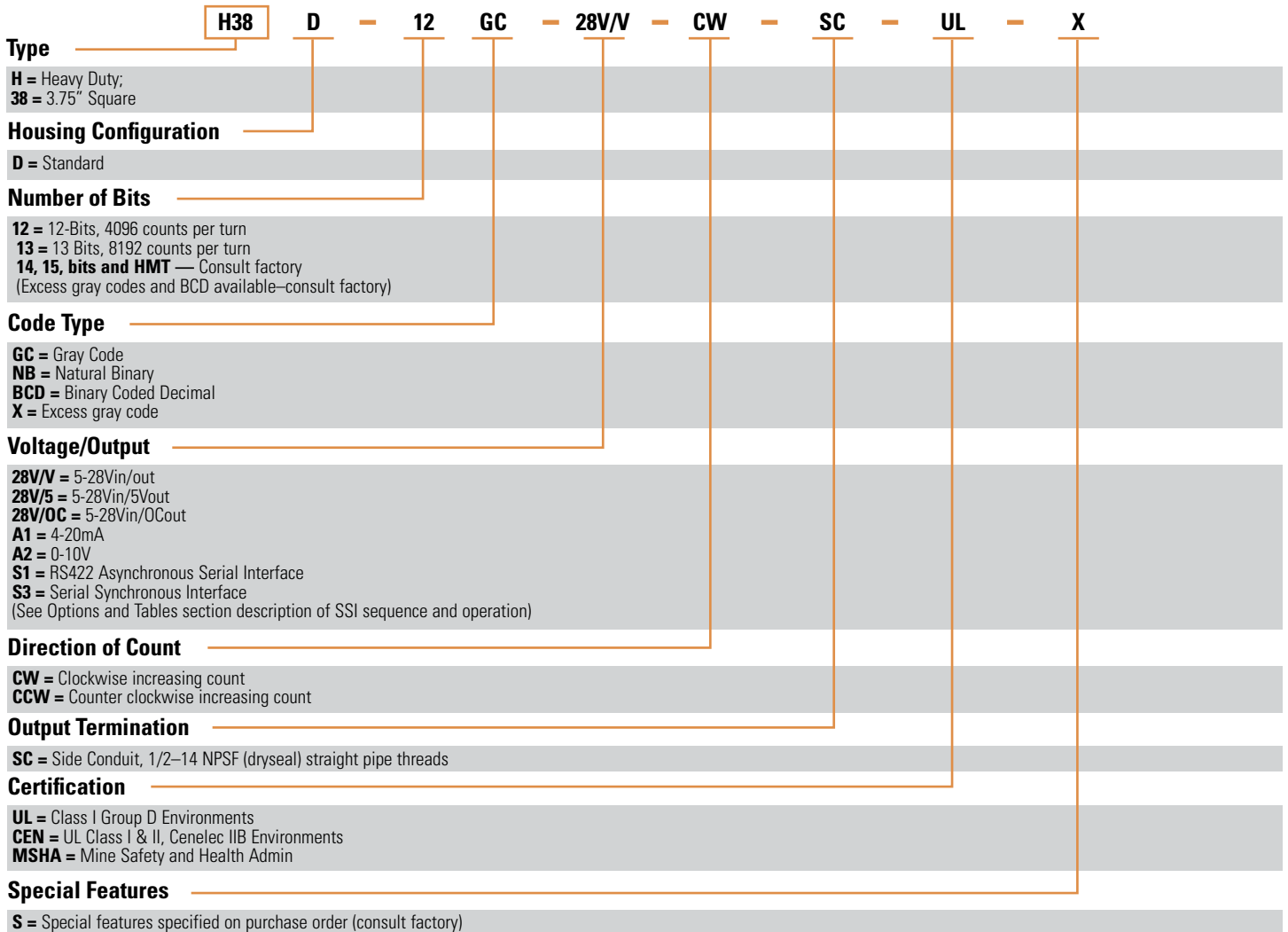

## AGENCY APPROVALS & CERTIFICATIONS



EN 61000-6-4 and EN 61000-6-2



II 2 G Ex d IIB T4 Gb



Class I, Group C & D;  
Class II Group E, F & G;  
Class I, Group D



Ex d IIB T4 Gb  
IECEX UL 14.0006X



The Mine Safety and Health Administration (MSHA) is an organization that operates in the United States and enforces compliance with safety and health standards in the Nation's mines. Consult factory for MSHA rated product.

Sensata Technologies, Inc. ("Sensata") data sheets are solely intended to assist designers ("Buyers") who are developing systems that incorporate Sensata products (also referred to herein as "components"). Buyer understands and agrees that Buyer remains responsible for using its independent analysis, evaluation and judgment in designing Buyer's systems and products. Sensata data sheets have been created using standard laboratory conditions and engineering practices. Sensata has not conducted any testing other than that specifically described in the published documentation for a particular data sheet. Sensata may make corrections, enhancements, improvements and other changes to its data sheets or components without notice.

Buyers are authorized to use Sensata data sheets with the Sensata component(s) identified in each particular data sheet. HOWEVER, NO OTHER LICENSE, EXPRESS OR IMPLIED, BY ESTOPPEL OR OTHERWISE TO ANY OTHER SENSATA INTELLECTUAL PROPERTY RIGHT, AND NO LICENSE TO ANY THIRD PARTY TECHNOLOGY OR INTELLECTUAL PROPERTY RIGHT, IS GRANTED HEREIN. SENSATA DATA SHEETS ARE PROVIDED "AS IS". SENSATA MAKES NO WARRANTIES OR REPRESENTATIONS WITH REGARD TO THE DATA SHEETS OR USE OF THE DATA SHEETS, EXPRESS, IMPLIED OR STATUTORY, INCLUDING ACCURACY OR COMPLETENESS. SENSATA DISCLAIMS ANY WARRANTY OF TITLE AND ANY IMPLIED WARRANTIES OF MERCHANTABILITY, FITNESS FOR A PARTICULAR PURPOSE, QUIET ENJOYMENT, QUIET POSSESSION, AND NON-INFRINGEMENT OF ANY THIRD PARTY INTELLECTUAL PROPERTY RIGHTS WITH REGARD TO SENSATA DATA SHEETS OR USE THEREOF.

All products are sold subject to Sensata's terms and conditions of sale supplied at [www.sensata.com](http://www.sensata.com) SENSATA ASSUMES NO LIABILITY FOR APPLICATIONS ASSISTANCE OR THE DESIGN OF BUYERS' PRODUCTS. BUYER ACKNOWLEDGES AND AGREES THAT IT IS SOLELY RESPONSIBLE FOR COMPLIANCE WITH ALL LEGAL, REGULATORY AND SAFETY-RELATED REQUIREMENTS CONCERNING ITS PRODUCTS, AND ANY USE OF SENSATA COMPONENTS IN ITS APPLICATIONS, NOTWITHSTANDING ANY APPLICATIONS-RELATED INFORMATION OR SUPPORT THAT MAY BE PROVIDED BY SENSATA.

Mailing Address: Sensata Technologies, Inc., 529 Pleasant Street, Attleboro, MA 02703, USA.

## CONTACT US

### Americas

+1 (800) 350 2727 – Option 1  
[sales.beisensors@sensata.com](mailto:sales.beisensors@sensata.com)  
**Europe, Middle East & Africa**  
+33 (3) 88 20 8080  
[position-info.eu@sensata.com](mailto:position-info.eu@sensata.com)

### Asia Pacific

[sales.isasia@list.sensata.com](mailto:sales.isasia@list.sensata.com)  
China +86 (21) 2306 1500  
Japan +81 (45) 277 7117  
Korea +82 (31) 601 2004  
India +91 (80) 67920890  
Rest of Asia +886 (2) 27602006  
ext 2808