

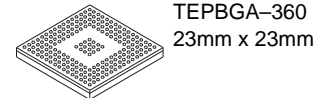

## MCF54455

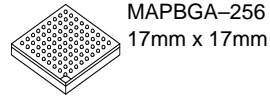

# MCF5445x ColdFire® Microprocessor Data Sheet

### Features

- Version 4 ColdFire® Core with MMU and EMAC
- Up to 410 Dhrystone 2.1 MIPS @ 266 MHz
- 16-KBytes instruction cache and 16-KBytes data cache
- 32-KBytes internal SRAM
- Support for booting from SPI-compatible flash, EEPROM, and FRAM devices
- Crossbar switch technology (XBS) for concurrent access to peripherals or RAM from multiple bus masters
- 16-channel DMA controller
- 16-bit 133-MHz DDR/mobile-DDR/DDR2 controller
- USB 2.0 On-the-Go controller with ULPI support
- 32-bit PCI controller @ 66MHz
- ATA/ATAPI controller
- 2 10/100 Ethernet MACs
- Coprocessor for acceleration of the DES, 3DES, AES, MD5, and SHA-1 algorithms
- Random number generator
- Synchronous serial interface (SSI)
- 4 periodic interrupt timers (PIT)
- 4 32-bit timers with DMA support
- DMA-supported serial peripheral interface (DSPI)
- 3 UARTs
- I<sup>2</sup>C bus interface

# Table of Contents

1	MCF5445x Family Comparison	4	5.9.1	Overshoot and Undershoot	28
2	Ordering Information	5	5.10	ULPI Timing Specifications	29
3	Hardware Design Considerations	5	5.11	SSI Timing Specifications	30
3.1	Analog Power Filtering	5	5.12	I <sup>2</sup> C Timing Specifications	32
3.2	Oscillator Power Filtering	6	5.13	Fast Ethernet Timing Specifications	33
3.3	Supply Voltage Sequencing	6	5.13.1	Receive Signal Timing Specifications	33
3.3.1	Power-Up Sequence	7	5.13.2	Transmit Signal Timing Specifications	34
3.3.2	Power-Down Sequence	7	5.13.3	Asynchronous Input Signal Timing Specifications	34
4	Pin Assignments and Reset States	7	5.13.4	MII Serial Management Timing Specifications	35
4.1	Signal Multiplexing	7	5.14	32-Bit Timer Module Timing Specifications	35
4.2	Pinout—256 MAPBGA	15	5.15	ATA Interface Timing Specifications	36
4.3	Pinout—360 TEPBGA	16	5.16	DSPI Timing Specifications	36
5	Electrical Characteristics	17	5.17	SBF Timing Specifications	38
5.1	Absolute Maximum Ratings	17	5.18	General Purpose I/O Timing Specifications	39
5.2	Thermal Characteristics	18	5.19	JTAG and Boundary Scan Timing	40
5.3	ESD Protection	19	5.20	Debug AC Timing Specifications	42
5.4	DC Electrical Specifications	19	6	Power Consumption	43
5.5	Clock Timing Specifications	20	7	Package Information	45
5.6	Reset Timing Specifications	22	8	Product Documentation	45
5.7	FlexBus Timing Specifications	23	9	Revision History	46
5.8	SDRAM AC Timing Characteristics	25			
5.9	PCI Bus Timing Specifications	27			

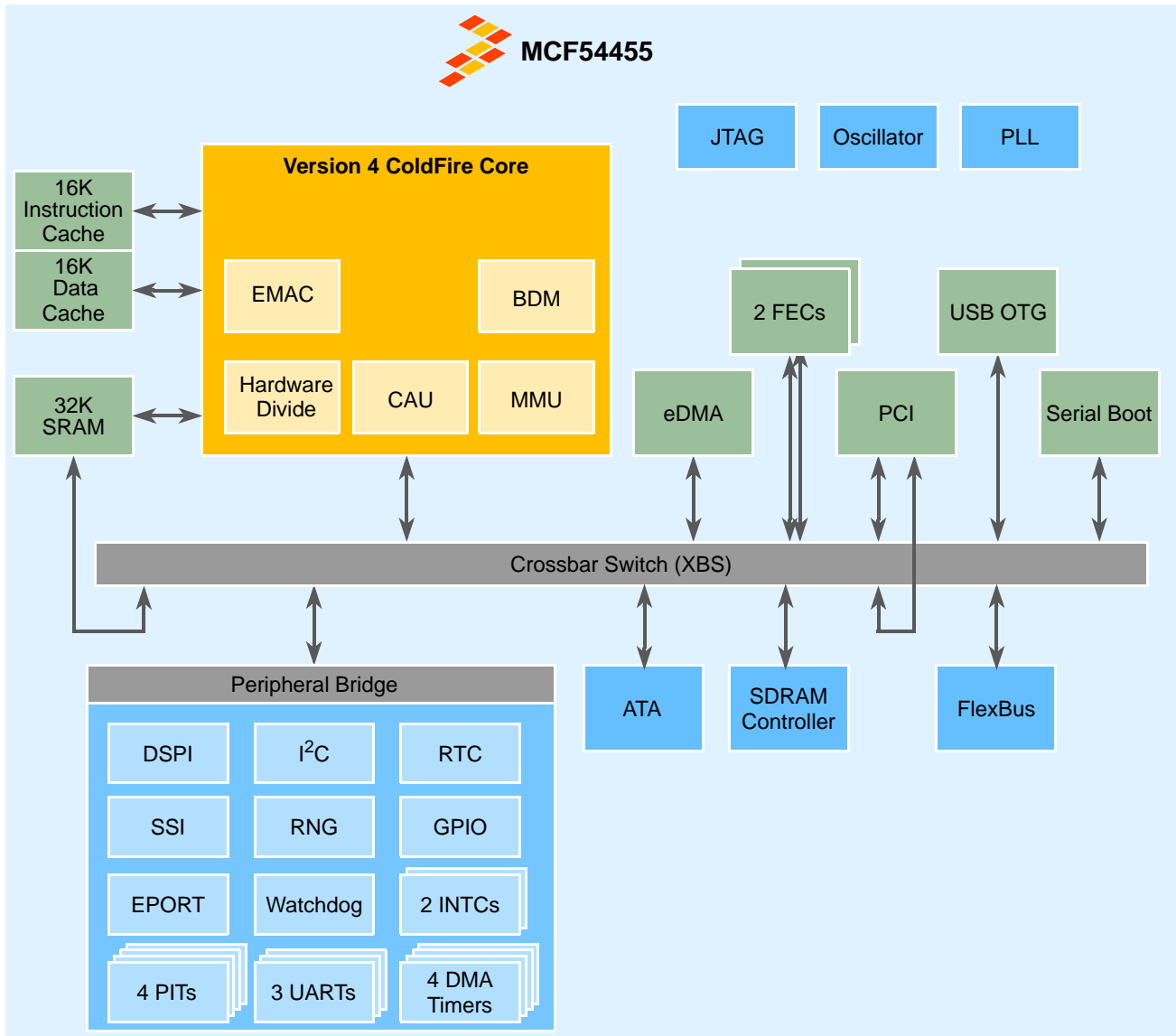

**LEGEND**

- |                       |   |                |   |
|-----------------------|---|----------------|---|
| <b>ATA</b>            | – Advanced Technology Attachment Controller | <b>INTC</b>    | – Interrupt controller                      |
| <b>BDM</b>            | – Background debug module                   | <b>JTAG</b>    | – Joint Test Action Group interface         |
| <b>CAU</b>            | – Cryptography acceleration unit            | <b>MMU</b>     | – Memory management unit                    |
| <b>DSPI</b>           | – DMA serial peripheral interface           | <b>PCI</b>     | – Peripheral Component Interconnect         |
| <b>eDMA</b>           | – Enhanced direct memory access             | <b>PIT</b>     | – Programmable interrupt timers             |
| <b>EMAC</b>           | – Enhance multiply-accumulate unit          | <b>PLL</b>     | – Phase locked loop module                  |
| <b>EPORT</b>          | – Edge port module                          | <b>RNG</b>     | – Random Number Generator                   |
| <b>FEC</b>            | – Fast Ethernet controller                  | <b>RTC</b>     | – Real time clock                           |
| <b>GPIO</b>           | – General Purpose Input/Output              | <b>SSI</b>     | – Synchronous Serial Interface              |
| <b>I<sup>2</sup>C</b> | – Inter-Integrated Circuit                  | <b>USB OTG</b> | – Universal Serial Bus On-the-Go controller |

**Figure 1. MCF54455 Block Diagram**

# 1 MCF5445x Family Comparison

The following table compares the various device derivatives available within the MCF5445x family.

**Table 1. MCF5445x Family Configurations**

Module	MCF54450	MCF54451	MCF54452	MCF54453	MCF54454	MCF54455
ColdFire Version 4 Core with EMAC (Enhanced Multiply-Accumulate Unit)	•	•	•	•	•	•
Core (System) Clock	up to 240 MHz		up to 266 MHz			
Peripheral Bus Clock (Core clock ÷ 2)	up to 120 MHz		up to 133 MHz			
External Bus Clock (Core clock ÷ 4)	up to 60 MHz		up to 66 MHz			
Performance (Dhrystone/2.1 MIPS)	up to 370		up to 410			
Independent Data/Instruction Cache	16 Kbytes each					
Static RAM (SRAM)	32 Kbytes					
PCI Controller	—	—	•	•	•	•
Cryptography Acceleration Unit (CAU)	—	•	—	•	—	•
ATA Controller	—	—	—	—	•	•
DDR SDRAM Controller	•	•	•	•	•	•
FlexBus External Interface	•	•	•	•	•	•
USB 2.0 On-the-Go	•	•	•	•	•	•
UTMI+ Low Pin Interface (ULPI)	•	•	•	•	•	•
Synchronous Serial Interface (SSI)	•	•	•	•	•	•
Fast Ethernet Controller (FEC)	1	1	2	2	2	2
UARTs	3	3	3	3	3	3
I <sup>2</sup> C	•	•	•	•	•	•
DSPI	•	•	•	•	•	•
Real Time Clock	•	•	•	•	•	•
32-bit DMA Timers	4	4	4	4	4	4
Watchdog Timer (WDT)	•	•	•	•	•	•
Periodic Interrupt Timers (PIT)	4	4	4	4	4	4
Edge Port Module (EPORT)	•	•	•	•	•	•
Interrupt Controllers (INTC)	2	2	2	2	2	2
16-channel Direct Memory Access (DMA)	•	•	•	•	•	•
General Purpose I/O (GPIO)	•	•	•	•	•	•
JTAG - IEEE <sup>®</sup> 1149.1 Test Access Port	•	•	•	•	•	•
Package	256 MAPBGA		360 TEPBGA			

## 2 Ordering Information

Table 2. Orderable Part Numbers

Part Number	Description	Package	Speed	Temperature
MCF54450CVM180	MCF54450 Microprocessor	256 MAPBGA	180 MHz	-40° to +85° C
MCF54450VM240			240 MHz	0° to +70° C
MCF54451CVM180	MCF54451 Microprocessor		180 MHz	-40° to +85° C
MCF54451VM240			240 MHz	0° to +70° C
MCF54452CVP200	MCF54452 Microprocessor	360 TEPBGA	200 MHz	-40° to +85° C
MCF54452VP266			266 MHz	0° to +70° C
MCF54453CVP200	MCF54453 Microprocessor		200 MHz	-40° to +85° C
MCF54453VP266			266 MHz	0° to +70° C
MCF54454CVP200	MCF54454 Microprocessor		200 MHz	-40° to +85° C
MCF54454VP266			266 MHz	0° to +70° C
MCF54455CVP200	MCF54455 Microprocessor		200 MHz	-40° to +85° C
MCF54455VP266			266 MHz	0° to +70° C

## 3 Hardware Design Considerations

### 3.1 Analog Power Filtering

To further enhance noise isolation, an external filter is strongly recommended for the analog  $V_{DD}$  pins ( $V_{DD\_A\_PLL}$ ,  $V_{DD\_RTC}$ ). The filter shown in Figure 2 should be connected between the board  $IV_{DD}$  and the analog pins. The resistor and capacitors should be placed as close to the dedicated analog  $V_{DD}$  pin as possible. The 10- $\Omega$  resistor in the given filter is required. Do not implement the filter circuit using only capacitors. The analog power pins draw very little current. Concerns regarding voltage loss across the 10-ohm resistor are not valid.

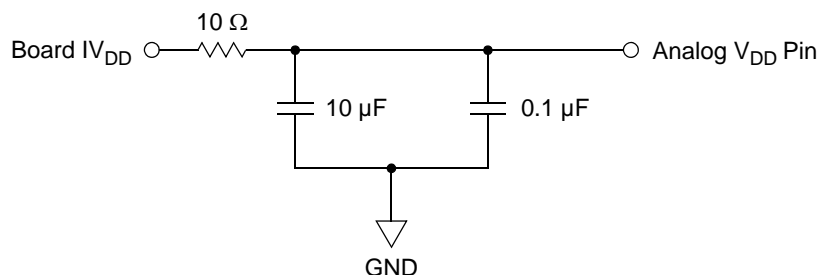

Figure 2. System Analog  $V_{DD}$  Power Filter

### 3.2 Oscillator Power Filtering

Figure 3 shows an example for isolating the oscillator power supply from the I/O supply (EVDD) and ground.

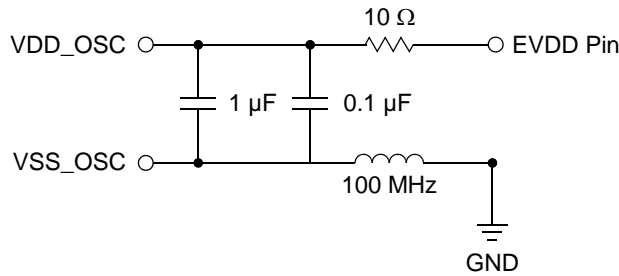
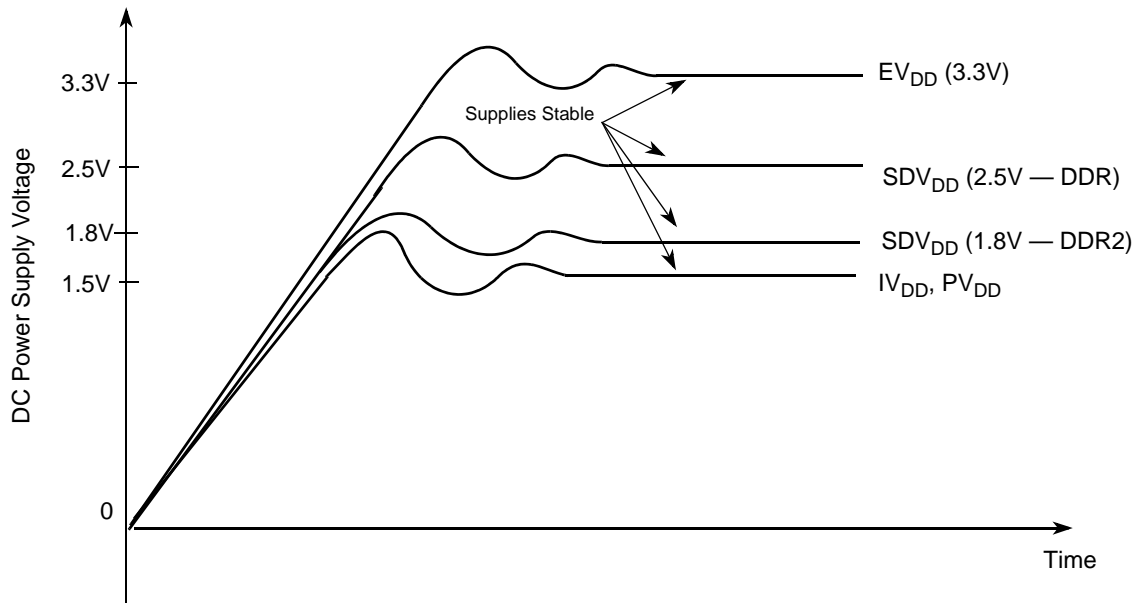

Figure 3. Oscillator Power Filter

### 3.3 Supply Voltage Sequencing

Figure 4 shows situations in sequencing the I/O  $V_{DD}$  ( $EV_{DD}$ ), SDRAM  $V_{DD}$  ( $SDV_{DD}$ ), PLL  $V_{DD}$  ( $PV_{DD}$ ), and internal logic/core  $V_{DD}$  ( $IV_{DD}$ ).



Notes:

- 1 Input voltage must not be greater than the supply voltage ( $EV_{DD}$ ,  $SDV_{DD}$ ,  $IV_{DD}$ , or  $PV_{DD}$ ) by more than 0.5V at any time, including during power-up.
- 2 Use 50 V/millisecond or slower rise time for all supplies.

Figure 4. Supply Voltage Sequencing and Separation Cautions

The relationship between  $SDV_{DD}$  and  $EV_{DD}$  is non-critical during power-up and power-down sequences.  $SDV_{DD}$  (2.5V or 1.8V) and  $EV_{DD}$  are specified relative to  $IV_{DD}$ .

### 3.3.1 Power-Up Sequence

If  $EV_{DD}/SDV_{DD}$  are powered up with the  $IV_{DD}$  at 0 V, the sense circuits in the I/O pads cause all pad output drivers connected to the  $EV_{DD}/SDV_{DD}$  to be in a high impedance state. There is no limit on how long after  $EV_{DD}/SDV_{DD}$  powers up before  $IV_{DD}$  must power up. The rise times on the power supplies should be slower than 50 V/millisecond to avoid turning on the internal ESD protection clamp diodes.

### 3.3.2 Power-Down Sequence

If  $IV_{DD}/PV_{DD}$  are powered down first, sense circuits in the I/O pads cause all output drivers to be in a high impedance state. There is no limit on how long after  $IV_{DD}$  and  $PV_{DD}$  power down before  $EV_{DD}$  or  $SDV_{DD}$  must power down. There are no requirements for the fall times of the power supplies.

## 4 Pin Assignments and Reset States

### 4.1 Signal Multiplexing

The following table lists all the MCF5445x pins grouped by function. The Dir column is the direction for the primary function of the pin only. Refer to [Section 4, “Pin Assignments and Reset States,”](#) for package diagrams. For a more detailed discussion of the MCF5445x signals, consult the *MCF54455 Reference Manual* (MCF54455RM).

#### NOTE

In this table and throughout this document, a single signal within a group is designated without square brackets (i.e.,  $FB\_AD23$ ), while designations for multiple signals within a group use brackets (i.e.,  $FB\_AD[23:21]$ ) and is meant to include all signals within the two bracketed numbers when these numbers are separated by a colon.

#### NOTE

The primary functionality of a pin is not necessarily its default functionality. Most pins that are muxed with GPIO default to their GPIO functionality. See [Table 3](#) for a list of the exceptions.

**Table 3. Special-Case Default Signal Functionality**

Pin	256 MAPBGA	360 TEPBGA
$FB\_AD[31:0]$	$FB\_AD[31:0]$ except when serial boot selects 0-bit boot port size.	
$FB\_BE/BWE[3:0]$	$FB\_BE/BWE[3:0]$	
$FB\_CS[3:1]$	$FB\_CS[3:1]$	
$FB\_OE$	$FB\_OE$	
$FB\_R/\overline{W}$	$FB\_R/\overline{W}$	
$FB\_TA$	$FB\_TA$	
$FB\_TS$	$FB\_TS$	

Table 3. Special-Case Default Signal Functionality (continued)

Pin	256 MAPBGA	360 TEPBGA
$\overline{\text{PCI\_GNT}}[3:0]$	GPIO	$\overline{\text{PCI\_GNT}}[3:0]$
$\overline{\text{PCI\_REQ}}[3:0]$	GPIO	$\overline{\text{PCI\_REQ}}[3:0]$
IRQ1	GPIO	$\overline{\text{PCI\_INTA}}$ and configured as an agent.
ATA_RESET	GPIO	ATA reset

Table 4. MCF5445x Signal Information and Muxing

Signal Name	GPIO	Alternate 1	Alternate 2	Pull-up (U) <sup>1</sup> Pull-down (D)	Direction <sup>2</sup>	Voltage Domain	MCF54450 MCF54451 256 MAPBGA	MCF54452 MCF54453 MCF54454 MCF54455 360 TEPBGA
<b>Reset</b>								
$\overline{\text{RESET}}$	—	—	—	U	I	EVDD	L4	Y18
$\overline{\text{RSTOUT}}$	—	—	—	—	O	EVDD	M15	B17
<b>Clock</b>								
EXTAL/PCI_CLK	—	—	—	—	I	EVDD	M16	A16
XTAL	—	—	—	U <sup>3</sup>	O	EVDD	L16	A17
<b>Mode Selection</b>								
BOOTMOD[1:0]	—	—	—	—	I	EVDD	M5, M7	AB17, AB21
<b>FlexBus</b>								
FB_AD[31:24]	PFBADH[7:0] <sup>4</sup>	FB_D[31:24]	—	—	I/O	EVDD	A14, A13, D12, C12, B12, A12, D11, C11	J2, K4, J1, K1–3, L1, L4
FB_AD[23:16]	PFBADMH[7:0] <sup>4</sup>	FB_D[23:16]	—	—	I/O	EVDD	B11, A11, D10, C10, B10, A10, D9, C9	L2, L3, M1–4, N1–2
FB_AD[15:8]	PFBADML[7:0] <sup>4</sup>	FB_D[15:8]	—	—	I/O	EVDD	B9, A9, D8, C8, B8, A8, D7, C7	P1–2, R1–3, P4, T1–2
FB_AD[7:0]	PFBADL[7:0] <sup>4</sup>	FB_D[7:0]	—	—	I/O	EVDD	B7, A7, D6, C6, B6, A6, D5, C5	T3–4, U1–3, V1–2, W1
$\overline{\text{FB\_BE/BWE}}[3:2]$	PBE[3:2]	FB_TSIZ[1:0]	—	—	O	EVDD	B5, A5	Y1, W2
$\overline{\text{FB\_BE/BWE}}[1:0]$	PBE[1:0]	—	—	—	O	EVDD	B4, A4	W3, Y2
FB_CLK	—	—	—	—	O	EVDD	B13	J3
$\overline{\text{FB\_CS}}[3:1]$	PCS[3:1]	—	—	—	O	EVDD	C2, D4, C3	W5, AA4, AB3
$\overline{\text{FB\_CS0}}$	—	—	—	—	O	EVDD	C4	Y4
$\overline{\text{FB\_OE}}$	PFBCTL3	—	—	—	O	EVDD	A2	AA1
$\overline{\text{FB\_R/W}}$	PFBCTL2	—	—	—	O	EVDD	B2	AA3
$\overline{\text{FB\_TA}}$	PFBCTL1	—	—	U	I	EVDD	B1	AB2



Table 4. MCF5445x Signal Information and Muxing (continued)

Signal Name	GPIO	Alternate 1	Alternate 2	Pull-up (U) <sup>1</sup> Pull-down (D)	Direction <sup>2</sup>	Voltage Domain	MCF54450 MCF54451 256 MAPBGA	MCF54452 MCF54453 MCF54454 MCF54455 360 TEPBGA
FB_TS	PFBCTL0	FB_ALE	FB_TBST	—	O	EVDD	A3	Y3
<b>PCI Controller<sup>5</sup></b>								
PCI_AD[31:0]	—	FB_A[31:0]	—	—	I/O	EVDD	—	C11, D11, A10, B10, J4, G2, G3, F1, D12, C12, B12, A11, B11, B9, D9, D10, A8, B8, A5, B5, A4, A3, B3, D4, D3, E3–E1, F3, C2, D2, C1
—	—	FB_A[23:0]	—	—	I/O	EVDD	K14–13, J15–13, H13–15, G15–13, F14–13, E15–13, D16, B16, C15, B15, C14, D15, C16, D14	—
PCI_CBE[3:0]	—	—	—	—	I/O	EVDD	—	G4, E4, D1, B1
PCI_DEVSEL	—	—	—	—	O	EVDD	—	F2
PCI_FRAME	—	—	—	—	I/O	EVDD	—	B2
PCI_GNT3	PPCI7	ATA_DMACK	—	—	O	EVDD	—	B7
PCI_GNT[2:1]	PPCI[6:5]	—	—	—	O	EVDD	—	C8, C9
PCI_GNT0/ PCI_EXTREQ	PPCI4	—	—	—	O	EVDD	—	A9
PCI_IDSEL	—	—	—	—	I	EVDD	—	D5
PCI_IRDY	—	—	—	—	I/O	EVDD	—	C3
PCI_PAR	—	—	—	—	I/O	EVDD	—	C4
PCI_PERR	—	—	—	—	I/O	EVDD	—	B4
PCI_REQ3	PPCI3	ATA_INTRQ	—	—	I	EVDD	—	C7
PCI_REQ[2:1]	PPCI[2:1]	—	—	—	I	EVDD	—	D7, C5
PCI_REQ0/ PCI_EXTGNT	PPCI0	—	—	—	I	EVDD	—	A2
PCI_RST	—	—	—	—	O	EVDD	—	B6
PCI_SERR	—	—	—	—	I/O	EVDD	—	A6
PCI_STOP	—	—	—	—	I/O	EVDD	—	A7
PCI_TRDY	—	—	—	—	I/O	EVDD	—	C10
<b>SDRAM Controller</b>								
SD_A[13:0]	—	—	—	—	O	SDVDD	R1, P1, N2, P2, R2, T2, M4, N3, P3, R3, T3, T4, R4, N4	V22, U20–22, T19–22, R20–22, N19, P20–21

Table 4. MCF5445x Signal Information and Muxing (continued)

Signal Name	GPIO	Alternate 1	Alternate 2	Pull-up (U) <sup>1</sup> Pull-down (D)	Direction <sup>2</sup>	Voltage Domain	MCF54450 MCF54451 256 MAPBGA	MCF54452 MCF54453 MCF54454 MCF54455 360 TEPBGA
SD_BA[1:0]	—	—	—	—	O	SDVDD	P4, T5	P22, P19
SD_CAS	—	—	—	—	O	SDVDD	T6	L19
SD_CKE	—	—	—	—	O	SDVDD	N5	N22
SD_CLK	—	—	—	—	O	SDVDD	T9	L22
SD_CLK	—	—	—	—	O	SDVDD	T8	M22
SD_CS[1:0]	—	—	—	—	O	SDVDD	P6, R6	L20, M20
SD_D[31:16]	—	—	—	—	I/O	SDVDD	N6, T7, N7, P7, R7, R8, P8, N8, N9, T10, R10, P10, N10, T11, R11, P11	L21, K22, K21, K20, J20, J19, J21, J22, H20, G22, G21, G20, G19, F22, F21, F20
SD_DM[3:2]	—	—	—	—	O	SDVDD	P9, N12	H21, E21
SD_DQS[3:2]	—	—	—	—	O	SDVDD	R9, N11	H22, E22
SD_RAS	—	—	—	—	O	SDVDD	P5	N21
SD_VREF	—	—	—	—	I	SDVDD	M8	M21
SD_WE	—	—	—	—	O	SDVDD	R5	N20
<b>External Interrupts Port<sup>6</sup></b>								
IRQ7	PIRQ7	—	—	—	I	EVDD	L1	ABB13
IRQ4	PIRQ4	—	SSI_CLKIN	—	I	EVDD	L2	ABB13
IRQ3	PIRQ3	—	—	—	I	EVDD	L3	AB14
IRQ1	PIRQ1	PCI_INTA	—	—	I	EVDD	F15	C6
<b>FEC0</b>								
FEC0_MDC	PFECI2C3	—	—	—	O	EVDD	F3	AB8
FEC0_MDIO	PFECI2C2	—	—	—	I/O	EVDD	F2	Y7
FEC0_COL	PFEC0H4	—	ULPI_DATA7	—	I	EVDD	E1	AB7
FEC0_CRS	PFEC0H0	—	ULPI_DATA6	—	I	EVDD	F1	AA7
FEC0_RXCLK	PFEC0H3	—	ULPI_DATA1	—	I	EVDD	G1	AA8
FEC0_RXDV	PFEC0H2	FEC0_RMII_ CRS_DV	—	—	I	EVDD	G2	Y8
FEC0_RXD[3:2]	PFEC0L[3:2]	—	ULPI_DATA[5:4]	—	I	EVDD	G3, G4	AB9, Y9
FEC0_RXD1	PFEC0L1	FEC0_RMII_RXD1	—	—	I	EVDD	H1	W9
FEC0_RXD0	PFEC0H1	FEC0_RMII_RXD0	—	—	I	EVDD	H2	AB10
FEC0_RXER	PFEC0L0	FEC0_RMII_RXER	—	—	I	EVDD	H3	AA10

Table 4. MCF5445x Signal Information and Muxing (continued)

Signal Name	GPIO	Alternate 1	Alternate 2	Pull-up (U) <sup>1</sup> Pull-down (D)	Direction <sup>2</sup>	Voltage Domain	MCF54450 MCF54451 256 MAPBGA	MCF54452 MCF54453 MCF54454 MCF54455 360 TEPBGA
FEC0_TXCLK	PFEC0H7	FEC0_RMII_REF_CLK	—	—	I	EVDD	H4	Y10
FEC0_TXD[3:2]	PFEC0L[7:6]	—	ULPI_DATA[3:2]	—	O	EVDD	J1, J2	W10, AB11
FEC0_TXD1	PFEC0L5	FEC0_RMII_TXD1	—	—	O	EVDD	J3	AA11
FEC0_TXD0	PFEC0H5	FEC0_RMII_TXD0	—	—	O	EVDD	J4	Y11
FEC0_TXEN	PFEC0H6	FEC0_RMII_TXEN	—	—	O	EVDD	K1	W11
FEC0_TXER	PFEC0L4	—	ULPI_DATA0	—	O	EVDD	K2	AB12
<b>FEC1</b>								
FEC1_MDC	PFEC1C5	—	ATA_DIOR	—	O	EVDD	—	W20
FEC1_MDIO	PFEC1C4	—	ATA_DIO $\overline{W}$	—	I/O	EVDD	—	Y22
FEC1_COL	PFEC1H4	—	ATA_DATA7	—	I	EVDD	—	AB18
FEC1_CRS	PFEC1H0	—	ATA_DATA6	—	I	EVDD	—	AA18
FEC1_RXCLK	PFEC1H3	—	ATA_DATA5	—	I	EVDD	—	W14
FEC1_RXDV	PFEC1H2	FEC1_RMII_CRS_DV	ATA_DATA15	—	I	EVDD	—	AB15
FEC1_RXD[3:2]	PFEC1L[3:2]	—	ATA_DATA[4:3]	—	I	EVDD	—	AA15, Y15
FEC1_RXD1	PFEC1L1	FEC1_RMII_RXD1	ATA_DATA14	—	I	EVDD	—	AA17
FEC1_RXD0	PFEC1H1	FEC1_RMII_RXD0	ATA_DATA13	—	I	EVDD	—	Y17
FEC1_RXER	PFEC1L0	FEC1_RMII_RXER	ATA_DATA12	—	I	EVDD	—	W17
FEC1_TXCLK	PFEC1H7	FEC1_RMII_REF_CLK	ATA_DATA11	—	I	EVDD	—	AB19
FEC1_TXD[3:2]	PFEC1L[7:6]	—	ATA_DATA[2:1]	—	O	EVDD	—	Y19, W18
FEC1_TXD1	PFEC1L5	FEC1_RMII_TXD1	ATA_DATA10	—	O	EVDD	—	AA19
FEC1_TXD0	PFEC1H5	FEC1_RMII_TXD0	ATA_DATA9	—	O	EVDD	—	Y20
FEC1_TXEN	PFEC1H6	FEC1_RMII_TXEN	ATA_DATA8	—	O	EVDD	—	AA21
FEC1_TXER	PFEC1L4	—	ATA_DATA0	—	O	EVDD	—	AA22
<b>USB On-the-Go</b>								
USB_DM	—	—	—	—	O	USB VDD	F16	A14
USB_DP	—	—	—	—	O	USB VDD	E16	A15
USB_VBUS_EN	PUSB1	USB_PULLUP	ULPI_NXT	—	O	USB VDD	E5	AA2
USB_VBUS_OC	PUSB0	—	ULPI_STP	UD <sup>7</sup>	I	USB VDD	B3	V4

Table 4. MCF5445x Signal Information and Muxing (continued)

Signal Name	GPIO	Alternate 1	Alternate 2	Pull-up (U) <sup>1</sup> Pull-down (D)	Direction <sup>2</sup>	Voltage Domain	MCF54450 MCF54451 256 MAPBGA	MCF54452 MCF54453 MCF54454 MCF54455 360 TEPBGA
<b>ATA</b>								
ATA_BUFFER_EN	PATAH5	—	—	—	O	EVDD	—	Y13
ATA_CS[1:0]	PATAH[4:3]	—	—	—	O	EVDD	—	W21, W22
ATA_DA[2:0]	PATAH[2:0]	—	—	—	O	EVDD	—	V19–21
ATA_RESET	PATAL2	—	—	—	O	EVDD	—	W13
ATA_DMARQ	PATAL1	—	—	—	I	EVDD	—	AA14
ATA_IORDY	PATAL0	—	—	—	I	EVDD	—	Y14
<b>Real Time Clock</b>								
EXTAL32K	—	—	—	—	I	EVDD	J16	A13
XTAL32K	—	—	—	—	O	EVDD	H16	A12
<b>SSI</b>								
SSI_MCLK	PSSI4	—	—	—	O	EVDD	T13	D20
SSI_BCLK	PSSI3	U1CTS	—	—	I/O	EVDD	R13	E19
SSI_FS	PSSI2	U1RTS	—	—	I/O	EVDD	P12	E20
SSI_RXD	PSSI1	U1RXD	—	UD	I	EVDD	T12	D21
SSI_TXD	PSSI0	U1TXD	—	UD	O	EVDD	R12	D22
<b>I<sup>2</sup>C</b>								
I2C_SCL	PFECI2C1	—	U2TXD	U	I/O	EVDD	K3	AA12
I2C_SDA	PFECI2C0	—	U2RXD	U	I/O	EVDD	K4	Y12
<b>DMA</b>								
DACK1	PDMA3	—	ULPI_DIR	—	O	EVDD	M14	C17
DREQ1	PDMA2	—	USB_CLKIN	U	I	EVDD	P16	C18
DACK0	PDMA1	DSPI_PCS3	—	—	O	EVDD	N15	A18
DREQ0	PDMA0	—	—	U	I	EVDD	N16	B18
<b>DSPI</b>								
DSPI_PCS5/PCSS	PDSP16	—	—	—	O	EVDD	N14	D18
DSPI_PCS2	PDSP15	—	—	—	O	EVDD	L13	A19
DSPI_PCS1	PDSP14	SBF_CS	—	—	O	EVDD	P14	B20
DSPI_PCS0/SS	PDSP13	—	—	U	I/O	EVDD	R16	D17
DSPI_SCK	PDSP12	SBF_CK	—	—	I/O	EVDD	R15	A20

Table 4. MCF5445x Signal Information and Muxing (continued)

Signal Name	GPIO	Alternate 1	Alternate 2	Pull-up (U) <sup>1</sup> Pull-down (D)	Direction <sup>2</sup>	Voltage Domain	MCF54450 MCF54451 256 MAPBGA	MCF54452 MCF54453 MCF54454 MCF54455 360 TEPBGA
DSPI_SIN	PDSP11	SBF_DI	—	8	I	EVDD	P15	B19
DSPI_SOUT	PDSP10	SBF_DO	—	—	O	EVDD	N13	C20
<b>UARTs</b>								
$\overline{U1CTS}$	PUART7	—	—	—	I	EVDD	—	V3
$\overline{U1RTS}$	PUART6	—	—	—	O	EVDD	—	U4
U1RXD	PUART5	—	—	—	I	EVDD	—	P3
U1TXD	PUART4	—	—	—	O	EVDD	—	N3
$\overline{U0CTS}$	PUART3	—	—	—	I	EVDD	M3	Y16
$\overline{U0RTS}$	PUART2	—	—	—	O	EVDD	M2	AA16
U0RXD	PUART1	—	—	—	I	EVDD	N1	AB16
U0TXD	PUART0	—	—	—	O	EVDD	M1	W15
<b>Note:</b> The UART1 and UART 2 signals are multiplexed on the DMA timers and I2C pins.								
<b>DMA Timers</b>								
DT3IN	PTIMER3	DT3OUT	U2RXD	—	I	EVDD	C13	H2
DT2IN	PTIMER2	DT2OUT	U2TXD	—	I	EVDD	D13	H1
DT1IN	PTIMER1	DT1OUT	$\overline{U2CTS}$	—	I	EVDD	B14	H3
DT0IN	PTIMER0	DT0OUT	$\overline{U2RTS}$	—	I	EVDD	A15	G1
<b>BDM/JTAG<sup>9</sup></b>								
PSTDDATA[7:0]	—	—	—	—	O	EVDD	E2, D1, F4, E3, D2, C1, E4, D3	AA6, AB6, AB5, W6, Y6, AA5, AB4, Y5
JTAG_EN	—	—	—	D	I	EVDD	M11	C21
PSTCLK	—	TCLK	—	—	I	EVDD	P13	C22
DSI	—	TDI	—	U	I	EVDD	T15	C19
DSO	—	TDO	—	—	O	EVDD	T14	A21
$\overline{BKPT}$	—	TMS	—	U	I	EVDD	R14	B21
DSCLK	—	$\overline{TRST}$	—	U	I	EVDD	M13	B22
<b>Test</b>								
TEST	—	—	—	D	I	EVDD	M6	AB20
PLLTEST	—	—	—	—	O	EVDD	K16	D15

Table 4. MCF5445x Signal Information and Muxing (continued)

Signal Name	GPIO	Alternate 1	Alternate 2	Pull-up (U) <sup>1</sup> Pull-down (D)	Direction <sup>2</sup>	Voltage Domain	MCF54450 MCF54451 256 MAPBGA	MCF54452 MCF54453 MCF54454 MCF54455 360 TEPBGA
<b>Power Supplies</b>								
IVDD	—	—	—	—	—	—	E6–12, F5, F12	D6, D8, D14, F4, H4, N4, R4, W4, W7, W8, W12, W16, W19
EVDD	—	—	—	—	—	—	G5, G12, H5, H12, J5, J12, K5, K12, L5–6, L12	D13, D19, G8, G11, G14, G16, J7, J16, L7, L16, N16, P7, R16, T8, T12, T14, T16
SD_VDD	—	—	—	—	—	—	L7–11, M9, M10	F19, H19, K19, M19, R19, U19
VDD_OSC	—	—	—	—	—	—	L14	B16
VDD_A_PLL	—	—	—	—	—	—	K15	C14
VDD_RTC	—	—	—	—	—	—	M12	C13
VSS	—	—	—	—	—	—	A1, A16, F6–11, G6–11, H6–11, J6– 11, K6–11, T1, T16	A1, A22, B14, G7, G9–10, G12–13, G15, H7, H16, J9– 14, K7, K9–14, K16, L9–14, M7, M9–M14, M16, N7, N9–14, P9–14, P16, R7, T7, T9– 11, T13, T15, AB1, AB22
VSS_OSC	—	—	—	—	—	—	L15	C16

<sup>1</sup> Pull-ups are generally only enabled on pins with their primary function, except as noted.

<sup>2</sup> Refers to pin's primary function.

<sup>3</sup> Enabled only in oscillator bypass mode (internal crystal oscillator is disabled).

<sup>4</sup> Serial boot must select 0-bit boot port size to enable the GPIO mode on these pins.

<sup>5</sup> When the PCI is enabled, all PCI bus pins come up configured as such. This includes the PCI\_GNT and PCI\_REQ lines, which have GPIO. The IRQ1/PCI\_INTA signal is a special case. It comes up as PCI\_INTA when booting as a PCI agent and as GPIO when booting as a PCI host.

For the 360 TEPBGA, booting with PCI disabled results in all dedicated PCI pins being safe-stated. The PCI\_GNT and PCI\_REQ lines and IRQ1/PCI\_INTA come up as GPIO.

<sup>6</sup> GPIO functionality is determined by the edge port module. The pin multiplexing and control module is only responsible for assigning the alternate functions.

<sup>7</sup> Depends on programmed polarity of the USB\_VBUS\_OC signal.

<sup>8</sup> Pull-up when the serial boot facility (SBF) controls the pin

<sup>9</sup> If JTAG\_EN is asserted, these pins default to Alternate 1 (JTAG) functionality. The pin multiplexing and control module is not responsible for assigning these pins.

## 4.2 Pinout—256 MAPBGA

The pinout for the MCF54450 and MCF54451 packages are shown below.

	1	2	3	4	5	6	7	8	9	10	11	12	13	14	15	16		
A	VSS	FB_OE	FB_TS	FB_BE/BWE0	FB_BE/BWE2	FB_AD 2	FB_AD 6	FB_AD 10	FB_AD 14	FB_AD 18	FB_AD 22	FB_AD 26	FB_AD 30	FB_AD 31	T0IN	VSS	A	
B	FB_TA	FB_R/W	USB_VBUS_OC	FB_BE/BWE1	FB_BE/BWE3	FB_AD 3	FB_AD 7	FB_AD 11	FB_AD 15	FB_AD 19	FB_AD 23	FB_AD 27	FB_CLK	T1IN	FB_A 4	FB_A 6	B	
C	PST_DDATA2	FB_CS3	FB_CS1	FB_CS0	FB_AD 0	FB_AD 4	FB_AD 8	FB_AD 12	FB_AD 16	FB_AD 20	FB_AD 24	FB_AD 28	T3IN	FB_A 3	FB_A 5	FB_A 1	C	
D	PST_DDATA6	PST_DDATA3	PST_DDATA0	FB_CS2	FB_AD 1	FB_AD 5	FB_AD 9	FB_AD 13	FB_AD 17	FB_AD 21	FB_AD 25	FB_AD 29	T2IN	FB_A 0	FB_A 2	FB_A 7	D	
E	FEC0_COL	PST_DDATA7	PST_DDATA4	PST_DDATA1	USB_VBUS_EN	IVDD	IVDD	IVDD	IVDD	IVDD	IVDD	IVDD	IVDD	FB_A 8	FB_A 9	FB_A 10	USB_DP	E
F	FEC0_CRS	FEC0_MDIO	FEC0_MDC	PST_DDATA5	IVDD	VSS	VSS	VSS	VSS	VSS	VSS	IVDD	FB_A 11	FB_A 12	IRQ_1	USB_DM	F	
G	FEC0_RXCLK	FEC0_RXDV	FEC0_RXD3	FEC0_RXD2	EVDD	VSS	VSS	VSS	VSS	VSS	VSS	EVDD	FB_A 13	FB_A 14	FB_A 15	NC	G	
H	FEC0_RXD1	FEC0_RXD0	FEC0_RXER	FEC0_TXCLK	EVDD	VSS	VSS	VSS	VSS	VSS	VSS	EVDD	FB_A 18	FB_A 17	FB_A 16	XTAL 32K	H	
J	FEC0_TXD3	FEC0_TXD2	FEC0_TXD1	FEC0_TXD0	EVDD	VSS	VSS	VSS	VSS	VSS	VSS	EVDD	FB_A 19	FB_A 20	FB_A 21	EXTAL 32K	J	
K	FEC0_TXEN	FEC0_TXER	I2C_SCL	I2C_SDA	EVDD	VSS	VSS	VSS	VSS	VSS	VSS	EVDD	FB_A 22	FB_A 23	VDD_A_PLL	PLL TEST	K	
L	IRQ_7	IRQ_4	IRQ_3	RESET	EVDD	EVDD	SDVDD	SDVDD	SDVDD	SDVDD	SDVDD	EVDD	DSPI_PCS2	VDD_OSC	VSS_OSC	XTAL	L	
M	U0TXD	U0RTS	U0CTS	SD_A7	BOOT_MOD1	TEST	BOOT_MOD0	SD_VREF	SDVDD	SDVDD	JTAG_EN	VDD_RTC	TRST	DACK1	RST_OUT	EXTAL	M	
N	U0RXD	SD_A11	SD_A6	SD_A0	SD_CKE	SD_D31	SD_D29	SD_D24	SD_D23	SD_D19	SD_DQS2	SD_DM2	DSPI_SOUT	DSPI_PCS5	DACK0	DREQ0	N	
P	SD_A12	SD_A10	SD_A5	SD_BA1	SD_RAS	SD_CS1	SD_D28	SD_D25	SD_DM3	SD_D20	SD_D16	SSI_FS	TCLK	DSPI_PCS1	DSPI_SIN	DREQ1	P	
R	SD_A13	SD_A9	SD_A4	SD_A1	SD_WE	SD_CS0	SD_D27	SD_D26	SD_DQS3	SD_D21	SD_D17	SSI_TXD	SSI_BCLK	TMS	DSPI_SCK	DSPI_PCS0	R	
T	VSS	SD_A8	SD_A3	SD_A2	SD_BA0	SD_CAS	SD_D30	SD_CLK	SD_CLK	SD_D22	SD_D18	SSI_RXD	SSI_MCLK	TDO	TDI	VSS	T	

Figure 5. MCF54450 and MCF54451 Pinout (256 MAPBGA)

### 4.3 Pinout—360 TEPBGA

The pinout for the MCF54452, MCF54453, MCF54454, and MCF54455 packages are shown below.

	1	2	3	4	5	6	7	8	9	10	11	12	13	14	15	16	17	18	19	20	21	22	
A	GND	PCI_REQ0	PCI_AD10	PCI_AD11	PCI_AD13	PCI_SERR	PCI_STOP	PCI_AD15	PCI_GNT0	PCI_AD29	PCI_AD20	XTAL_32K	EXTAL_32K	USB_DM	USB_DP	EXTAL	XTAL	DACK0	DSPL_PCS2	DSPL_SCK	TDO	GND	A
B	PCI_CBE0	PCI_FRAME	PCI_AD9	PCI_PERR	PCI_AD12	PCI_RST	PCI_GNT3	PCI_AD14	PCI_AD18	PCI_AD28	PCI_AD19	PCI_AD21	NC	GND	NC	VDD_OSC	RST_OUT	DREQ0	DSPL_SIN	DSPL_PCS1	TMS	TRST	B
C	PCI_AD0	PCI_AD2	PCI_IRDY	PCI_PAR	PCI_REQ1	IRQ1	PCI_REQ3	PCI_GNT2	PCI_GNT1	PCI_TRDY	PCI_AD31	PCI_AD22	VDD_RTC	VDD_A_PLL	NC	VSS_OSC	DACKT	DREQ1	TDI	DSPL_SOUT	JTAG_EN	TCLK	C
D	PCI_CBE1	PCI_AD1	PCI_AD7	PCI_AD8	PCI_IDSEL	IVDD	PCI_REQ2	IVDD	PCI_AD17	PCI_AD16	PCI_AD30	PCI_AD23	EVDD	IVDD	PLL_TEST	NC	DSPL_PCS0	DSPL_PCS5	EVDD	SSI_MCLK	SSI_RXD	SSI_TXD	D
E	PCI_AD4	PCI_AD5	PCI_AD6	PCI_CBE2															SSI_BCLK	SSI_FS	SD_DM2	SD_DQS2	E
F	PCI_AD24	PCI_DE_VSEL	PCI_AD3	IVDD															SDVDD	SD_D16	SD_D17	SD_D18	F
G	T0IN	PCI_AD26	PCI_AD25	PCI_CBE3															SD_D19	SD_D20	SD_D21	SD_D22	G
H	T2IN	T3IN	T1IN	IVDD															SDVDD	SD_D23	SD_DM3	SD_DQS3	H
J	FB_AD_29	FB_AD_31	FB_CLK	PCI_AD27															SD_D26	SD_D27	SD_D25	SD_D24	J
K	FB_AD_28	FB_AD_27	FB_AD_26	FB_AD_30															SDVDD	SD_D28	SD_D29	SD_D30	K
L	FB_AD_25	FB_AD_23	FB_AD_22	FB_AD_24															SD_CAS	SD_CS1	SD_D31	SD_CLK	L
M	FB_AD_21	FB_AD_20	FB_AD_19	FB_AD_18															SDVDD	SD_CS0	SD_VREF	SD_CLK	M
N	FB_AD_17	FB_AD_16	U1TXD	IVDD															SD_A2	SD_WE	SD_RAS	SD_CKE	N
P	FB_AD_15	FB_AD_14	U1RXD	FB_AD_10															SD_BA0	SD_A1	SD_A0	SD_BA1	P
R	FB_AD_13	FB_AD_12	FB_AD_11	IVDD															SDVDD	SD_A5	SD_A4	SD_A3	R
T	FB_AD_9	FB_AD_8	FB_AD_7	FB_AD_6															SD_A9	SD_A8	SD_A7	SD_A6	T
U	FB_AD_5	FB_AD_4	FB_AD_3	U1RTS															SDVDD	SD_A12	SD_A11	SD_A10	U
V	FB_AD_2	FB_AD_1	U1CTS	USB_VBUS_OC															ATA_DA2	ATA_DA1	ATA_DA0	SD_A13	V
W	FB_AD_0	FB_BE/BWE2	FB_BE/BWE1	IVDD	FB_CS3	PST_DDATA4	IVDD	IVDD	FEC0_RXD1	FEC0_TXD3	FEC0_TXEN	IVDD	ATA_RESET	FEC1_RXCLK	U0TXD	IVDD	FEC1_RXER	FEC1_TXD2	IVDD	FEC1_MDC	ATA_CS1	ATA_CS0	W
Y	FB_BE/BWE3	FB_BE/BWE0	FB_TS	FB_CS0	PST_DDATA0	PST_DDATA3	FEC0_MDIO	FEC0_RXDV	FEC0_RXD2	FEC0_TXCLK	FEC0_TXD0	I2C_SDA	ATA_BUFFER_EN	ATA_IORDY	FEC1_RXD2	U0CTS	FEC1_RXD0	RESET	FEC1_TXD3	FEC1_TXD0	NC	FEC1_MDIO	Y
AA	FB_OE	USB_VBUS_EN	FB_RW	FB_CS2	PST_DDATA2	PST_DDATA7	FEC0_CRS	FEC0_RXCLK	NC	FEC0_RXER	FEC0_TXD1	I2C_SCL	IRQ4	ATA_DMARQ	FEC1_RXD3	U0RTS	FEC1_RXD1	FEC1_CRS	FEC1_TXD1	NC	FEC1_TXEN	FEC1_TXER	AA
AB	GND	FB_TA	FB_CS1	PST_DDATA1	PST_DDATA5	PST_DDATA6	FEC0_COL	FEC0_MDC	FEC0_RXD3	FEC0_RXD0	FEC0_TXD2	FEC0_TXER	IRQ7	IRQ3	FEC1_RXDV	U0RXD	BOOT_MOD1	FEC1_COL	FEC1_TXCLK	TEST	BOOT_MOD0	GND	AB

Figure 6. MCF54452, MCF54453, MCF54454, and MCF54455 Pinout (360 TEPBGA)



## 5 Electrical Characteristics

This document contains electrical specification tables and reference timing diagrams for the MCF54455 microprocessor. This section contains detailed information on DC/AC electrical characteristics and AC timing specifications.

The electrical specifications are preliminary and from previous designs or design simulations. These specifications may not be fully tested or guaranteed at this early stage of the product life cycle. However, for production silicon, these specifications will be met. Finalized specifications will be published after complete characterization and device qualifications have been completed.

### NOTE

The parameters specified in this MCU document supersede any values found in the module specifications.

### 5.1 Absolute Maximum Ratings

Table 5. Absolute Maximum Ratings<sup>1, 2</sup>

Rating	Symbol	Pin Name	Value	Units
External I/O pad supply voltage	$EV_{DD}$	EVDD	-0.3 to +4.0	V
Internal oscillator supply voltage	$OSCV_{DD}$	VDD_OSC	-0.3 to +4.0	V
Real-time clock supply voltage	$RTCV_{DD}$	VDD_RTC	-0.5 to +2.0	V
Internal logic supply voltage	$IV_{DD}$	IVDD	-0.5 to +2.0	V
SDRAM I/O pad supply voltage	$SDV_{DD}$	SD_VDD	-0.3 to +4.0	V
PLL supply voltage	$PV_{DD}$	VDD_A_PLL	-0.5 to +2.0	V
Digital input voltage <sup>3</sup>	$V_{IN}$	—	-0.3 to +3.6	V
Instantaneous maximum current Single pin limit (applies to all pins) <sup>3, 4, 5</sup>	$I_{DD}$	—	25	mA
Operating temperature range (packaged)	$T_A$ ( $T_L - T_H$ )	—	-40 to +85	°C
Storage temperature range	$T_{stg}$	—	-55 to +150	°C

<sup>1</sup> Functional operating conditions are given in Table 8. Absolute maximum ratings are stress ratings only, and functional operation at the maximum is not guaranteed. Continued operation at these levels may affect device reliability or cause permanent damage to the device.

<sup>2</sup> This device contains circuitry protecting against damage due to high static voltage or electrical fields. However, it is advised that normal precautions be taken to avoid application of any voltages higher than maximum-rated voltages to this high-impedance circuit. Reliability of operation is enhanced if unused inputs are tied to an appropriate logic voltage level (e.g.,  $V_{SS}$  or  $EV_{DD}$ ).

<sup>3</sup> Input must be current limited to the value specified. To determine the value of the required current-limiting resistor, calculate resistance values for positive and negative clamp voltages, and then use the larger of the two values.

<sup>4</sup> All functional non-supply pins are internally clamped to  $V_{SS}$  and  $EV_{DD}$ .

<sup>5</sup> Power supply must maintain regulation within operating  $EV_{DD}$  range during instantaneous and operating maximum current conditions. If positive injection current ( $V_{in} > EV_{DD}$ ) is greater than  $I_{DD}$ , the injection current may flow out of  $EV_{DD}$  and could result in external power supply going out of regulation. Ensure the external  $EV_{DD}$  load shunts current greater than maximum injection current. This is the greatest risk when the MPU is not consuming power (ex; no clock). The power supply must maintain regulation within operating  $EV_{DD}$  range during instantaneous and operating maximum current conditions.

## 5.2 Thermal Characteristics

Table 6. Thermal Characteristics

Characteristic		Symbol	256 MAPBGA	360 TEPBGA	Unit
Junction to ambient, natural convection	Four layer board (2s2p)	$\theta_{JA}$	29 <sup>1,2</sup>	24 <sup>1,2</sup>	°C/W
Junction to ambient (@200 ft/min)	Four layer board (2s2p)	$\theta_{JMA}$	25 <sup>1,2</sup>	21 <sup>1,2</sup>	°C/W
Junction to board		$\theta_{JB}$	18 <sup>3</sup>	15 <sup>3</sup>	°C/W
Junction to case		$\theta_{JC}$	10 <sup>4</sup>	11 <sup>4</sup>	°C/W
Junction to top of package		$\Psi_{jt}$	2 <sup>1,5</sup>	2 <sup>1,5</sup>	°C/W
Maximum operating junction temperature		$T_j$	105	105	°C

<sup>1</sup>  $\theta_{JMA}$  and  $\Psi_{jt}$  parameters are simulated in conformance with EIA/JESD Standard 51-2 for natural convection. NXP recommends the use of  $\theta_{JMA}$  and power dissipation specifications in the system design to prevent device junction temperatures from exceeding the rated specification. System designers should be aware that device junction temperatures can be significantly influenced by board layout and surrounding devices. Conformance to the device junction temperature specification can be verified by physical measurement in the customer's system using the  $\Psi_{jt}$  parameter, the device power dissipation, and the method described in EIA/JESD Standard 51-2.

<sup>2</sup> Per JEDEC JESD51-6 with the board horizontal.

<sup>3</sup> Thermal resistance between the die and the printed circuit board in conformance with JEDEC JESD51-8. Board temperature is measured on the top surface of the board near the package.

<sup>4</sup> Thermal resistance between the die and the case top surface as measured by the cold plate method (MIL SPEC-883 Method 1012.1).

<sup>5</sup> Thermal characterization parameter indicating the temperature difference between package top and the junction temperature per JEDEC JESD51-2. When Greek letters are not available, the thermal characterization parameter is written in conformance with Psi-JT.

The average chip-junction temperature ( $T_j$ ) in °C can be obtained from:

$$T_j = T_A + (P_D \times \theta_{JMA}) \quad \text{Eqn. 1}$$

Where:

$T_A$	= Ambient Temperature, °C
$\theta_{JMA}$	= Package Thermal Resistance, Junction-to-Ambient, °C/W
$P_D$	= $P_{INT} + P_{I/O}$
$P_{INT}$	= $I_{DD} \times IV_{DD}$ , Watts - Chip Internal Power
$P_{I/O}$	= Power Dissipation on Input and Output Pins - User Determined

For most applications  $P_{I/O} < P_{INT}$  and can be ignored. An approximate relationship between  $P_D$  and  $T_j$  (if  $P_{I/O}$  is neglected) is:

$$P_D = \frac{K}{(T_j + 273^\circ C)} \quad \text{Eqn. 2}$$

Solving equations 1 and 2 for K gives:

$$K = P_D \times (T_A \times 273^\circ C) + \theta_{JMA} \times P_D^2 \quad \text{Eqn. 3}$$

where  $K$  is a constant pertaining to the particular part.  $K$  can be determined from Equation 3 by measuring  $P_D$  (at equilibrium) for a known  $T_A$ . Using this value of  $K$ , the values of  $P_D$  and  $T_J$  can be obtained by solving Equation 1 and Equation 2 iteratively for any value of  $T_A$ .

## 5.3 ESD Protection

Table 7. ESD Protection Characteristics<sup>1, 2</sup>

Characteristics	Symbol	Value	Units
ESD Target for Human Body Model	HBM	2000	V

<sup>1</sup> All ESD testing is in conformity with CDF-AEC-Q100 Stress Test Qualification for Automotive Grade Integrated Circuits.

<sup>2</sup> A device is defined as a failure if after exposure to ESD pulses the device no longer meets the device specification requirements. Complete DC parametric and functional testing is performed per applicable device specification at room temperature followed by hot temperature, unless specified otherwise in the device specification.

## 5.4 DC Electrical Specifications

Table 8. DC Electrical Specifications

Characteristic	Symbol	Min	Max	Units
Internal logic supply voltage <sup>1</sup>	$V_{DD}$	1.35	1.65	V
PLL analog operation voltage range <sup>1</sup>	$PV_{DD}$	1.35	1.65	V
External I/O pad supply voltage	$EV_{DD}$	3.0	3.6	V
Internal oscillator supply voltage	$OSCV_{DD}$	3.0	3.6	V
Real-time clock supply voltage	$RTCV_{DD}$	1.35	1.65	V
SDRAM I/O pad supply voltage — DDR mode	$SDV_{DD}$	2.25	2.75	V
SDRAM I/O pad supply voltage — DDR2 mode	$SDV_{DD}$	1.7	1.9	V
SDRAM I/O pad supply voltage — Mobile DDR mode	$SDV_{DD}$	1.7	1.9	V
SDRAM input reference voltage	$SDV_{REF}$	$0.49 \times SDV_{DD}$	$0.51 \times SDV_{DD}$	V
Input High Voltage	$V_{IH}$	$0.7 \times EV_{DD}$	3.65	V
Input Low Voltage	$V_{IL}$	$V_{SS} - 0.3$	$0.35 \times EV_{DD}$	V
Input Hysteresis	$V_{HYS}$	$0.06 \times EV_{DD}$	—	mV
Input Leakage Current <sup>2</sup> $V_{in} = V_{DD}$ or $V_{SS}$ , Input-only pins	$I_{in}$	-2.5	2.5	$\mu A$
Input Leakage Current <sup>3</sup> $V_{in} = V_{DD}$ or $V_{SS}$ , Input-only pins	$I_{in}$	-5	5	$\mu A$
High Impedance (Off-State) Leakage Current <sup>4</sup> $V_{in} = V_{DD}$ or $V_{SS}$ , All input/output and output pins	$I_{OZ}$	-10.0	10.0	$\mu A$
Output High Voltage (All input/output and all output pins) $I_{OH} = -5.0$ mA	$V_{OH}$	$0.85 \times EV_{DD}$	—	V
Output Low Voltage (All input/output and all output pins) $I_{OL} = 5.0$ mA	$V_{OL}$	—	$0.15 \times EV_{DD}$	V

Table 8. DC Electrical Specifications

Characteristic	Symbol	Min	Max	Units
Weak Internal Pull Up Device Current, tested at $V_{IL}$ Max. <sup>5</sup>	$I_{APU}$	-10	-130	$\mu A$
Input Capacitance <sup>6</sup> All input-only pins All input/output (three-state) pins	$C_{in}$	— —	7 7	pF
Load Capacitance Low drive strength High drive strength	$C_L$		25 50	pF
DC Injection Current <sup>3, 7, 8, 9</sup> $V_{NEGCLAMP} = V_{SS} - 0.3$ V, $V_{POSCLAMP} = V_{DD} + 0.3$ Single Pin Limit Total MCU Limit, Includes sum of all stressed pins	$I_{IC}$	-1.0 -10	1.0 10	mA

<sup>1</sup>  $I_{V_{DD}}$  and  $PV_{DD}$  should be at the same voltage.  $PV_{DD}$  should have a filtered input. Please see the PLL section of this specification for an example circuit. There are three  $PV_{DD}$  inputs, one for each PLL. A filter circuit should be used on each  $PV_{DD}$  input.

<sup>2</sup> Valid for all parts, EXCEPT the MCF54452YVR200.

<sup>3</sup> Valid just the MCF54452YVR200 part number.

<sup>4</sup> Worst-case tristate leakage current with only one I/O pin high. Since all I/Os share power when high, the leakage current is distributed among them. With all I/Os high, this spec reduces to  $\pm 2 \mu A$  min/max.

<sup>5</sup> Refer to the *MCF54455 Reference Manual* signals description chapter for pins having weak internal pull-up devices.

<sup>6</sup> This parameter is characterized before qualification rather than 100% tested.

<sup>7</sup> All functional non-supply pins are internally clamped to  $V_{SS}$  and their respective  $V_{DD}$ .

<sup>8</sup> Input must be current limited to the value specified. To determine the value of the required current-limiting resistor, calculate resistance values for positive and negative clamp voltages, then use the larger of the two values.

<sup>9</sup> Power supply must maintain regulation within operating  $V_{DD}$  range during instantaneous and operating maximum current conditions. If positive injection current ( $V_{in} > V_{DD}$ ) is greater than  $I_{DD}$ , the injection current may flow out of  $V_{DD}$  and could result in external power supply going out of regulation. Ensure the external  $V_{DD}$  load shunts current greater than the maximum injection current. This is the greatest risk when the MCU is not consuming power. Examples are: if no system clock is present, or if clock rate is very low which would reduce overall power consumption. Also, at power-up, the system clock is not present during the power-up sequence until the PLL has attained lock.

## 5.5 ClockTiming Specifications

The clock module configures the device for one of several clocking methods. Clocking modes include internal phase-locked loop (PLL) clocking with an external clock reference or an external crystal reference supported by an internal crystal amplifier. The PLL can also be disabled, and an external oscillator can directly clock the device.

The specifications in [Table 9](#) are for the CLKIN input pin (EXTAL input driven by an external clock reference). The duty cycle specification is based on an acceptable tolerance for the PLL, which yields 50% duty-cycle internal clocks to all on-chip peripherals. The MCF5445x devices use the input clock signal as its synchronous bus clock for PCI. A poor duty cycle on the input clock, may affect the overall timing margin to external devices. If negative edge logic is used to interface to PCI, providing a 50% duty-cycle input clock aids in simplifying overall system design.

Table 9. Input Clock Timing Requirements

Item	Specification	Min	Max	Unit
C1	Cycle time	15	40	ns
1 / C1	Frequency	25	66.66	MHz
C2	Rise time (20% of vdd to 80% of vdd)	-	2	ns
C3	Fall time (80% of vdd to 20% of vdd)	-	2	ns
C4	Duty cycle (at 50% of vdd)	40	60	%

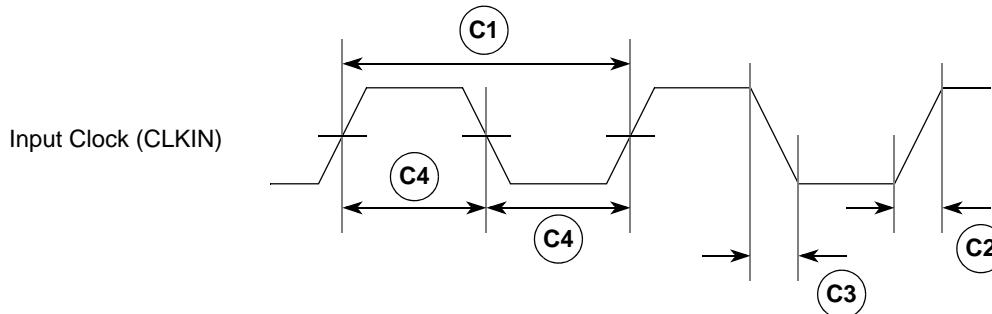

Figure 7. Input Clock Timing Diagram

Table 10. PLL Electrical Characteristics

Num	Characteristic	Symbol	Min. Value	Max. Value	Unit
1	PLL Reference Frequency Range Crystal reference External reference	$f_{ref\_crystal}$	16	40	MHz
		$f_{ref\_ext}$	16	66.66	MHz
2	Core/System Frequency	$f_{sys}$	512 Hz <sup>1</sup>	266.67 MHz	—
	Core/System Clock Period	$t_{sys}$	—	$1/f_{sys}$	ns
19	VCO Frequency ( $f_{vco} = f_{ref} \times PFDR$ )	$f_{vco}$	300	540	MHz
3	Crystal Start-up Time <sup>2, 3</sup>	$t_{cst}$	—	10	ms
4	EXTAL Input High Voltage Crystal Mode <sup>4</sup> All other modes (External, Limp)	$V_{IHEXT}$	$V_{XTAL} + 0.4$	—	V
		$V_{IHEXT}$	$E_{VDD}/2 + 0.4$	—	V
5	EXTAL Input Low Voltage Crystal Mode <sup>4</sup> All other modes (External, Limp)	$V_{ILEXT}$	—	$V_{XTAL} - 0.4$	V
		$V_{ILEXT}$	—	$E_{VDD}/2 - 0.4$	V
6	EXTAL Input Rise & Fall Time (20% to 80% $E_{VDD}$ ) (External, Limp)		1	2	ns
7	PLL Lock Time <sup>3, 5</sup>	$t_{pll}$	—	50000	CLKIN
8	Duty Cycle of reference <sup>3</sup> (External, Limp)	$t_{dc}$	40	60	%
9	XTAL Current	$I_{XTAL}$	1	3	mA
10	Total on-chip stray capacitance on XTAL	$C_{S\_XTAL}$	—	1.5	pF

**Table 10. PLL Electrical Characteristics (continued)**

Num	Characteristic	Symbol	Min. Value	Max. Value	Unit
11	Total on-chip stray capacitance on EXTAL	$C_{S\_EXTAL}$	—	1.5	pF
12	Crystal capacitive load	$C_L$	See crystal spec		
13	Discrete load capacitance for XTAL Discrete load capacitance for EXTAL	$C_{L\_XTAL}$ $C_{L\_EXTAL}$	—	$2 \times (C_L - C_{S\_XTAL} - C_{S\_EXTAL} - C_{S\_PCB})^6$	pF
14	Frequency un-LOCK Range	$f_{UL}$	-4.0	4.0	% $f_{sys}$
15	Frequency LOCK Range	$f_{LCK}$	-2.0	2.0	% $f_{sys}$
17	CLKOUT Period Jitter, <sup>3, 4, 7</sup> Measured at $f_{sys}$ Max Peak-to-peak Jitter (Clock edge to clock edge)	$C_{jitter}$	—	10	% FB_CLK

<sup>1</sup> The minimum system frequency is the minimum input clock divided by the maximum low-power divider (16 MHz ÷ 32,768). When the PLL is enabled, the minimum system frequency ( $f_{sys}$ ) is 150 MHz.

<sup>2</sup> This parameter is guaranteed by characterization before qualification rather than 100% tested. Applies to external clock reference only.

<sup>3</sup> Proper PC board layout procedures must be followed to achieve specifications.

<sup>4</sup> This parameter is guaranteed by design rather than 100% tested.

<sup>5</sup> This specification is the PLL lock time only and does not include oscillator start-up time.

<sup>6</sup>  $C_{S\_PCB}$  is the measured PCB stray capacitance on EXTAL and XTAL.

<sup>7</sup> Jitter is the average deviation from the programmed frequency measured over the specified interval at maximum  $f_{sys}$ . Measurements are made with the device powered by filtered supplies and clocked by a stable external clock signal. Noise injected into the PLL circuitry via PLL  $V_{DD}$ ,  $EV_{DD}$ , and  $V_{SS}$  and variation in crystal oscillator frequency increase the  $C_{jitter}$  percentage for a given interval.

## 5.6 Reset Timing Specifications

Table 11 lists specifications for the reset timing parameters shown in Figure 8.

**Table 11. Reset and Configuration Override Timing**

Num	Characteristic	Min	Max	Unit
R1 <sup>1</sup>	$\overline{RESET}$ valid to CLKIN (setup)	9	—	ns
R2	CLKIN to $\overline{RESET}$ invalid (hold)	1.5	—	ns
R3	$\overline{RESET}$ valid time <sup>2</sup>	5	—	CLKIN cycles
R4	CLKIN to $\overline{RSTOUT}$ valid	—	10	ns
R5	$\overline{RSTOUT}$ valid to Configuration Override inputs valid	0	—	ns
R6	Configuration Override inputs valid to $\overline{RSTOUT}$ invalid (setup)	20	—	CLKIN cycles
R7	Configuration Override inputs invalid after $\overline{RSTOUT}$ invalid (hold)	0	—	ns
R8	$\overline{RSTOUT}$ invalid to Configuration Override inputs High Impedance	—	1	CLKIN cycles

<sup>1</sup>  $\overline{RESET}$  and Configuration Override data lines are synchronized internally. Setup and hold times must be met only if recognition on a particular clock is required.

<sup>2</sup> During low power STOP, the synchronizers for the  $\overline{RESET}$  input are bypassed and  $\overline{RESET}$  is asserted asynchronously to the system. Thus,  $\overline{RESET}$  must be held a minimum of 100 ns.

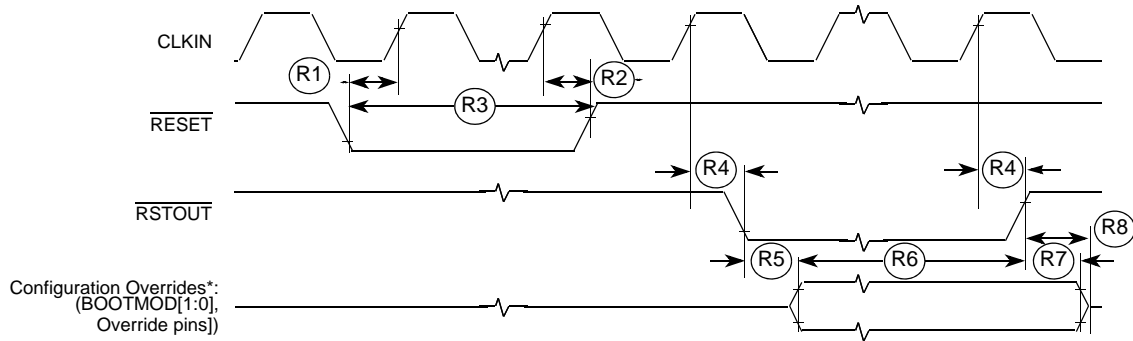
Figure 8.  $\overline{\text{RESET}}$  and Configuration Override Timing

## 5.7 FlexBus Timing Specifications

A multi-function external bus interface called FlexBus is provided with basic functionality to interface to slave-only devices up to a maximum bus frequency of 66MHz. It can be directly connected to asynchronous or synchronous devices such as external boot ROMs, flash memories, gate-array logic, or other simple target (slave) devices with little or no additional circuitry. For asynchronous devices, a simple chip-select based interface can be used.

All processor bus timings are synchronous; input setup/hold and output delay are given in respect to the rising edge of a reference clock, FB\_CLK. The FB\_CLK frequency may be the same as the internal system bus frequency or an integer divider of that frequency.

The following timing numbers indicate when data is latched or driven onto the external bus, relative to the Flexbus output clock (FB\_CLK). All other timing relationships can be derived from these values.

Table 12. FlexBus AC Timing Specifications

Num	Characteristic	Min	Max	Unit	Notes
	Frequency of Operation	25	66.66	MHz	
FB1	Clock Period	15	40	ns	
FB2	Output Valid	—	7.0	ns	1
FB3	Output Hold	1.0	—	ns	1
FB4	Input Setup	3.0	—	ns	2
FB5	Input Hold	0	—	ns	2

<sup>1</sup> Specification is valid for all FB\_AD[31:0], FB\_BS[3:0],  $\overline{\text{FB\_CS}}$ [3:0], FB\_OE, FB\_R/W, FB\_TBST, FB\_TSIZ[1:0], and  $\overline{\text{FB\_TS}}$ .

<sup>2</sup> Specification is valid for all FB\_AD[31:0] and  $\overline{\text{FB\_TA}}$ .

### NOTE

The processor drives the data lines during the first clock cycle of the transfer with the full 32-bit address. This may be ignored by standard connected devices using non-multiplexed address and data buses. However, some applications may find this feature beneficial.

The address and data busses are muxed between the FlexBus and PCI controller. At the end of the read and write bus cycles the address signals are indeterminate.

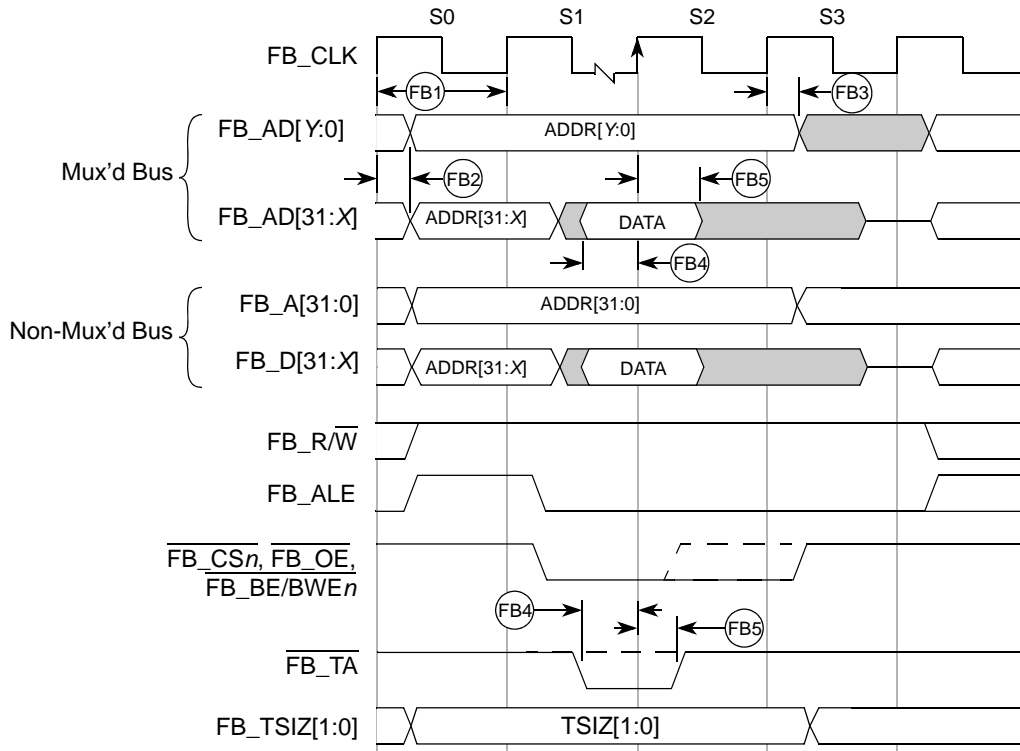

Figure 9. FlexBus Read Timing

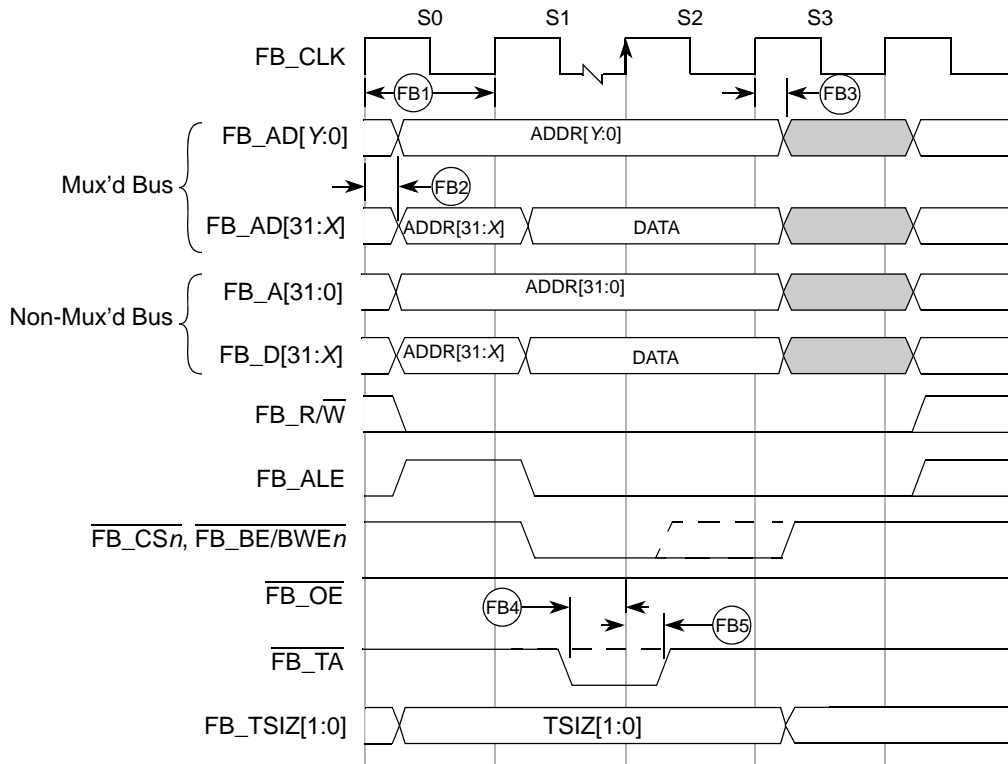

Figure 10. Flexbus Write Timing



## 5.8 SDRAM AC Timing Characteristics

The following timing numbers must be followed to properly latch or drive data onto the SDRAM memory bus. All timing numbers are relative to the four DQS byte lanes.

**Table 13. SDRAM Timing Specifications**

Num	Characteristic	Symbol	Min	Max	Unit	Notes
	Frequency of Operation		60	133.33	MHz	1
DD1	Clock Period	$t_{SDCK}$	7.5	16.67	ns	
DD2	Pulse Width High	$t_{SDCKH}$	0.45	0.55	$t_{SDCK}$	2
DD3	Pulse Width Low	$t_{SDCKL}$	0.45	0.55	$t_{SDCK}$	3
DD4	Address, $\overline{SD\_CKE}$ , $\overline{SD\_CAS}$ , $\overline{SD\_RAS}$ , $\overline{SD\_WE}$ , $\overline{SD\_CS}[1:0]$ — Output Valid	$t_{CMV}$	—	$(0.5 \times t_{SDCK}) + 1.0\text{ns}$	ns	3
DD5	Address, $\overline{SD\_CKE}$ , $\overline{SD\_CAS}$ , $\overline{SD\_RAS}$ , $\overline{SD\_WE}$ , $\overline{SD\_CS}[1:0]$ — Output Hold	$t_{CMH}$	2.0	—	ns	
DD6	Write Command to first DQS Latching Transition	$t_{DQSS}$	$(1.0 \times t_{SDCK}) - 0.6\text{ns}$	$(1.0 \times t_{SDCK}) + 0.6\text{ns}$	ns	
DD7	Data and Data Mask Output Setup (DQ-->DQS) Relative to DQS (DDR Write Mode)	$t_{QS}$	1.0	—	ns	4 5
DD8	Data and Data Mask Output Hold (DQS-->DQ) Relative to DQS (DDR Write Mode)	$t_{QH}$	1.0	—	ns	6
DD9	Input Data Skew Relative to DQS (Input Setup)	$t_{IS}$	—	1.0	ns	7
DD10	Input Data Hold Relative to DQS.	$t_{IH}$	$(0.25 \times t_{SDCK}) + 0.5\text{ns}$	—	ns	8

<sup>1</sup> The SDRAM interface operates at the same frequency as the internal system bus.

<sup>2</sup> Pulse width high plus pulse width low cannot exceed min and max clock period.

<sup>3</sup> Command output valid should be 1/2 the memory bus clock ( $t_{SDCK}$ ) plus some minor adjustments for process, temperature, and voltage variations.

<sup>4</sup> This specification relates to the required input setup time of DDR memories. The microprocessor's output setup should be larger than the input setup of the DDR memories. If it is not larger, then the input setup on the memory is in violation.  $SD\_D[31:24]$  is relative to  $SD\_DQS[3]$ ;  $SD\_D[23:16]$  is relative to  $SD\_DQS[2]$

<sup>5</sup> The first data beat is valid before the first rising edge of DQS and after the DQS write preamble. The remaining data beats are valid for each subsequent DQS edge.

<sup>6</sup> This specification relates to the required hold time of DDR memories.  $SD\_D[31:24]$  is relative to  $SD\_DQS[3]$ ;  $SD\_D[23:16]$  is relative to  $SD\_DQS[2]$

<sup>7</sup> Data input skew is derived from each DQS clock edge. It begins with a DQS transition and ends when the last data line becomes valid. This input skew must include DDR memory output skew and system level board skew (due to routing or other factors).

<sup>8</sup> Data input hold is derived from each DQS clock edge. It begins with a DQS transition and ends when the first data line becomes invalid.

**Electrical Characteristics**

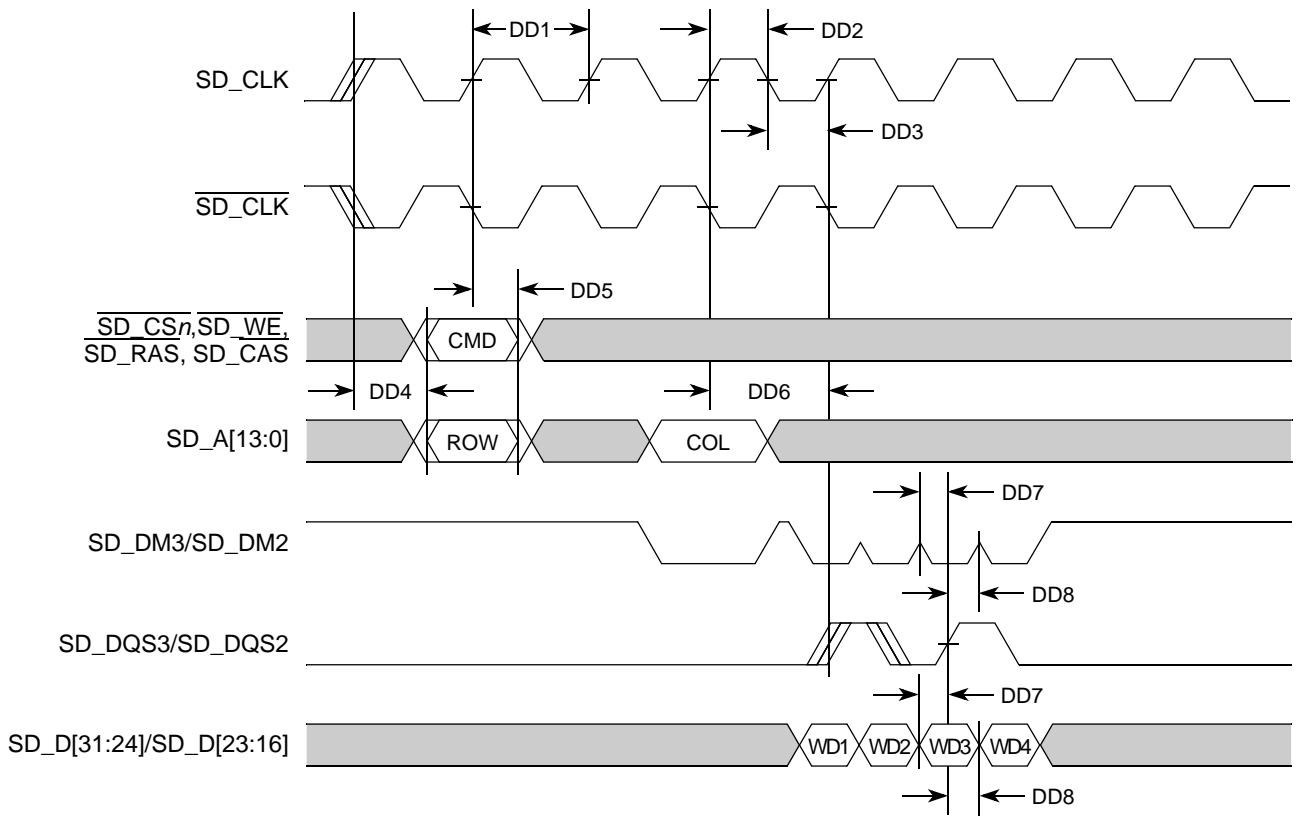

**Figure 11. DDR Write Timing**

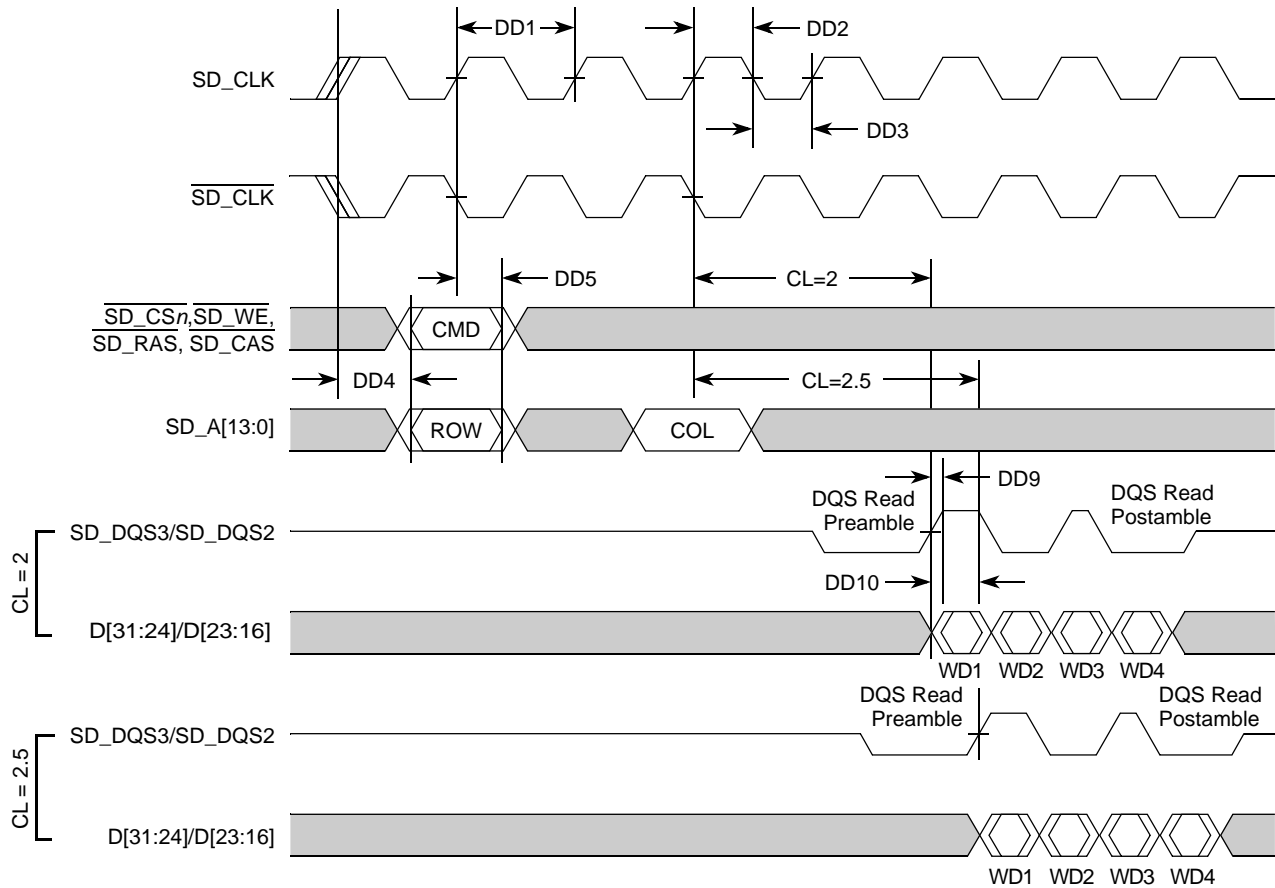

Figure 12. DDR Read Timing

## 5.9 PCI Bus Timing Specifications

The PCI bus on the device is PCI 2.2 compliant. The following timing numbers are mostly from the PCI 2.2 spec. Refer to the PCI 2.2 spec for a more detailed timing analysis.

Table 14. PCI Timing Specifications<sup>1,2</sup>

Num	Characteristic	33 MHz <sup>3</sup>		66 MHz <sup>3</sup>		Unit
		Min	Max	Min	Max	
	Frequency of Operation	—	33.33	33.33	66.66	MHz
P1	Clock Period	30	—	15	30	ns
P2	Bused PCI signals — input setup	7.0	—	3.0	—	ns
P3	PCI_GNT[3:0]/PCI_REQ[3:0] — input setup	10.0	—	5.0	—	ns
P4	All PCI signals — input hold	0	—	0	—	ns
P5	Bused PCI signals — output valid	—	11.0	—	6.0	ns

Table 14. PCI Timing Specifications<sup>1,2</sup> (continued)

Num	Characteristic	33 MHz <sup>3</sup>		66 MHz <sup>3</sup>		Unit
		Min	Max	Min	Max	
P6	PCI_REQ[3:0]/PCI_GNT[3:0] — output valid	—	12.0	—	6.0	ns
P7	All PCI signals — output hold	2.0	—	1.0	—	ns

<sup>1</sup> The PCI bus operates at the CLKIN frequency. All timings are relative to the input clock, CLKIN.

<sup>2</sup> All PCI signals are bused signals except for PCI\_GNT[3:0] and PCI\_REQ[3:0]. These signals are defined as point-to-point signals by the PCI Specification.

<sup>3</sup> The 66-MHz parameters are only guaranteed when the 66-MHz PCI pad slew rates are selected. Likewise, the 33-MHz parameters are only guaranteed when the 33-MHz PCI pad slew rates are selected.

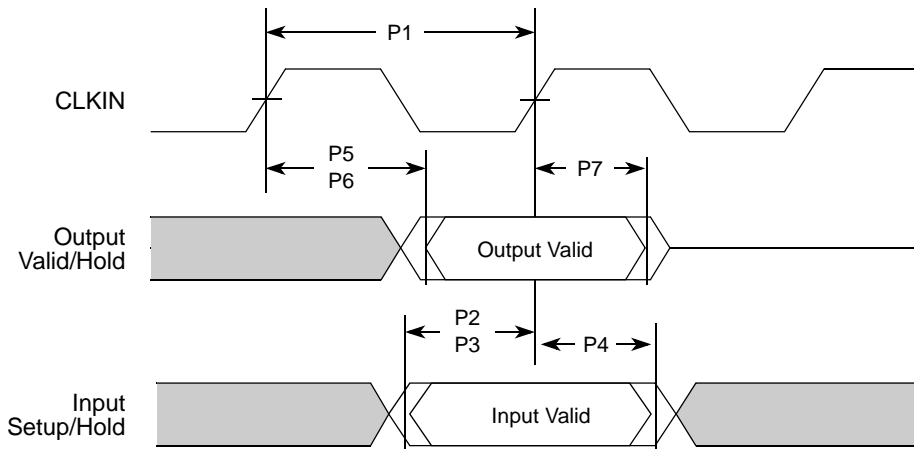

Figure 13. PCI Timing

### 5.9.1 Overshoot and Undershoot

Figure 14 shows the specification limits for overshoot and undershoot for PCI I/O. To guarantee long term reliability, the specification limits shown must be followed. Good transmission line design practices should be observed to guarantee the specification limits.

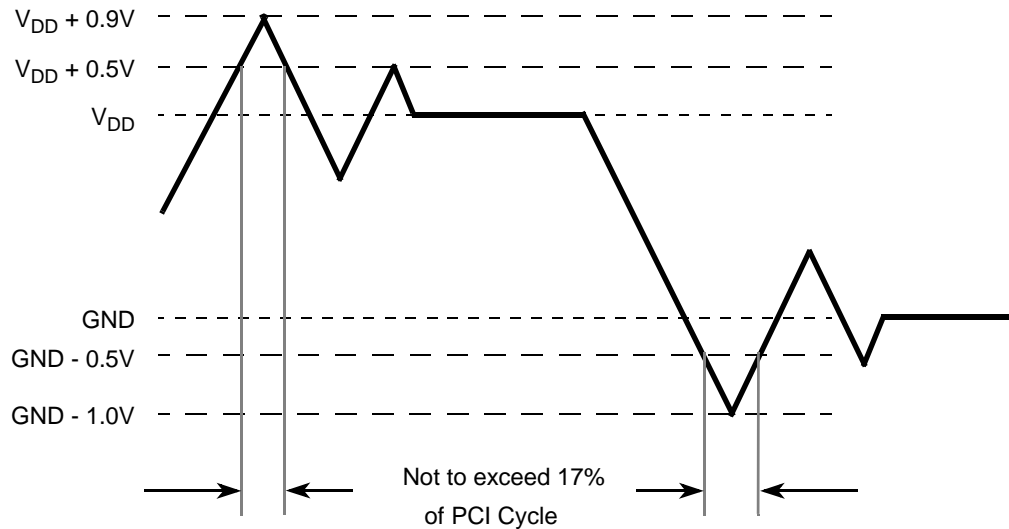

Figure 14. Overshoot and Undershoot Limits

## 5.10 ULPI Timing Specifications

The ULPI interface is fully compliant with the industry standard UTMI+ Low Pin Interface. Control and data timing requirements for the ULPI pins are given in Table 15. These timings apply to synchronous mode only. All timings are measured with respect to the clock as seen at the USB\_CLKIN pin on the MCF5445x. The ULPI PHY is the source of the 60MHz clock.

### NOTE

The USB controller requires a 60-MHz clock, even if using the on-chip FS/LS transceiver instead of the ULPI interface. In this case, the 60-MHz clock can be generated by the PLL or input on the USB\_CLKIN pin.

Table 15. ULPI Interface Timing

Num	Characteristic	Min	Nominal	Max	Units
	USB_CLKIN operating frequency	—	60	—	MHz
	USB_CLKIN duty cycle	—	50	—	%
U1	USB_CLKIN clock period	—	16.67	—	ns
U2	Input Setup (control and data)	5.0	—	—	ns
U3	Input Hold (control and data)	1.0	—	—	ns
U4	Output Valid (control and data)	—	—	9.5	ns
U5	Output Hold (control and data)	1.0	—	—	

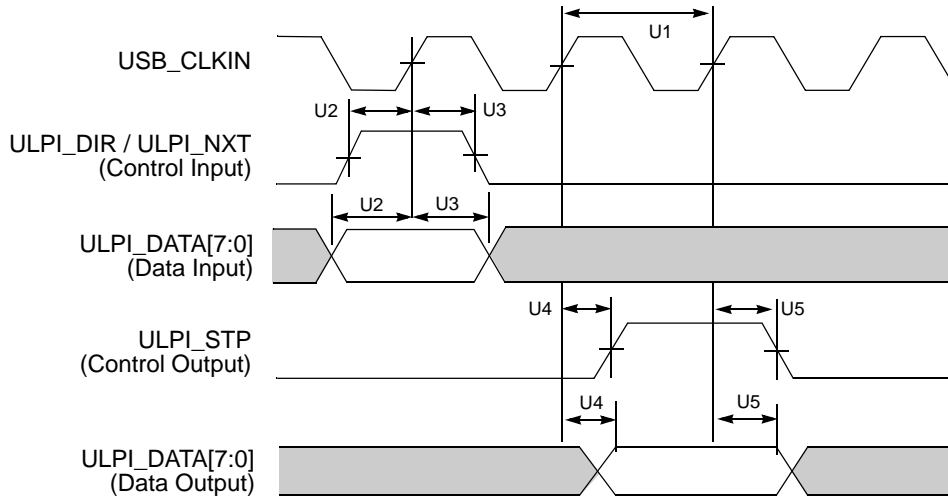

Figure 15. ULPI Timing Diagram

## 5.11 SSI Timing Specifications

This section provides the AC timings for the SSI in master (clocks driven) and slave modes (clocks input). All timings are given for non-inverted serial clock polarity (SSI\_TCR[TSCKP] = 0, SSI\_RCR[RSCKP] = 0) and a non-inverted frame sync (SSI\_TCR[TFSI] = 0, SSI\_RCR[RFSI] = 0). If the polarity of the clock and/or the frame sync have been inverted, all the timings remain valid by inverting the clock signal (SSI\_BCLK) and/or the frame sync (SSI\_FS) shown in the figures below.

Table 16. SSI Timing — Master Modes<sup>1</sup>

Num	Description	Symbol	Min	Max	Units	Notes
S1	SSI_MCLK cycle time	$t_{MCLK}$	$2 \times t_{SYS}$	—	ns	<sup>2</sup>
S2	SSI_MCLK pulse width high / low		45%	55%	$t_{MCLK}$	
S3	SSI_BCLK cycle time	$t_{BCLK}$	$8 \times t_{SYS}$	—	ns	<sup>3</sup>
S4	SSI_BCLK pulse width		45%	55%	$t_{BCLK}$	
S5	SSI_BCLK to SSI_FS output valid		—	15	ns	
S6	SSI_BCLK to SSI_FS output invalid		0	—	ns	
S7	SSI_BCLK to SSI_TXD valid		—	15	ns	
S8	SSI_BCLK to SSI_TXD invalid / high impedance		-2	—	ns	
S9	SSI_RXD / SSI_FS input setup before SSI_BCLK		10	—	ns	
S10	SSI_RXD / SSI_FS input hold after SSI_BCLK		0	—	ns	

<sup>1</sup> All timings specified with a capacitive load of 25pF.

<sup>2</sup> SSI\_MCLK can be generated from SSI\_CLKIN or a divided version of the internal system clock ( $f_{SYS}$ ).

<sup>3</sup> SSI\_BCLK can be derived from SSI\_CLKIN or a divided version of the internal system clock ( $f_{SYS}$ ).

Table 17. SSI Timing — Slave Modes<sup>1</sup>

Num	Description	Symbol	Min	Max	Units	Notes
S11	SSI_BCLK cycle time	$t_{BCLK}$	$8 \times t_{SYS}$	—	ns	
S12	SSI_BCLK pulse width high / low		45%	55%	$t_{BCLK}$	
S13	SSI_FS input setup before SSI_BCLK		10	—	ns	
S14	SSI_FS input hold after SSI_BCLK		2	—	ns	
S15	SSI_BCLK to SSI_TXD / SSI_FS output valid		—	15	ns	
S16	SSI_BCLK to SSI_TXD / SSI_FS output invalid / high impedance		0	—	ns	
S17	SSI_RXD setup before SSI_BCLK		10	—	ns	
S18	SSI_RXD hold after SSI_BCLK		2	—	ns	

<sup>1</sup> All timings specified with a capacitive load of 25pF.

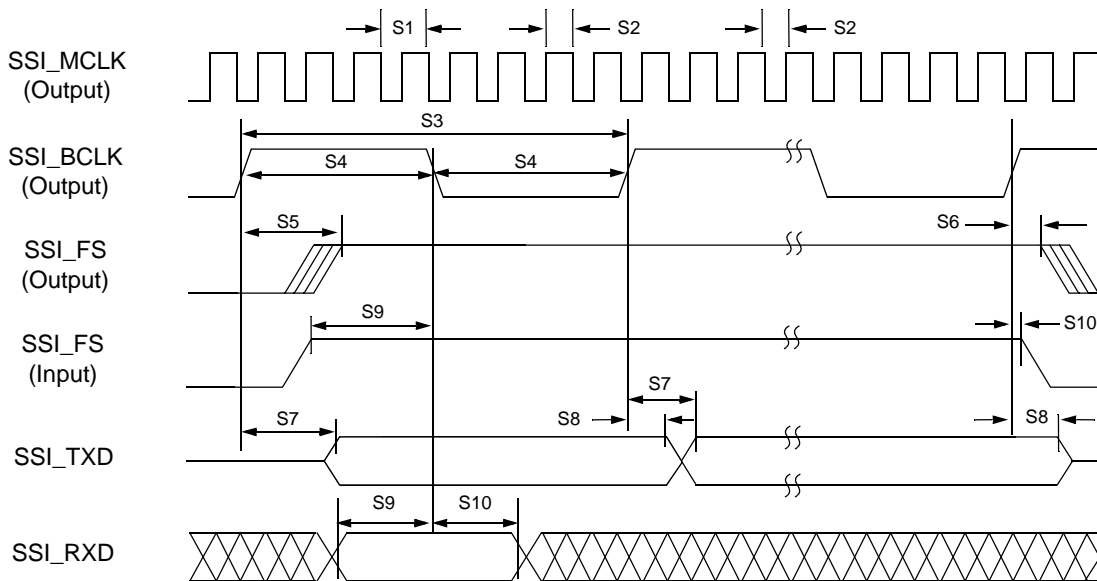

Figure 16. SSI Timing — Master Modes

## Electrical Characteristics

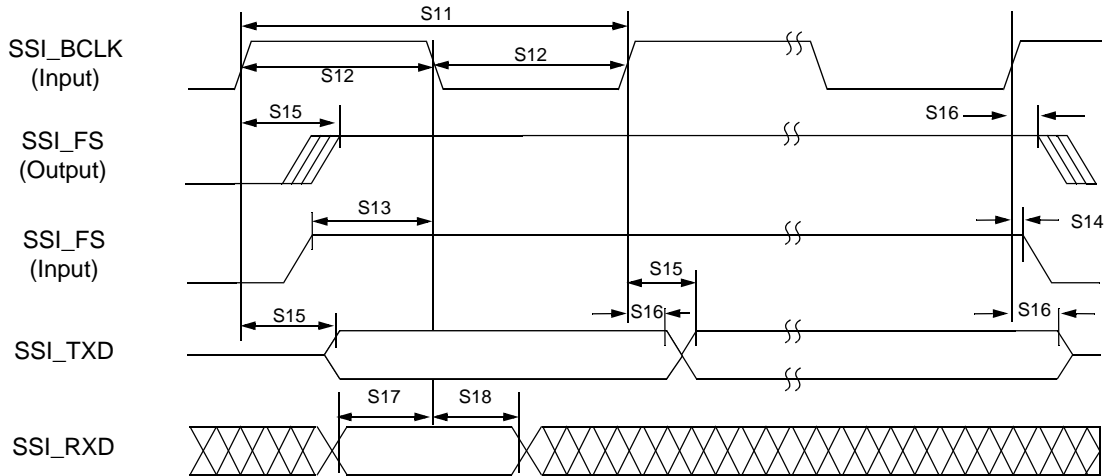

Figure 17. SSI Timing — Slave Modes

## 5.12 I<sup>2</sup>C Timing Specifications

Table 18 lists specifications for the I<sup>2</sup>C input timing parameters shown in Figure 18.

Table 18. I<sup>2</sup>C Input Timing Specifications between SCL and SDA

Num	Characteristic	Min	Max	Units
I1	Start condition hold time	2	—	t <sub>SYS</sub>
I2	Clock low period	8	—	t <sub>SYS</sub>
I3	I2C_SCL/I2C_SDA rise time (V <sub>IL</sub> = 0.5 V to V <sub>IH</sub> = 2.4 V)	—	1	ms
I4	Data hold time	0	—	ns
I5	I2C_SCL/I2C_SDA fall time (V <sub>IH</sub> = 2.4 V to V <sub>IL</sub> = 0.5 V)	—	1	ms
I6	Clock high time	4	—	t <sub>SYS</sub>
I7	Data setup time	0	—	ns
I8	Start condition setup time (for repeated start condition only)	2	—	t <sub>SYS</sub>
I9	Stop condition setup time	2	—	t <sub>SYS</sub>

Table 19 lists specifications for the I<sup>2</sup>C output timing parameters shown in Figure 18.

Table 19. I<sup>2</sup>C Output Timing Specifications between SCL and SDA

Num	Characteristic	Min	Max	Units
I1 <sup>1</sup>	Start condition hold time	6	—	t <sub>SYS</sub>
I2 <sup>1</sup>	Clock low period	10	—	t <sub>SYS</sub>
I3 <sup>2</sup>	I2C_SCL/I2C_SDA rise time (V <sub>IL</sub> = 0.5 V to V <sub>IH</sub> = 2.4 V)	—	—	μs
I4 <sup>1</sup>	Data hold time	7	—	t <sub>SYS</sub>
I5 <sup>3</sup>	I2C_SCL/I2C_SDA fall time (V <sub>IH</sub> = 2.4 V to V <sub>IL</sub> = 0.5 V)	—	3	ns



**Table 19. I<sup>2</sup>C Output Timing Specifications between SCL and SDA (continued)**

Num	Characteristic	Min	Max	Units
I6 <sup>1</sup>	Clock high time	10	—	t <sub>SYS</sub>
I7 <sup>1</sup>	Data setup time	2	—	t <sub>SYS</sub>
I8 <sup>1</sup>	Start condition setup time (for repeated start condition only)	20	—	t <sub>SYS</sub>
I9 <sup>1</sup>	Stop condition setup time	10	—	t <sub>SYS</sub>

<sup>1</sup> Output numbers depend on the value programmed into the IFDR; an IFDR programmed with the maximum frequency (IFDR = 0x20) results in minimum output timings as shown in Table 19. The I<sup>2</sup>C interface is designed to scale the actual data transition time to move it to the middle of the SCL low period. The actual position is affected by the prescale and division values programmed into the IFDR. However, the numbers given in Table 19 are minimum values.

<sup>2</sup> Because I2C\_SCL and I2C\_SDA are open-collector-type outputs, which the processor can only actively drive low, the time I2C\_SCL or I2C\_SDA take to reach a high level depends on external signal capacitance and pull-up resistor values.

<sup>3</sup> Specified at a nominal 50-pF load.

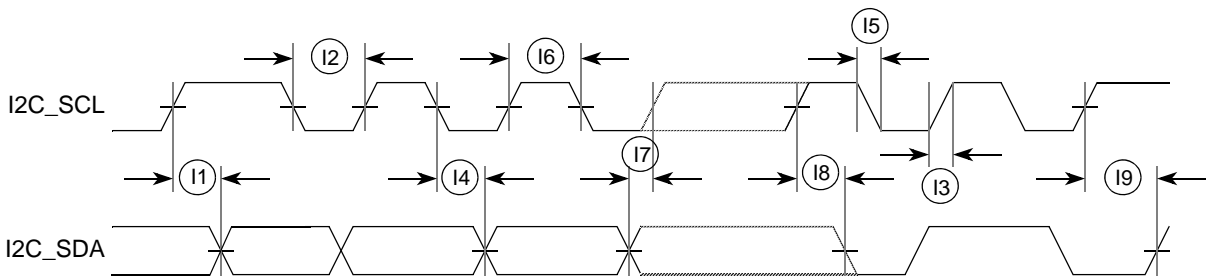
**Figure 18. I<sup>2</sup>C Input/Output Timings**

## 5.13 Fast Ethernet Timing Specifications

The following timing specs are defined at the chip I/O pin and must be translated appropriately to arrive at timing specs/constraints for the physical interface.

### 5.13.1 Receive Signal Timing Specifications

The following timing specs meet the requirements for MII and 7-Wire style interfaces for a range of transceiver devices.

**Table 20. Receive Signal Timing**

Num	Characteristic	MII Mode		RMII Mode		Unit
		Min	Max	Min	Max	
—	RXCLK frequency	—	25	—	50	MHz
E1	RXD[n:0], RXDV, RXER to RXCLK setup <sup>1</sup>	5	—	4	—	ns
E2	RXCLK to RXD[n:0], RXDV, RXER hold <sup>1</sup>	5	—	2	—	ns
E3	RXCLK pulse width high	35%	65%	35%	65%	RXCLK period
E4	RXCLK pulse width low	35%	65%	35%	65%	RXCLK period

<sup>1</sup> In MII mode, n = 3; In RMII mode, n = 1

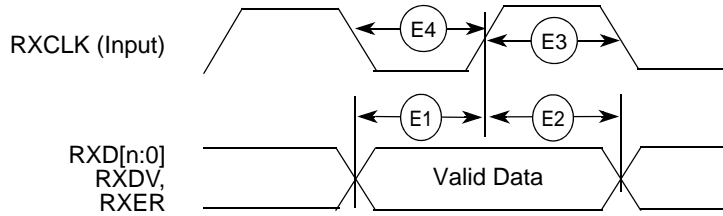

Figure 19. MII Receive Signal Timing Diagram

### 5.13.2 Transmit Signal Timing Specifications

Table 21. Transmit Signal Timing

Num	Characteristic	MII Mode		RMII Mode		Unit
		Min	Max	Min	Max	
—	TXCLK frequency	—	25	—	50	MHz
E5	TXCLK to TXD[n:0], TXEN, TXER invalid <sup>1</sup>	5	—	5	—	ns
E6	TXCLK to TXD[n:0], TXEN, TXER valid <sup>1</sup>	—	25	—	14	ns
E7	TXCLK pulse width high	35%	65%	35%	65%	t <sub>TXCLK</sub>
E8	TXCLK pulse width low	35%	65%	35%	65%	t <sub>TXCLK</sub>

<sup>1</sup> In MII mode, n = 3; In RMII mode, n = 1

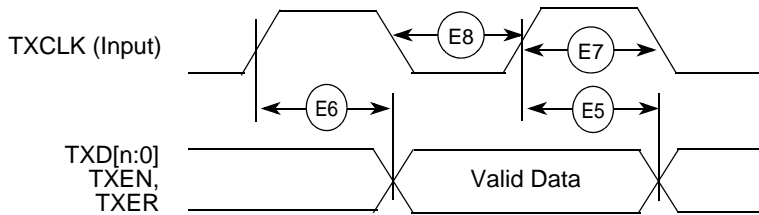

Figure 20. MII Transmit Signal Timing Diagram

### 5.13.3 Asynchronous Input Signal Timing Specifications

Table 22. MII Transmit Signal Timing

Num	Characteristic	Min	Max	Unit
E9	CRS, COL minimum pulse width	1.5	—	TXCLK period

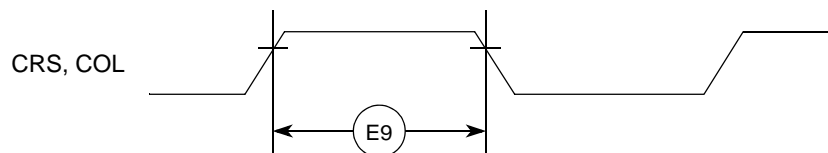

Figure 21. MII Async Inputs Timing Diagram

### 5.13.4 MII Serial Management Timing Specifications

Table 23. MII Serial Management Channel Signal Timing

Num	Characteristic	Symbol	Min	Max	Unit
E10	MDC cycle time	$t_{MDC}$	400	—	ns
E11	MDC pulse width		40	60	% $t_{MDC}$
E12	MDC to MDIO output valid		—	375	ns
E13	MDC to MDIO output invalid		25	—	ns
E14	MDIO input to MDC setup		10	—	ns
E15	MDIO input to MDC hold		0	—	ns

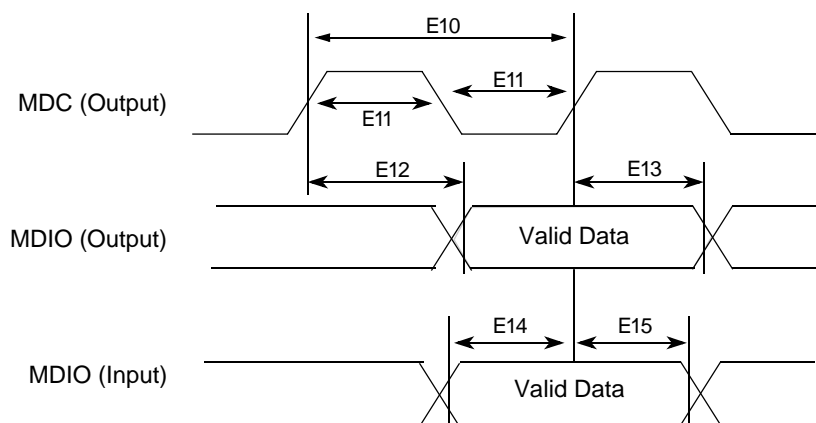

Figure 22. MII Serial Management Channel Timing Diagram

### 5.14 32-Bit Timer Module Timing Specifications

Table 24 lists timer module AC timings.

Table 24. Timer Module AC Timing Specifications

Name	Characteristic	Min	Max	Unit
T1	$DTnIN$ cycle time ( $n = 0:3$ )	3	—	$t_{sys}/2$
T2	$DTnIN$ pulse width ( $n = 0:3$ )	1	—	$t_{sys}/2$

## 5.15 ATA Interface Timing Specifications

The ATA controller is compatible with the ATA/ATAPI-6 industry standard. Refer to the *ATA/ATAPI-6 Specification* and the ATA controller chapter of the *MCF54455 Reference Manual* for timing diagrams of the various modes of operation.

The timings of the various ATA data transfer modes are determined by a set of timing equations described in the ATA section of the *MCF54455 Reference Manual*. These timing equations must be fulfilled for the ATA host to meet timing. [Table 25](#) provides implementation specific timing parameters necessary to complete the timing equations.

**Table 25. ATA Interface Timing Specifications<sup>1,2</sup>**

Name	Characteristic	Symbol	Min	Max	Unit	Notes
A1	Setup time — ATA_IORDY to SYSCLK falling	$t_{SUI}$	4.0	—	ns	
A2	Hold time — ATA_IORDY from SYSCLK falling	$t_{HI}$	3.0	—	ns	
A3	Setup time — ATA_DATA[15:0] to SYSCLK rising	$t_{SU}$	4.0	—	ns	
A4	Propagation delay — SYSCLK rising to all outputs	$t_{CO}$	—	7.0	ns	3
A5	Output skew	$t_{SKEW1}$	—	1.5	ns	3
A6	Setup time — ATA_DATA[15:0] valid to ATA_IORDY	$t_{I\_DS}$	2.0	—	ns	4
A7	Hold time — ATA_IORDY to ATA_DATA[15:0] invalid	$t_{I\_DH}$	3.5	—	ns	4

<sup>1</sup> These parameters are guaranteed by design and not testable.

<sup>2</sup> All timings specified with a capacitive load of 40pF.

<sup>3</sup> Applies to ATA\_CS[1:0], ATA\_DA[2:0], ATA\_DIOR, ATA\_DIOW, ATA\_DMACK, ATA\_DATA[15:0]

<sup>4</sup> Applies to Ultra DMA data-in burst only

## 5.16 DSPI Timing Specifications

The DMA Serial Peripheral Interface (DSPI) provides a synchronous serial bus with master and slave operations. Many of the transfer attributes are programmable. [Table 26](#) provides DSPI timing characteristics for classic SPI timing modes. Refer to the DSPI chapter of the *MCF54455 Reference Manual* for information on the modified transfer formats used for communicating with slower peripheral devices.

**Table 26. DSPI Module AC Timing Specifications<sup>1</sup>**

Name	Characteristic	Symbol	Min	Max	Unit	Notes
DS1	DSPI_SCK Cycle Time	$t_{SCK}$	$4 \times t_{SYS}$	—	ns	2
DS2	DSPI_SCK Duty Cycle	—	$(t_{sck} \div 2) - 2.0$	$(t_{sck} \div 2) + 2.0$	ns	3
<b>Master Mode</b>						
DS3	DSPI_PCS <sub>n</sub> to DSPI_SCK delay	$t_{CSC}$	$(2 \times t_{SYS}) - 1.5$	—	ns	4
DS4	DSPI_SCK to DSPI_PCS <sub>n</sub> delay	$t_{ASC}$	$(2 \times t_{SYS}) - 3.0$	—	ns	5
DS5	DSPI_SCK to DSPI_SOUT valid	—	—	5	ns	
DS6	DSPI_SCK to DSPI_SOUT invalid	—	-5	—	ns	
DS7	DSPI_SIN to DSPI_SCK input setup	—	9	—	ns	
DS8	DSPI_SCK to DSPI_SIN input hold	—	0	—	ns	
<b>Slave Mode</b>						
DS9	DSPI_SCK to DSPI_SOUT valid	—	—	10	ns	

Table 26. DSPI Module AC Timing Specifications<sup>1</sup> (continued)

Name	Characteristic	Symbol	Min	Max	Unit	Notes
DS10	DSPI_SCK to DSPI_SOUT invalid	—	0	—	ns	
DS11	DSPI_SIN to DSPI_SCK input setup	—	2	—	ns	
DS12	DSPI_SCK to DSPI_SIN input hold	—	7	—	ns	
DS13	DSPI_SS active to DSPI_SOUT driven	—	—	10	ns	
DS14	DSPI_SS inactive to DSPI_SOUT not driven	—	—	10	ns	

<sup>1</sup> Timings shown are for DMCR[MTFE] = 0 (classic SPI) and DCTAR<sub>n</sub>[CPHA] = 0. Data is sampled on the DSPI\_SIN pin on the odd-numbered DSPI\_SCK edges and driven on the DSPI\_SOUT pin on even-numbered DSPI edges.

<sup>2</sup> When in master mode, the baud rate is programmable in DCTAR<sub>n</sub>[DBR], DCTAR<sub>n</sub>[PBR], and DCTAR<sub>n</sub>[BR].

<sup>3</sup> This specification assumes a 50/50 duty cycle setting. The duty cycle is programmable in DCTAR<sub>n</sub>[DBR], DCTAR<sub>n</sub>[CPHA], and DCTAR<sub>n</sub>[PBR].

<sup>4</sup> The DSPI\_PCS<sub>n</sub> to DSPI\_SCK delay is programmable in DCTAR<sub>n</sub>[PCSSCK] and DCTAR<sub>n</sub>[CSSCK].

<sup>5</sup> The DSPI\_SCK to DSPI\_PCS<sub>n</sub> delay is programmable in DCTAR<sub>n</sub>[PASC] and DCTAR<sub>n</sub>[ASC].

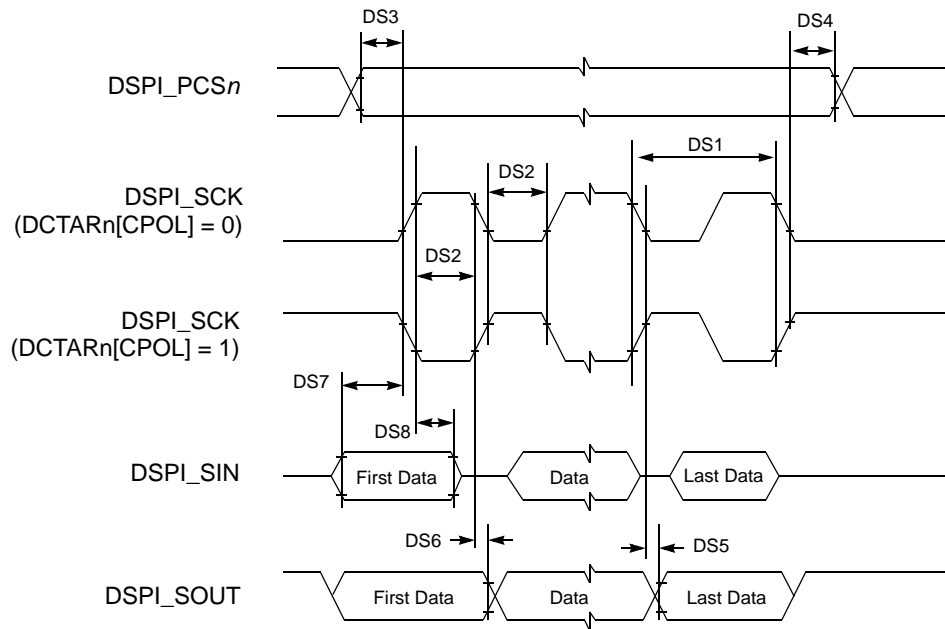

Figure 23. DSPI Classic SPI Timing — Master Mode

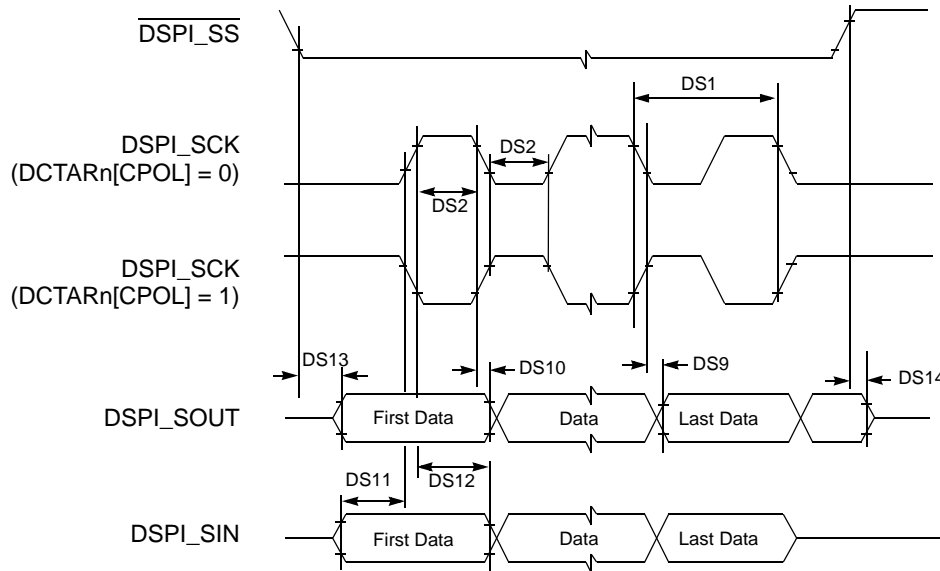

Figure 24. DSPI Classic SPI Timing — Slave Mode

### 5.17 SBF Timing Specifications

The Serial Boot Facility (SBF) provides a means to read configuration information and system boot code from a broad array of SPI-compatible EEPROMs, flashes, FRAMs, nVSRAMs, etc. Table 27 provides the AC timing specifications for the SBF.

Table 27. SBF AC Timing Specifications

Name	Characteristic	Symbol	Min	Max	Unit	Notes
SB1	SBF_CK Cycle Time	$t_{SBFCK}$	40	—	ns	1
SB2	SBF_CK High/Low Time	—	30%	—	$t_{SBFCK}$	
SB3	$\overline{SBF\_CS}$ to SBF_CK delay	—	$t_{SBFCK} - 2.0$	—	ns	
SB4	SBF_CK to $\overline{SBF\_CS}$ delay	—	$t_{SBFCK} - 2.0$	—	ns	
SB5	SBF_CK to SBF_DO valid	—	-5	—	ns	
SB6	SBF_CK to SBF_DO invalid	—	5	—	ns	
SB7	SBF_DI to SBF_SCK input setup	—	10	—	ns	
SB8	SBF_CK to SBF_DI input hold	—	0	—	ns	

<sup>1</sup> At reset, the SBF\_CK cycle time is  $t_{REF} \times 67$ . The first byte of data read from the serial memory contains a divider value that is used to set the SBF\_CK cycle time for the duration of the serial boot process.

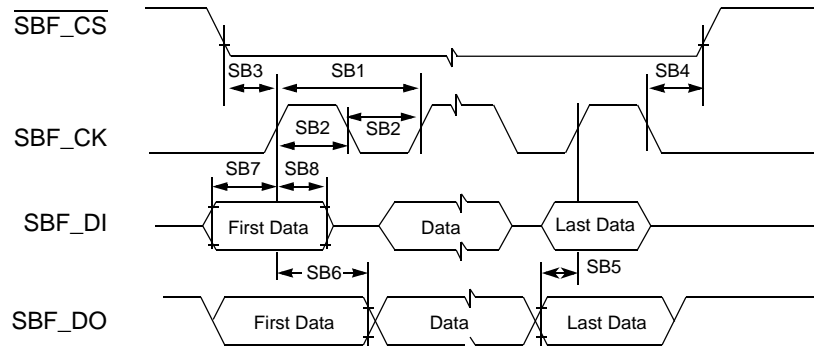

Figure 25. SBF Timing

## 5.18 General Purpose I/O Timing Specifications

Table 28. GPIO Timing<sup>1</sup>

Num	Characteristic	Min	Max	Unit
G1	FB_CLK High to GPIO Output Valid	—	9	ns
G2	FB_CLK High to GPIO Output Invalid	1.5	—	ns
G3	GPIO Input Valid to FB_CLK High	9	—	ns
G4	FB_CLK High to GPIO Input Invalid	1.5	—	ns

<sup>1</sup> These general purpose specifications apply to the following signals: IRQ<sub>n</sub>, all UART signals, all timer signals, DACK<sub>n</sub> and DREQ<sub>n</sub>, and all signals configured as GPIO.

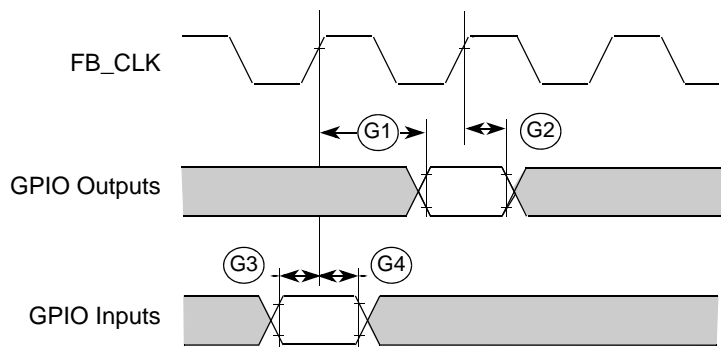

Figure 26. GPIO Timing

## 5.19 JTAG and Boundary Scan Timing

Table 29. JTAG and Boundary Scan Timing

Num	Characteristics <sup>1</sup>	Min	Max	Unit
J1	TCLK Frequency of Operation	DC	20	MHz
J2	TCLK Cycle Period	50	—	ns
J3	TCLK Clock Pulse Width	20	30	ns
J4	TCLK Rise and Fall Times	—	3	ns
J5	Boundary Scan Input Data Setup Time to TCLK Rise	5	—	ns
J6	Boundary Scan Input Data Hold Time after TCLK Rise	20	—	ns
J7	TCLK Low to Boundary Scan Output Data Valid	—	33	ns
J8	TCLK Low to Boundary Scan Output High Z	—	33	ns
J9	TMS, TDI Input Data Setup Time to TCLK Rise	4	—	ns
J10	TMS, TDI Input Data Hold Time after TCLK Rise	10	—	ns
J11	TCLK Low to TDO Data Valid	—	11	ns
J12	TCLK Low to TDO High Z	—	11	ns
J13	$\overline{\text{TRST}}$ Assert Time	50	—	ns
J14	$\overline{\text{TRST}}$ Setup Time (Negation) to TCLK High	10	—	ns

<sup>1</sup> JTAG\_EN is expected to be a static signal. Hence, specific timing is not associated with it.

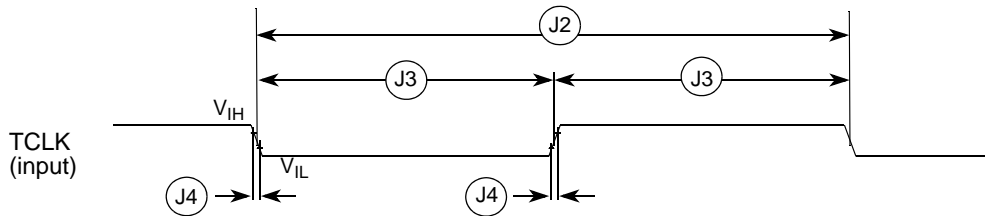

Figure 27. Test Clock Input Timing



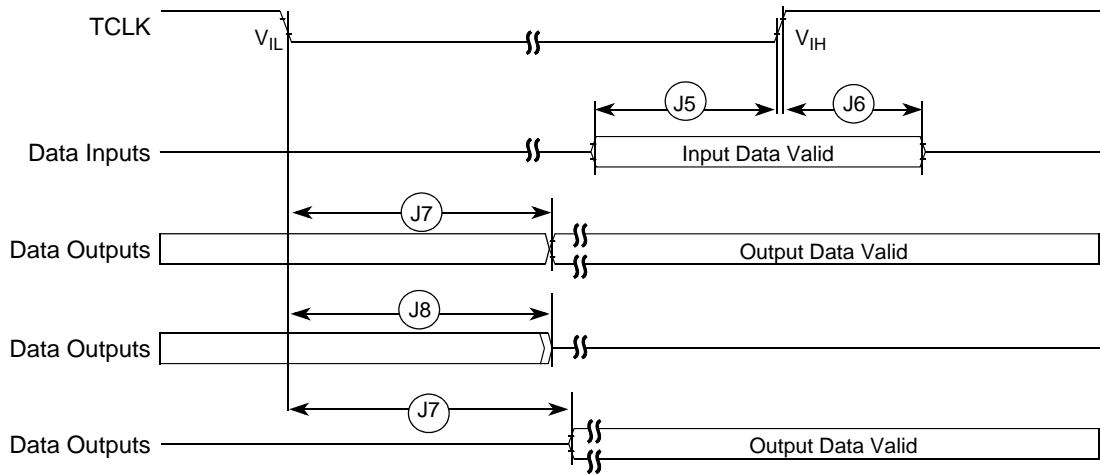

Figure 28. Boundary Scan (JTAG) Timing

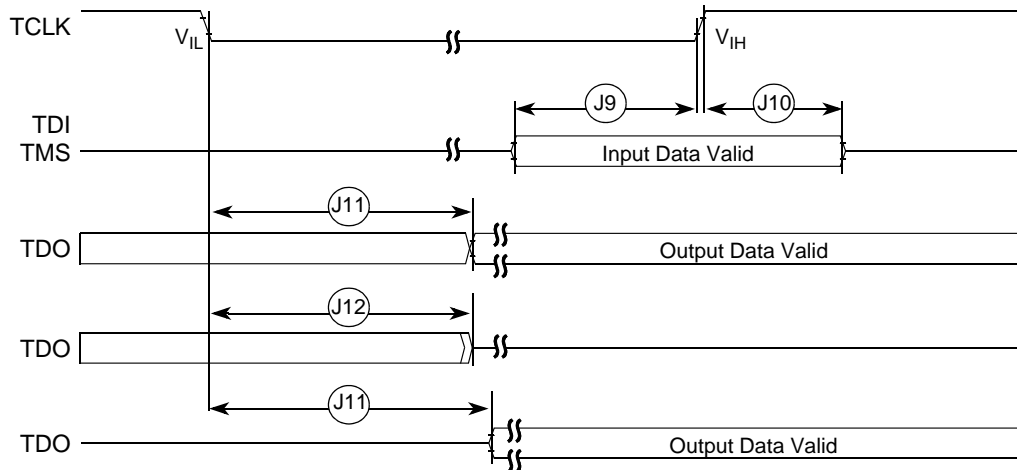

Figure 29. Test Access Port Timing

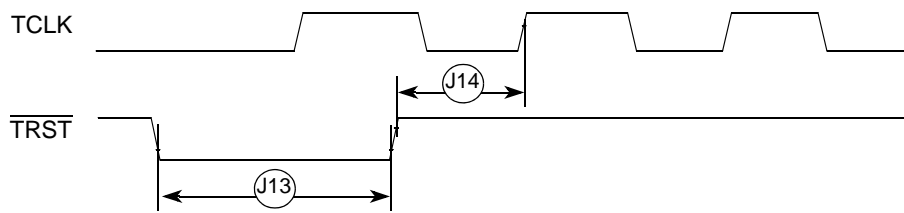

Figure 30.  $\overline{\text{TRST}}$  Timing

## 5.20 Debug AC Timing Specifications

Table 30 lists specifications for the debug AC timing parameters shown in Figure 31 and Table 32.

**Table 30. Debug AC Timing Specification**

Num	Characteristic	Min	Max	Units
D0	PSTCLK cycle time	1	1	$t_{sys}$
D1	PSTCLK rising to PSTDDATA valid	—	3.0	ns
D2	PSTCLK rising to PSTDDATA invalid	1.5	—	ns
D3	DSI-to-DSCLK setup	1	—	PSTCLK
D4 <sup>1</sup>	DSCLK-to-DSO hold	4	—	PSTCLK
D5	DSCLK cycle time	5	—	PSTCLK
D6	BKPT assertion time	1	—	PSTCLK

<sup>1</sup> DSCLK and DSI are synchronized internally. D4 is measured from the synchronized DSCLK input relative to the rising edge of PSTCLK.

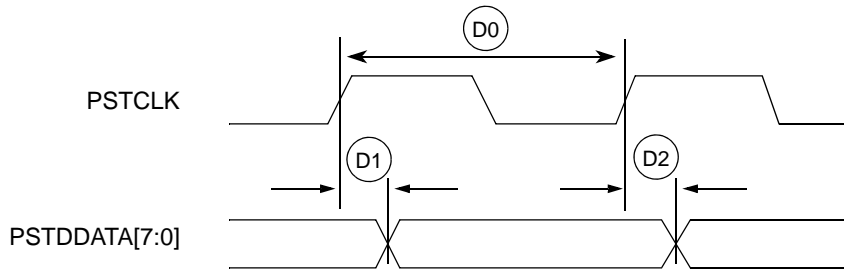

**Figure 31. Real-Time Trace AC Timing**

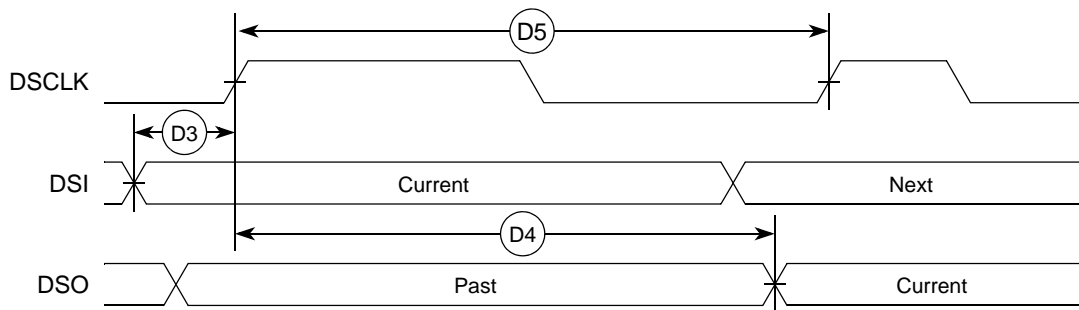

**Figure 32. BDM Serial Port AC Timing**

## 6 Power Consumption

All power consumption data is lab data measured on an M54455EVB running the NXP Linux BSP.

**Table 31. MCF4455 Application Power Consumption<sup>1</sup>**

Core Freq.		Idle	MP3 Playback	TFTP Download	USB HS File Copy	Units
266 MHz	$IV_{DD}$	215.6	288.8	274.4	263.7	mA
	$EV_{DD}$	27.6	33.6	32.6	32.4	
	$SDV_{DD}$	142.9	158.2	161.1	158.0	
	<b>Total Power</b>	<b>672</b>	<b>829</b>	<b>809</b>	<b>787</b>	<b>mW</b>
200 MHz	$IV_{DD}$	163.8	228.0	213.8	207.9	mA
	$EV_{DD}$	29.9	34.7	34.3	33.8	
	$SDV_{DD}$	142.2	158.5	160.0	153.4	
	<b>Total Power</b>	<b>601</b>	<b>742</b>	<b>722</b>	<b>699</b>	<b>mW</b>

<sup>1</sup> All voltage rails at nominal values:  $IV_{DD} = 1.5$  V,  $EV_{DD} = 3.3$  V, and  $SDV_{DD} = 1.8$  V.

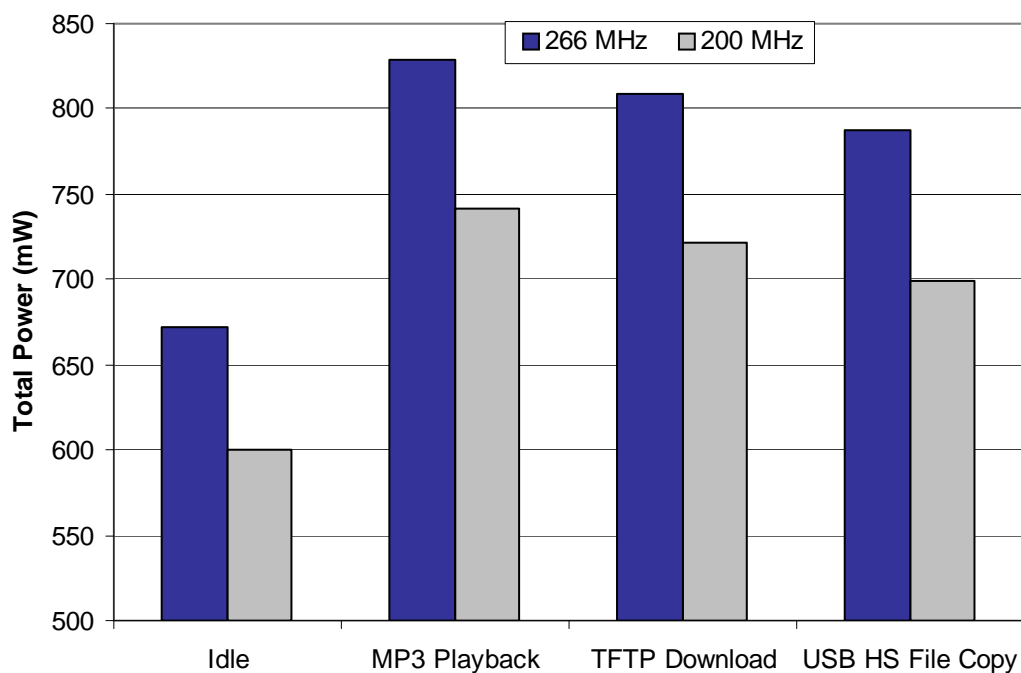

**Figure 33. Power Consumption in Various Applications**

## Power Consumption

All current consumption data is lab data measured on a single device using an evaluation board. Table 32 shows the typical power consumption in low-power modes. These current measurements are taken after executing a STOP instruction.

**Table 32. Current Consumption in Low-Power Modes<sup>1,2</sup>**

Mode	Voltage Supply	System Frequency				
		166 (Typ) <sup>3</sup>	200 (Typ) <sup>3</sup>	233 (Typ) <sup>3</sup>	266 (Typ) <sup>3</sup>	266 (Peak) <sup>4</sup>
RUN	$I_{V_{DD}}$ (mA)	93.4	110.9	128.2	145.4	202.1
	Power (mW)	140.1	166.3	192.4	218.1	303.2
WAIT/DOZE	$I_{V_{DD}}$ (mA)	28.0	32.7	37.5	41.1	100.2
	Power (mW)	42.0	49.1	56.2	61.7	150.3
STOP 0	$I_{V_{DD}}$ (mA)	17.1	19.8	22.5	25.2	25.2
	Power (mW)	25.7	29.7	33.7	37.8	37.8
STOP 1	$I_{V_{DD}}$ (mA)	17.9	19.8	22.4	25.1	25.1
	Power (mW)	26.8	29.6	33.6	37.6	37.6
STOP 2	$I_{V_{DD}}$ (mA)	5.7	5.7	5.7	5.7	5.7
	Power (mW)	8.6	8.6	8.6	8.6	8.6
STOP 3	$I_{V_{DD}}$ (mA)	1.8	1.8	1.8	1.8	1.8
	Power (mW)	2.6	2.6	2.6	2.6	2.6

<sup>1</sup> All values are measured on an M54455EVB with 1.5V  $I_{V_{DD}}$  power supply. Tests performed at room temperature.

<sup>2</sup> Refer to the Power Management chapter in the *MCF54455 Reference Manual* for more information on low-power modes.

<sup>3</sup> All peripheral clocks are off except UART0, INTC0, IACK, edge port, reset controller, CCM, PLL, and FlexBus prior to entering low-power mode.

<sup>4</sup> All peripheral clocks on prior to entering low-power mode.

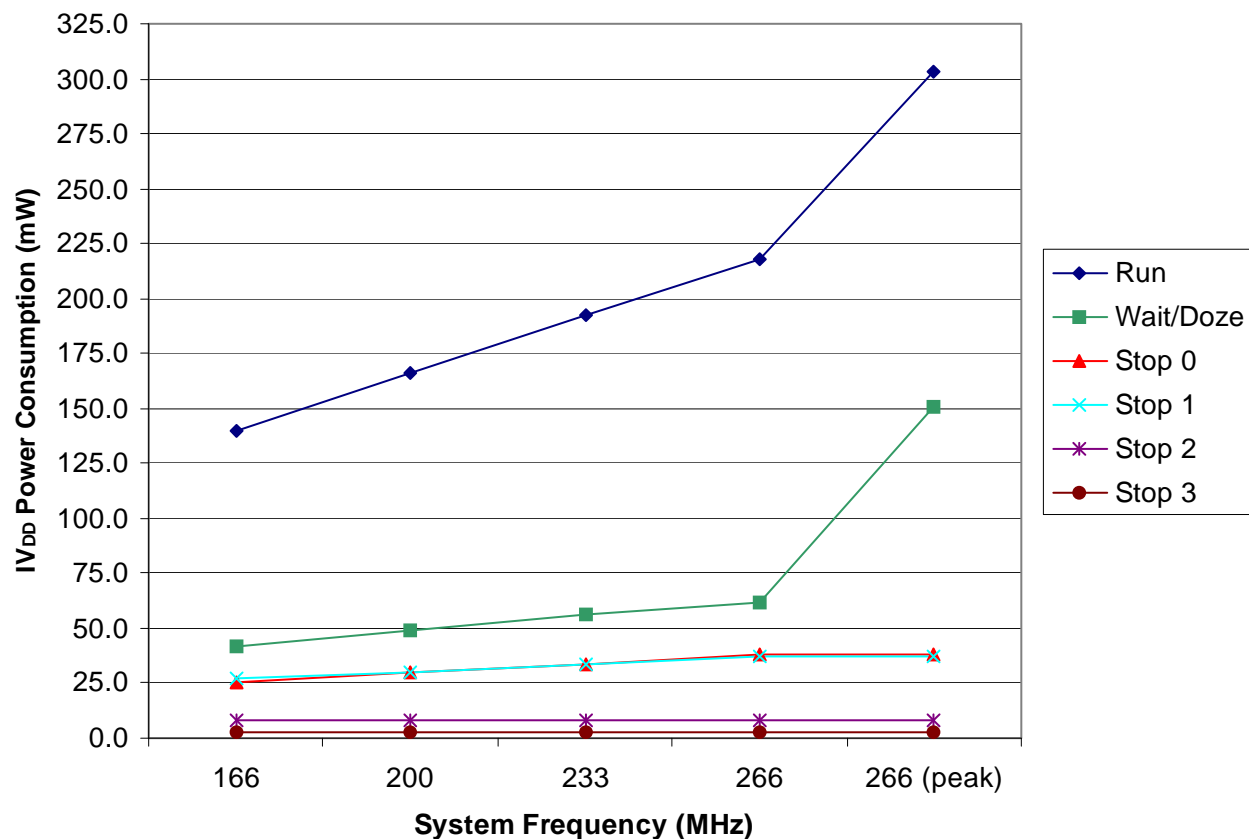
Figure 34. IV<sub>DD</sub> Power Consumption in Low-Power Modes

## 7 Package Information

The latest package outline drawings are available on the product summary pages on <http://www.nxp.com/coldfire>. Table 33 lists the case outline numbers per device. Use these numbers in the web page's keyword search engine to find the latest package outline drawings.

Table 33. Package Information

Device	Package Type	Case Outline Numbers
MCF54450	256 MAPBGA	98ARH98219A
MCF54451		
MCF54452	360 H PWR TEPBGA	98ASA01712D
MCF54453		
MCF54454		
MCF54455		

## 8 Product Documentation

Documentation is available from a local NXP distributor, an NXP sales office, the NXP Literature Distribution Center, or through the NXP world-wide web address at <http://www.nxp.com/coldfire>.

## 9 Revision History

Table 34 summarizes revisions to this document.

**Table 34. Revision History**

Rev. No.	Date	Summary of Changes
0	Sept 17, 2007	Initial public release.
1	Feb 15, 2008	Corrected VSS pin locations in MCF5445x signal information and muxing table for the 360 TEPBGA package: changed "...M9, M16, M17..." to "...M9–M14, M16..." Updated FlexBus read and write timing diagrams and added two notes before them. Change FB_A[23:0] to FB_A[31:0] in FlexBus read and write timing diagrams. Added power consumption section.
2	May 1, 2008	In Family Configurations table, added PCI as feature on 256-pin devices. On these devices the PCI_AD bus is limited to 24-bits. In Absolute Maximum Ratings table, changed RTCV <sub>DD</sub> specification from "-0.3 to +4.0" to "-0.5 to +2.0". In DC Electrical Specifications table: <ul style="list-style-type: none"> <li>• Changed RTCV<sub>DD</sub> specification from 3.0–3.6 to 1.35–1.65.</li> <li>• Changed High Impedance (Off-State) Leakage Current (I<sub>OZ</sub>) specification from ±1 to ±10μA, and added footnote to this spec: "Worst-case tristate leakage current with only one I/O pin high. Since all I/Os share power when high, the leakage current is distributed among them. With all I/Os high, this spec reduces to ±2 μA min/max."</li> </ul>
3	Dec 1, 2008	Changed "360PBGA" heading to "360 TEPBGA" in Table 6. Changed the following specs in Table 13: <ul style="list-style-type: none"> <li>• Minimum frequency of operation from — to 60MHz.</li> <li>• Maximum clock period from — to 16.67 ns.</li> </ul>
4	Apr 12, 2009	Rescinded previous errata, the 256-pin devices do not contain the PCI bus controller: <ul style="list-style-type: none"> <li>• In Table 4, in PCI_AD<sub>n</sub> signal section, added a separate row for each package, with PCI_AD<sub>n</sub> signals shown as — for 256-pin devices.</li> <li>• In Figure 5, changed the PCI_AD<sub>n</sub> pins to their alternative function, FB_An.</li> </ul>
5	Apr 27, 2009	In Table 2 changed MCF54450VM180 to MCF54450CVM180 and changed its temperature entry from "0° to +70° C" to "-40° to +85° C".
6	Oct 15, 2009	In Table 8 changed Input Leakage Current (I <sub>in</sub> ) from ±1.0 to ±2.5μA.
7	Oct 18, 2011	In Table 2, added MCF54452YVR200 part number, with temperature range from -40° to +105° C. In Table 8, added Input Leakage Current (I <sub>in</sub> ) values for MCF54452YVR200 part number.
8	Jan 18, 2012	In Table 4, added pin N7 in the VSS pin list for the 360 TEPBGA.
9	April 13, 2021	<ul style="list-style-type: none"> <li>• Updated instances of "Freescale" to "NXP" throughout the document.</li> <li>• Updated links referring to freescale.com to nxp.com.</li> <li>• In Table 2, updated the part numbers for MCF54452, MCF54453, MCF54454, and MCF54455 families.</li> <li>• In Table 33, updated package type from "360 TEPBGA" to "360 H PWR TEPBGA".</li> <li>• In Table 33, updated the case outline number from "98ARE10605D" to "98ASA01712D".</li> </ul>

## **How To Reach Us**

### **Home Page:**

[nxp.com](http://nxp.com)

### **Web Support:**

[nxp.com/support](http://nxp.com/support)

**Limited warranty and liability** — Information in this document is believed to be accurate and reliable. However, NXP Semiconductors does not give any representations or warranties, expressed or implied, as to the accuracy or completeness of such information and shall have no liability for the consequences of use of such information. NXP Semiconductors takes no responsibility for the content in this document if provided by an information source outside of NXP Semiconductors. In no event shall NXP Semiconductors be liable for any indirect, incidental, punitive, special or consequential damages (including - without limitation - lost profits, lost savings, business interruption, costs related to the removal or replacement of any products or rework charges) whether or not such damages are based on tort (including negligence), warranty, breach of contract or any other legal theory.

Notwithstanding any damages that customer might incur for any reason whatsoever, NXP Semiconductors' aggregate and cumulative liability towards customer for the products described herein shall be limited in accordance with the Terms and conditions of commercial sale of NXP Semiconductors.

**Right to make changes** - NXP Semiconductors reserves the right to make changes to information published in this document, including without limitation specifications and product descriptions, at any time and without notice. This document supersedes and replaces all information supplied prior to the publication hereof.

**Security** — Customer understands that all NXP products may be subject to unidentified or documented vulnerabilities. Customer is responsible for the design and operation of its applications and products throughout their lifecycles to reduce the effect of these vulnerabilities on customer's applications and products. Customer's responsibility also extends to other open and/or proprietary technologies supported by NXP products for use in customer's applications. NXP accepts no liability for any vulnerability. Customer should regularly check security updates from NXP and follow up appropriately.

Customer shall select products with security features that best meet rules, regulations, and standards of the intended application and make the ultimate design decisions regarding its products and is solely responsible for compliance with all legal, regulatory, and security related requirements concerning its products, regardless of any information or support that may be provided by NXP. NXP has a Product Security Incident Response Team (PSIRT) (reachable at [PSIRT@nxp.com](mailto:PSIRT@nxp.com)) that manages the investigation, reporting, and solution release to security vulnerabilities of NXP products.

**Suitability for use** — NXP Semiconductors products are not designed, authorized or warranted to be suitable for use in life support, life-critical or safety-critical systems or equipment, nor in applications where failure or malfunction of an NXP Semiconductors product can reasonably be expected to result in personal injury, death or severe property or environmental damage. NXP Semiconductors and its suppliers accept no liability for inclusion and/or use of NXP Semiconductors products in such equipment or applications and therefore such inclusion and/or use is at the customer's own risk.

**Non-automotive qualified products** — Unless this data sheet expressly states that this specific NXP Semiconductors product is automotive qualified, the product is not suitable for automotive use. It is neither qualified nor tested in accordance with automotive testing or application requirements. NXP Semiconductors accepts no liability for inclusion and/or use of non-automotive qualified products in automotive equipment or applications.

In the event that customer uses the product for design-in and use in automotive applications to automotive specifications and standards, customer (a) shall use the product without NXP Semiconductors' warranty of the product for such automotive applications, use and specifications, and (b) whenever customer uses the product for automotive applications beyond NXP Semiconductors' specifications such use shall be solely at customer's own risk, and (c) customer fully indemnifies NXP Semiconductors for any liability, damages or failed product claims resulting from customer design and use of the product for automotive applications beyond NXP Semiconductors' standard warranty and NXP Semiconductors' product specifications.

**Applications** — Applications that are described herein for any of these products are for illustrative purposes only. NXP Semiconductors makes no representation or warranty that such applications will be suitable for the specified use without further testing or modification.

Customers are responsible for the design and operation of their applications and products using NXP Semiconductors products, and NXP Semiconductors accepts no liability for any assistance with applications or customer product

*Table continues on the next page...*

design. It is customer's sole responsibility to determine whether the NXP Semiconductors product is suitable and fit for the customer's applications and products planned, as well as for the planned application and use of customer's third party customer(s). Customers should provide appropriate design and operating safeguards to minimize the risks associated with their applications and products.

NXP Semiconductors does not accept any liability related to any default, damage, costs or problem which is based on any weakness or default in the customer's applications or products, or the application or use by customer's third party customer(s). Customer is responsible for doing all necessary testing for the customer's applications and products using NXP Semiconductors products in order to avoid a default of the applications and the products or of the application or use by customer's third party customer(s). NXP does not accept any liability in this respect.

**Limiting values** — Stress above one or more limiting values (as defined in the Absolute Maximum Ratings System of IEC 60134) will cause permanent damage to the device. Limiting values are stress ratings only and (proper) operation of the device at these or any other conditions above those given in the Recommended operating conditions section (if present) or the Characteristics sections of this document is not warranted. Constant or repeated exposure to limiting values will permanently and irreversibly affect the quality and reliability of the device.

**Terms and conditions of commercial sale** — NXP Semiconductors products are sold subject to the general terms and conditions of commercial sale, as published at <http://www.nxp.com/profile/terms>, unless otherwise agreed in a valid written individual agreement. In case an individual agreement is concluded only the terms and conditions of the respective agreement shall apply. NXP Semiconductors hereby expressly objects to applying the customer's general terms and conditions with regard to the purchase of NXP Semiconductors products by customer.

**Hazardous voltage** — Although basic supply voltages of the product may be much lower, circuit voltages up to 60 V may appear when operating this product, depending on settings and application. Customers incorporating or otherwise using these products in applications where such high voltages may appear during operation, assembly, test etc. of such application, do so at their own risk. Customers agree to fully indemnify NXP Semiconductors for any damages resulting from or in connection with such high voltages. Furthermore, customers are drawn to safety standards (IEC 950, EN 60 950, CENELEC, ISO, etc.) and other (legal) requirements applying to such high voltages.

**Export control** — This document as well as the item(s) described herein may be subject to export control regulations. Export might require a prior authorization from competent authorities.

NXP, the NXP logo, NXP SECURE CONNECTIONS FOR A SMARTER WORLD, COOLFLUX, EMBRACE, GREENCHIP, HITAG, ICODE, JCOP, LIFE, VIBES, MIFARE, MIFARE CLASSIC, MIFARE DESFire, MIFARE PLUS, MIFARE FLEX, MANTIS, MIFARE ULTRALIGHT, MIFARE4MOBILE, MIGLO, NTAG, ROADLINK, SMARTLX, SMARTMX, STARPLUG, TOPFET, TRENCHMOS, UCODE, Freescale, the Freescale logo, Altivec, CodeWarrior, ColdFire, ColdFire+, the Energy Efficient Solutions logo, Kinetis, Layerscape, MagniV, mobileGT, PEG, PowerQUICC, Processor Expert, QorIQ, QorIQ Qonverge, SafeAssure, the SafeAssure logo, StarCore, Symphony, VortiQa, Vybrid, Airfast, BeeKit, BeeStack, CoreNet, Flexis, MXC, Platform in a Package, QUICC Engine, Tower, TurboLink, EdgeScale, EdgeLock, eIQ, and Immersive3D are trademarks of NXP B.V. All other product or service names are the property of their respective owners. AMBA, Arm, Arm7, Arm7TDMI, Arm9, Arm11, Artisan, big.LITTLE, Cordio, CoreLink, CoreSight, Cortex, DesignStart, DynamIQ, Jazelle, Keil, Mali, Mbed, Mbed Enabled, NEON, POP, RealView, SecurCore, Socrates, Thumb, TrustZone, ULINK, ULINK2, ULINK-ME, ULINK-PLUS, ULINKpro,  $\mu$ Vision, Versatile are trademarks or registered trademarks of Arm Limited (or its subsidiaries) in the US and/or elsewhere. The related technology may be protected by any or all of patents, copyrights, designs and trade secrets. All rights reserved. Oracle and Java are registered trademarks of Oracle and/or its affiliates. M, M Mobileye and other Mobileye trademarks or logos appearing herein are trademarks of Mobileye Vision Technologies Ltd. in the United States, the EU and/or other jurisdictions.



arm

© NXP B.V. 2007-2021.

All rights reserved.

For more information, please visit: <http://www.nxp.com>

For sales office addresses, please send an email to: [salesaddresses@nxp.com](mailto:salesaddresses@nxp.com)

Date of release: April, 2021

Document identifier: MCF54455