

FSB70625

Motion SPM® 7 Series

Features

- UL Certified No. E209204 (UL1557)
- High Performance PQFN Package
- 250 V $R_{DS(on)} = 0.8 \Omega(\text{Max})$ FRFET MOSFET 3-Phase Inverter with Gate Drivers and Protection
- Separate Open-Source Pins from Low-Side MOSFETs for Three-Phase Current-Sensing
- Active-HIGH Interface, Works with 3.3 / 5 V Logic, Schmitt-trigger Input
- Optimized for Low Electromagnetic Interference
- HVIC Temperature-Sensing Built-In for Temperature Monitoring
- HVIC for Gate Driving with Under-Voltage Protection and Interlock Function
- Isolation Rating: 1500 V_{rms} / min.
- Moisture Sensitive Level (MSL) 3
- RoHS Compliant

Application

- 3-Phase Inverter Driver for Small Power AC Motor Drives

Related Source

- [AN-9077 - Motion SPM® 7 Series User's Guide](#)
- [AN-9078 - Surface Mount Guidelines for Motion SPM® 7 Series](#)

General Description

The FSB70625 is an advanced Motion SPM® 7 module providing a fully-featured, high-performance inverter output stage for AC Induction, BLDC and PMSM motors. These modules integrate optimized gate drive of the built-in MOSFETs (FRFET® technology) to minimize EMI and losses, while also providing multiple on-module protection features including under-voltage lockouts, thermal monitoring, fault reporting and interlock function. The built-in one HVIC translates the incoming logic-level gate inputs to the high-voltage, high-current drive signals required to properly drive the module's internal MOSFETs. Separate open-source MOSFET terminals are available for each phase to support the widest variety of control algorithms.

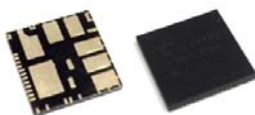

Package Marking & Ordering Information

Device Marking	Device	Package	Reel Size	Tape Width	Quantity
FSB70625	FSB70625	PQFN27A	13"	24 mm	1000 units

Absolute Maximum Ratings

Inverter Part (each MOSFET unless otherwise specified.)

Symbol	Parameter	Conditions	Rating	Unit
V_{DSS}	Drain-Source Voltage of Each MOSFET		250	V
$*I_{D25}$	Each MOSFET Drain Current, Continuous	$T_{CB} = 25^{\circ}\text{C}$ (1st Note 1)	6.9	A
$*I_{D80}$	Each MOSFET Drain Current, Continuous	$T_{CB} = 80^{\circ}\text{C}$	5.2	A
$*I_{DP}$	Each MOSFET Drain Current, Peak	$T_{CB} = 25^{\circ}\text{C}$, $PW < 100 \mu\text{s}$	13.9	A
$*P_D$	Maximum Power Dissipation	$T_{CB} = 25^{\circ}\text{C}$, For Each MOSFET	81	W

Control Part (each HVIC unless otherwise specified.)

Symbol	Parameter	Conditions	Rating	Unit
V_{DD}	Control Supply Voltage	Applied Between V_{DD} and COM	20	V
V_{BS}	High-side Bias Voltage	Applied Between V_B and V_S	20	V
V_{IN}	Input Signal Voltage	Applied Between IN and COM	$-0.3 \sim V_{DD} + 0.3$	V
V_{FO}	Fault Output Supply Voltage	Applied Between FO and COM	$-0.3 \sim V_{DD} + 0.3$	V
I_{FO}	Fault Output Current	Sink Current FO Pin	5	mA
V_{CSC}	Current Sensing Input Voltage	Applied Between Csc and COM	$-0.3 \sim V_{DD} + 0.3$	V

Total System

Symbol	Parameter	Conditions	Rating	Unit
T_J	Operating Junction Temperature		$-40 \sim 150$	$^{\circ}\text{C}$
T_{STG}	Storage Temperature		$-40 \sim 125$	$^{\circ}\text{C}$
V_{ISO}	Isolation Voltage	60 Hz, Sinusoidal, 1 Minute, Connection Pins to Heat Sink Plate	1500	V_{rms}

1st Notes:

- T_{CB} is pad temperature of case bottom.
- Marking "*" is calculation value or design factor.

Pin descriptions

Pin Number	Pin Name	Pin Description
1	/FO	Fault Output
2	V_{TS}	Voltage Output of HVIC Temperature
3	Cfod	Capacitor for Duration of Fault Output
4	Csc	Capacitor (Low-pass Filter) for Short-circuit Current Detection Input
5	V_{DD}	Supply Bias Voltage for IC and MOSFETs Driving
6	IN_UH	Signal Input for High-side U Phase
7	IN_VH	Signal Input for High-side V Phase
8 (8a)	COM	Common Supply Ground
9	IN_WH	Signal Input for High-side W Phase
10	IN_UL	Signal Input for Low-side U Phase
11	IN_VL	Signal Input for Low-side V Phase
12	IN_WL	Signal Input for Low-side W Phase
13	Nu	Negative DC-Link Input for U Phase
14	U	Output for U Phase
15	Nv	Negative DC-Link Input for V Phase
16	V	Output for V Phase
17	W	Output for W Phase
18	Nw	Negative DC-Link Input for W Phase
19	$V_{S(W)}$	High-side Bias Voltage Ground for W phase Mosfet driving
20	P_W	Positive DC-Link Input for W Phase
21	P_V	Positive DC-Link Input for V Phase
22	P_U	Positive DC-Link Input for U Phase
23 (23a)	$V_{S(V)}$	High-side Bias Voltage Ground for V phase Mosfet driving
24 (24a)	$V_{S(U)}$	High-side Bias Voltage Ground for U phase Mosfet driving
25	$V_{B(U)}$	High-side Bias Voltage for U phase Mosfet driving
26	$V_{B(V)}$	High-side Bias Voltage for V phase Mosfet driving
27	$V_{B(W)}$	High-side Bias Voltage for W phase Mosfet driving

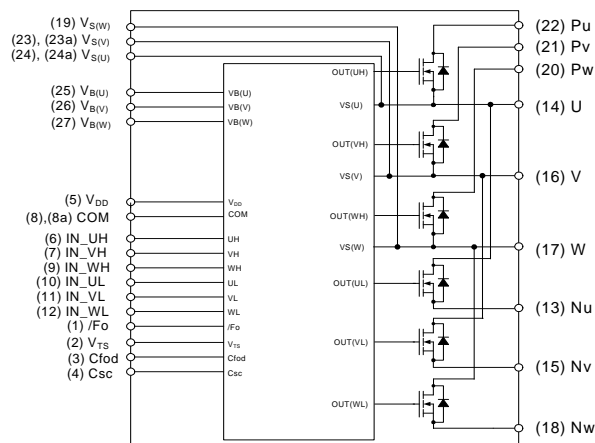

Figure 1. Pin Configuration and Internal Block Diagram

1st Notes:

- Source terminal of each low-side MOSFET is not connected to supply ground or bias voltage ground inside Motion SPM® 7 product. External connections should be made as indicated in Figure 2.
- The suffix -a pad is connected with same number pin. ex) 8 and 8a is connected inside.

Electrical Characteristics (T_J = 25°C, V_{DD} = V_{BS} = 15 V unless otherwise specified.)

Inverter Part (each MOSFET unless otherwise specified.)

Symbol	Parameter	Conditions	Min	Typ	Max	Unit
BV _{DSS}	Drain - Source Breakdown Voltage	V _{IN} = 0 V, I _D = 1 mA (2nd Note 1)	250	-	-	V
I _{DSS}	Zero Gate Voltage Drain Current	V _{IN} = 0 V, V _{DS} = 250 V	-	-	1	mA
R _{DS(on)}	Static Drain - Source Turn-On Resistance	V _{DD} = V _{BS} = 15 V, V _{IN} = 5 V, I _D = 1.0 A	-	0.7	0.8	Ω
V _{SD}	Drain - Source Diode Forward Voltage	V _{DD} = V _{BS} = 15V, V _{IN} = 0 V, I _D = -1.0 A	-	0.9	1.2	V
t _{ON}	Switching Times	V _{PN} = 150 V, V _{DD} = V _{BS} = 15 V, I _D = 1.0 A V _{IN} = 0 V ↔ 5 V, Inductive Load L = 3 mH Low-Side MOSFET Switching (2nd Note 2)	-	495	-	ns
t _{D(ON)}			-	415	-	ns
t _{OFF}			-	370	-	ns
t _{D(OFF)}			-	275	-	ns
I _{rr}			-	1.8	-	A
t _{rr}			-	70	-	ns
E _{ON}			-	20	-	μJ
E _{OFF}			-	1.7	-	μJ

Control Part (each HVIC unless otherwise specified.)

Symbol	Parameter	Conditions	Min	Typ	Max	Units	
I _{QDD}	Quiescent V _{DD} Current	V _{DD} =15V, V _{IN} =0V	V _{DD} - COM	-	1.7	3.0 mA	
I _{QBS}	Quiescent V _{BS} Current	V _{BS} =15V, V _{IN} =0V	V _{B(X)} -V _{S(X)} , V _{B(V)} -V _{S(V)} , V _{B(W)} -V _{S(W)}	-	45	70 μA	
I _{PDD}	Operating V _{DD} Current	V _{DD} =15V, F _{PWM} =20kHz, duty=50%, PWM signal input for Low side	V _{DD} - COM	-	1.9	3.2 mA	
I _{PBS}	Operating V _{BS} Current	V _{BS} =15V, F _{PWM} =20kHz, duty=50%, PWM signal input for High side	V _{B(U)} -V _{S(U)} , V _{B(V)} -V _{S(V)} , V _{B(W)} -V _{S(W)}	-	300	400 μA	
UV _{DDD}	Low-side Undervoltage Protection (Figure 6)	V _{DD} Undervoltage Protection Detection Level	7.4	8.0	9.4	V	
UV _{DDR}		V _{DD} Undervoltage Protection Reset Level	8.0	8.9	9.8	V	
UV _{BSD}	High-side Undervoltage Protection (Figure 7)	V _{BS} Undervoltage Protection Detection Level	7.4	8.0	9.4	V	
UV _{BSR}		V _{BS} Undervoltage Protection Reset Level	8.0	8.9	9.8	V	
V _{TS}	HVIC Temperature sensing voltage output	V _{DD} =15V, T _{HVIC} =25°C (2nd Note 3)	580	675	770	mV	
V _{IH}	ON Threshold Voltage	Logic High Level	IN - COM	-	-	2.4	V
V _{IL}	OFF Threshold Voltage	Logic Low Level		0.8	-	-	V
V _{SC(ref)}	SC Current Trip Level	V _{DD} =15V	C _{SC} - COM	0.45	0.5	0.55	V
t _{FOD}	Fault-out Pulse Width	C _{FOD} =33nF (2nd Note 4)	1.0	1.4	1.8	ms	

2nd Notes:

- BV_{DSS} is the absolute maximum voltage rating between drain and source terminal of each MOSFET inside Motion SPM® 7 product. V_{PN} should be sufficiently less than this value considering the effect of the stray inductance so that V_{PN} should not exceed BV_{DSS} in any case.
- t_{ON} and t_{OFF} include the propagation delay of the internal drive IC. Listed values are measured at the laboratory test condition, and they can be different according to the field applications due to the effect of different printed circuit boards and wirings. Please see Figure 3 for the switching time definition with the switching test circuit of Figure 4.
- V_{TS} is only for sensing-temperature of module and cannot shutdown MOSFETs automatically.
- The fault-out pulse width t_{FOD} depends on the capacitance value of C_{FOD} according to the following approximate equation : C_{FOD} = 24 × 10⁻⁶ × t_{FOD} [F]

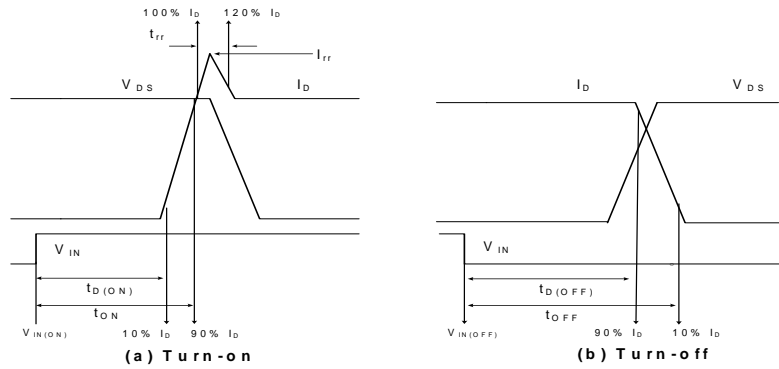

Figure 3. Switching Time Definition

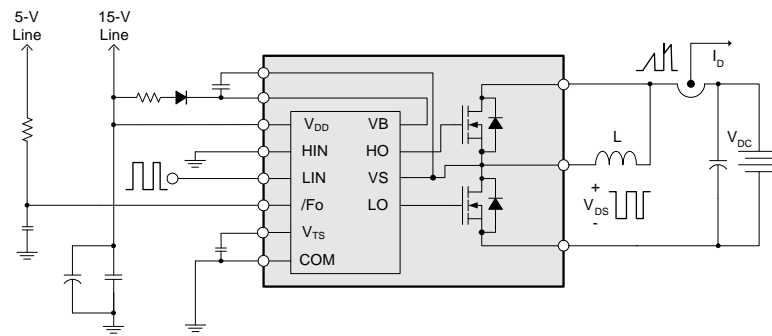

Figure 4. Switching Test Circuit (Low-side)

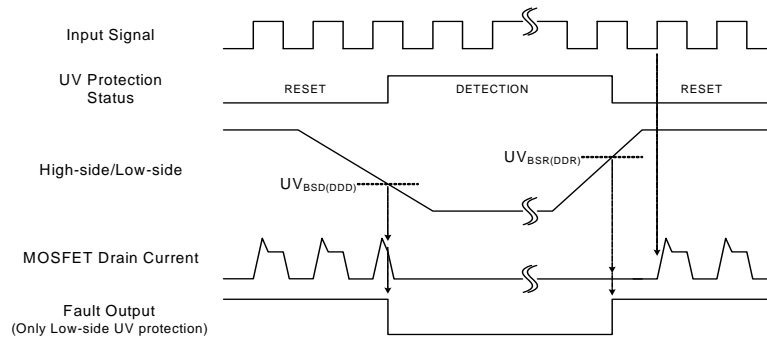

Figure 5. Under Voltage Protection

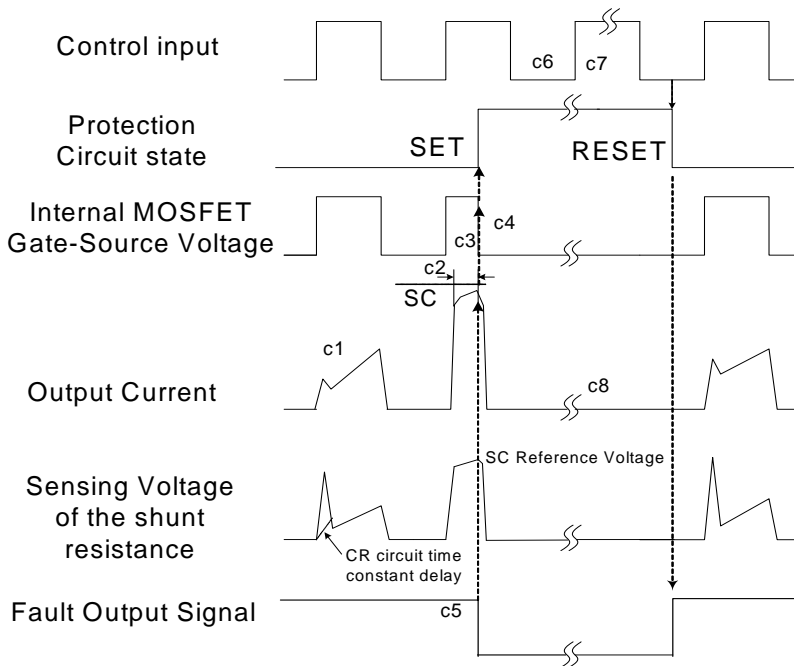

Figure 6. Short-Circuit Current Protection

(with the external shunt resistance and CR connection)

- c1 : Normal operation: MOSFET ON and carrying current.
- c2 : Short circuit current detection (SC trigger).
- c3 : Hard MOSFET gate interrupt.
- c4 : MOSFET turns OFF.
- c5 : Fault output timer operation start : Fault-out width (t_{FOD})
- c6 : Input "L" : MOSFET OFF state.
- c7 : Input "H" : MOSFET ON state, but during the active period of fault output the MOSFET doesn't turn ON.
- c8 : MOSFET OFF state

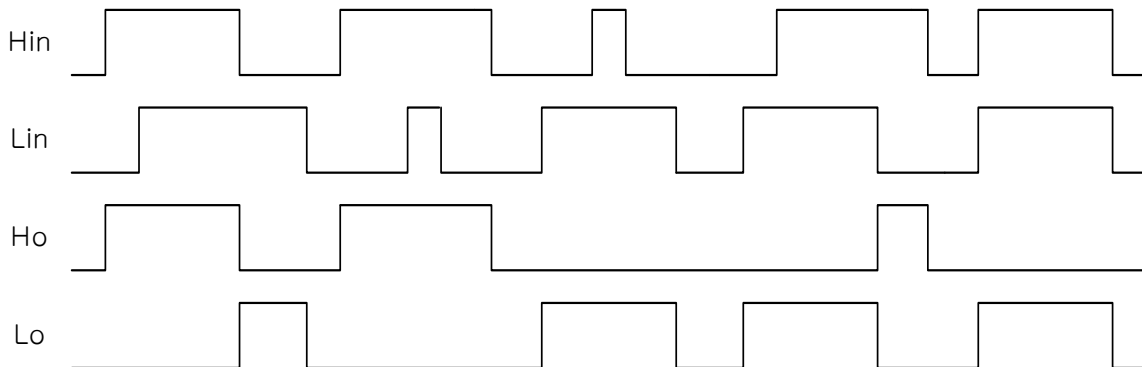

Figure 7. Timing Chart of Interlock Function

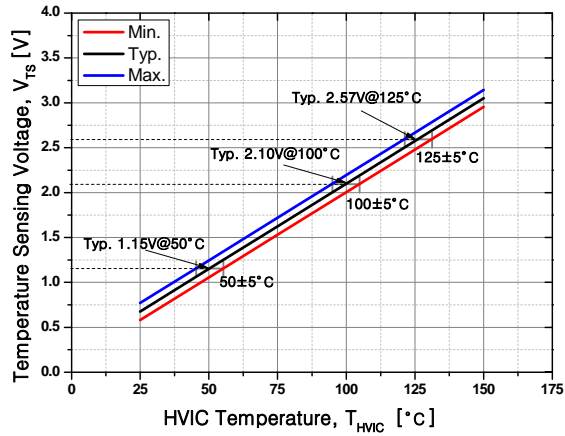

Figure 8. Temperature profile V_{TS} vs. T_{HVIC}

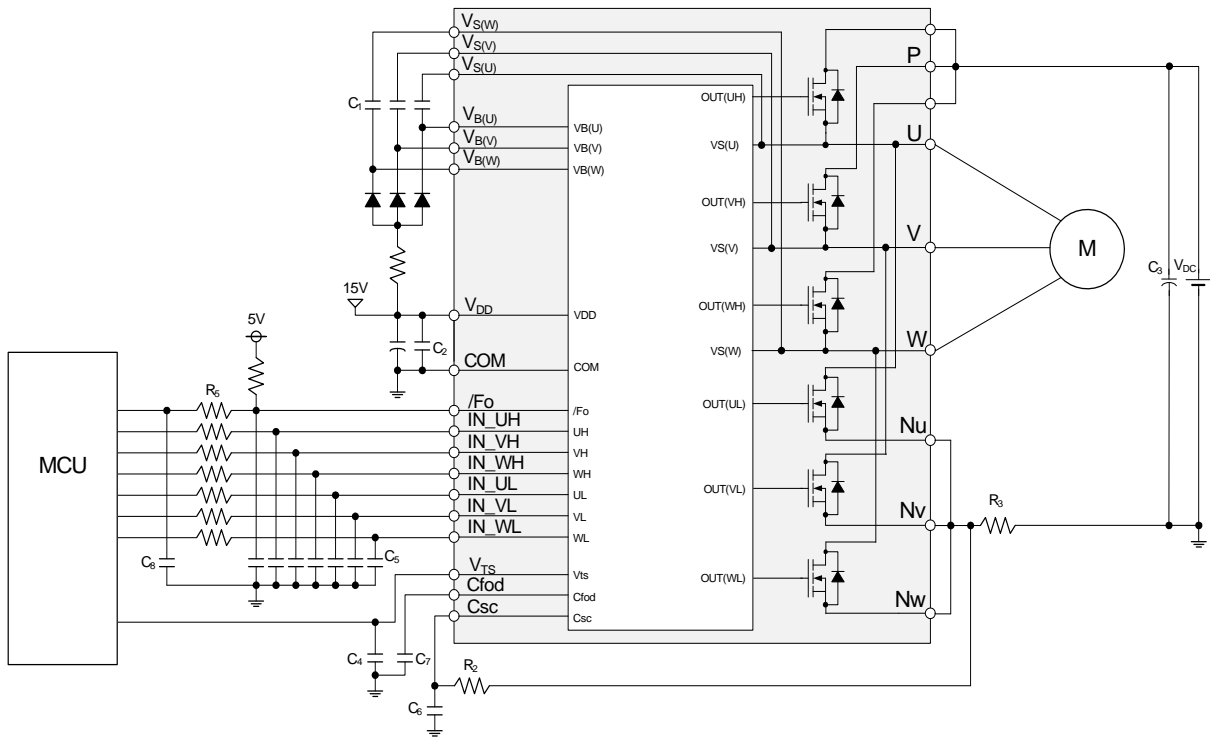
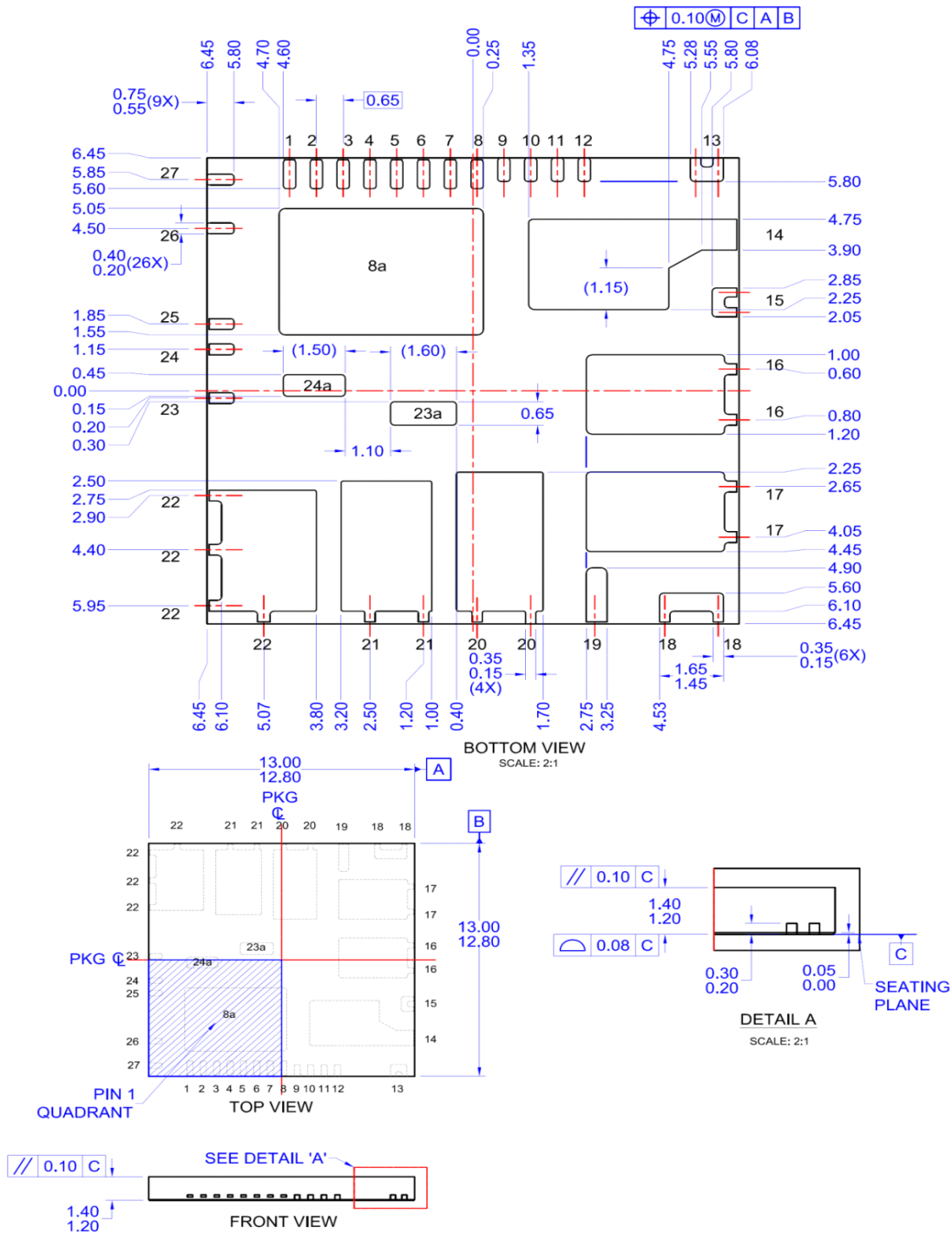

Figure 9. Example of Application Circuit

4th Notes:

1. RC-coupling (R_5 and C_5 , R_2 and C_6) and C_1 , C_5 , C_7 , C_8 at each input of Motion SPM® 7 product and MCU are useful to prevent improper input signal caused by surge-noise.
2. Ground-wires and output terminals, should be thick and short in order to avoid surge-voltage and malfunction of HVIC.
3. All the filter capacitors should be connected close to Motion SPM 7 product, and they should have good characteristics for rejecting high-frequency ripple current.

Detailed Package Outline Drawings



Package drawings are provided as a service to customers considering Fairchild components. Drawings may change in any manner without notice. Please note the revision and/or data on the drawing and contact a Fairchild Semiconductor representative to verify or obtain the most recent revision. Package specifications do not expand the terms of Fairchild's worldwide terms and conditions, specifically the the warranty therein, which covers Fairchild products.

Always visit Fairchild Semiconductor's online packaging area for the most recent package drawings:

<http://www.fairchildsemi.com/dwg/PQ/PQFN27A.pdf>

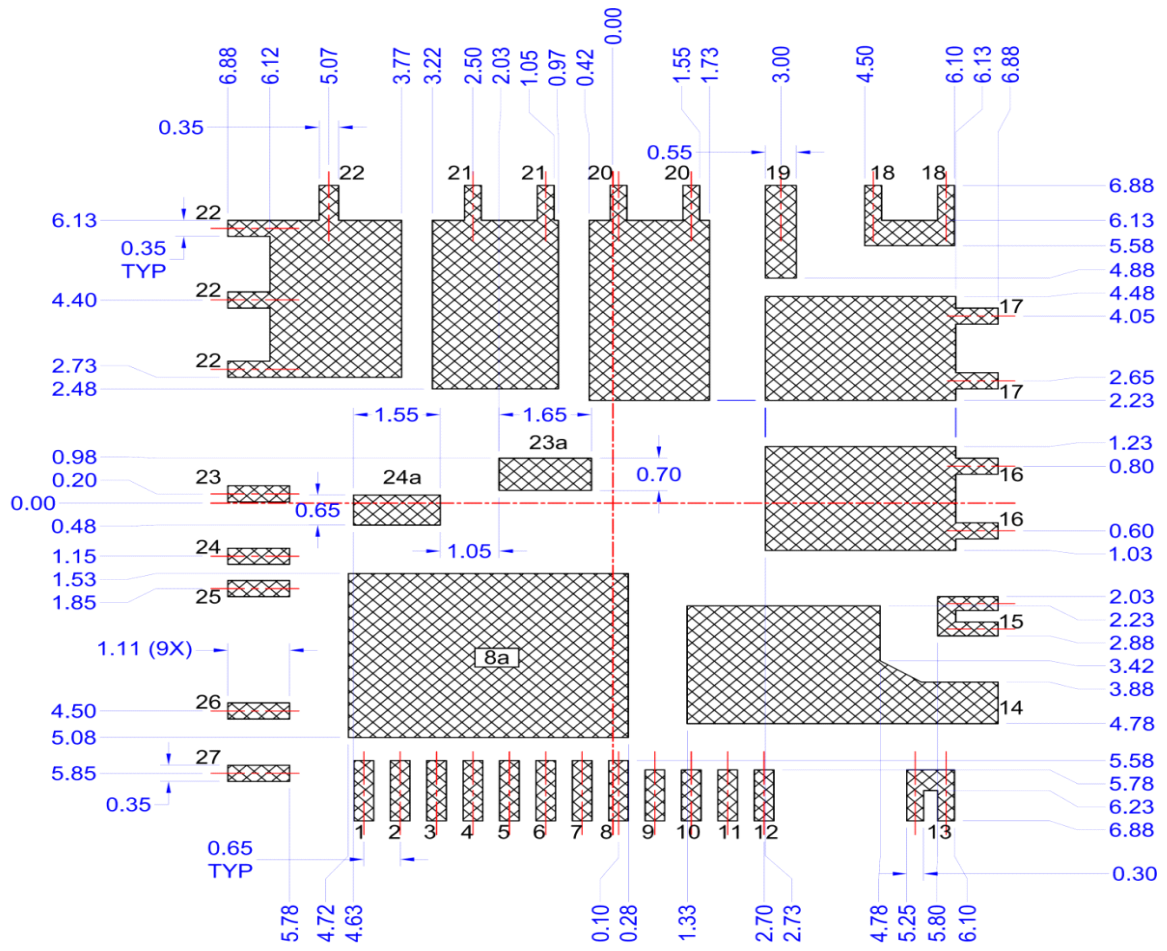

LAND PATTERN
RECOMMENDATION
SCALE: 2:1





NOTES: UNLESS OTHERWISE SPECIFIED

- A) THIS PACKAGE IS NOT PRESENTLY REGISTERED TO ANY STANDARD COMMITTEE.
- B) DIMENSIONS DO NOT INCLUDE BURRS OR MOLD FLASH. MOLD FLASH OR BURRS DOES NOT EXCEED 0.10MM.
- C) ALL DIMENSIONS ARE IN MILLIMETERS.
- D) DRAWING CONFORMS TO ASME Y14.5M-1994.
- E) LAND PATTERN REFERENCE:
QFN65P1290X1290X140-40N-40N
- F) DRAWING FILE NAME: MKT-PQFN27AREV3.
- G) IT IS NOT NECESSARY TO SOLDER 23a AND 24a, AND CAN BE OMITTED FROM THE FOOTPRINT
- H) FAIRCHILD SEMICONDUCTOR



TRADEMARKS

The following includes registered and unregistered trademarks and service marks, owned by Fairchild Semiconductor and/or its global subsidiaries, and is not intended to be an exhaustive list of all such trademarks.

- | | | | |
|---|--|---|---|
| AccuPower™ | F-PFS™ |  | Sync-Lock™ |
| AX-CAP®* | FRFET® | PowerTrench® |  SYSTEM GENERAL® |
| BitSiC™ | Global Power Resource™ | PowerXS™ | TinyBoost® |
| Build it Now™ | GreenBridge™ | Programmable Active Droop™ | TinyBuck® |
| CorePLUS™ | Green FPS™ | QFET® | TinyCalc™ |
| CorePOWER™ | Green FPS™ e-Series™ | QS™ | TinyLogic® |
| CROSSVOLT™ | Gmax™ | Quiet Series™ | TINYOPTO™ |
| CTL™ | GTO™ | RapidConfigure™ | TinyPower™ |
| Current Transfer Logic™ | IntelliMAX™ |  Saving our world, 1mW/W/kW at a time™ | TinyPWM™ |
| DEUXPEED® | ISOPLANAR™ | SignalWise™ | TinyWire™ |
| Dual Cool™ | Making Small Speakers Sound Louder and Better™ | SmartMax™ | TranSiC™ |
| EcoSPARK® | MegaBuck™ | SMART START™ | TriFault Detect™ |
| EfficientMax™ | MICROCOUPLER™ | Solutions for Your Success™ | TRUECURRENT®* |
| ESBC™ | MicroFET™ | SPM® |  SerDes™ |
|  | MicroPak™ | STEALTH™ | UHC® |
| Fairchild® | MicroPak2™ | SuperFET® | Ultra FRFET™ |
| Fairchild Semiconductor® | MillerDrive™ | SuperSOT™-3 | UniFET™ |
| FACT Quiet Series™ | MotionMax™ | SuperSOT™-6 | VCX™ |
| FACT® | mWSaver® | SuperSOT™-8 | VisualMax™ |
| FAST® | OptoHiT™ | SupreMOS® | VoltagePlus™ |
| FastvCore™ | OPTOLOGIC® | SyncFET™ | XS™ |
| FETBench™ | OPTOPLANAR® | | |
| FPS™ | | | |

* Trademarks of System General Corporation, used under license by Fairchild Semiconductor.

DISCLAIMER

FAIRCHILD SEMICONDUCTOR RESERVES THE RIGHT TO MAKE CHANGES WITHOUT FURTHER NOTICE TO ANY PRODUCTS HEREIN TO IMPROVE RELIABILITY, FUNCTION, OR DESIGN. FAIRCHILD DOES NOT ASSUME ANY LIABILITY ARISING OUT OF THE APPLICATION OR USE OF ANY PRODUCT OR CIRCUIT DESCRIBED HEREIN; NEITHER DOES IT CONVEY ANY LICENSE UNDER ITS PATENT RIGHTS, NOR THE RIGHTS OF OTHERS. THESE SPECIFICATIONS DO NOT EXPAND THE TERMS OF FAIRCHILD'S WORLDWIDE TERMS AND CONDITIONS, SPECIFICALLY THE WARRANTY THEREIN, WHICH COVERS THESE PRODUCTS.

LIFE SUPPORT POLICY

FAIRCHILD'S PRODUCTS ARE NOT AUTHORIZED FOR USE AS CRITICAL COMPONENTS IN LIFE SUPPORT DEVICES OR SYSTEMS WITHOUT THE EXPRESS WRITTEN APPROVAL OF FAIRCHILD SEMICONDUCTOR CORPORATION.

As used herein:

1. Life support devices or systems are devices or systems which, (a) are intended for surgical implant into the body or (b) support or sustain life, and (c) whose failure to perform when properly used in accordance with instructions for use provided in the labeling, can be reasonably expected to result in a significant injury of the user.
2. A critical component in any component of a life support, device, or system whose failure to perform can be reasonably expected to cause the failure of the life support device or system, or to affect its safety or effectiveness.

ANTI-COUNTERFEITING POLICY

Fairchild Semiconductor Corporation's Anti-Counterfeiting Policy. Fairchild's Anti-Counterfeiting Policy is also stated on our external website, www.fairchildsemi.com, under Sales Support.

Counterfeiting of semiconductor parts is a growing problem in the industry. All manufacturers of semiconductor products are experiencing counterfeiting of their parts. Customers who inadvertently purchase counterfeit parts experience many problems such as loss of brand reputation, substandard performance, failed applications, and increased cost of production and manufacturing delays. Fairchild is taking strong measures to protect ourselves and our customers from the proliferation of counterfeit parts. Fairchild strongly encourages customers to purchase Fairchild parts either directly from Fairchild or from Authorized Fairchild Distributors who are listed by country on our web page cited above. Products customers buy either from Fairchild directly or from Authorized Fairchild Distributors are genuine parts, have full traceability, meet Fairchild's quality standards for handling and storage and provide access to Fairchild's full range of up-to-date technical and product information. Fairchild and our Authorized Distributors will stand behind all warranties and will appropriately address any warranty issues that may arise. Fairchild will not provide any warranty coverage or other assistance for parts bought from Unauthorized Sources. Fairchild is committed to combat this global problem and encourage our customers to do their part in stopping this practice by buying direct or from authorized distributors.

PRODUCT STATUS DEFINITIONS

Definition of Terms

Datasheet Identification	Product Status	Definition
Advance Information	Formative / In Design	Datasheet contains the design specifications for product development. Specifications may change in any manner without notice.
Preliminary	First Production	Datasheet contains preliminary data; supplementary data will be published at a later date. Fairchild Semiconductor reserves the right to make changes at any time without notice to improve design.
No Identification Needed	Full Production	Datasheet contains final specifications. Fairchild Semiconductor reserves the right to make changes at any time without notice to improve the design.
Obsolete	Not In Production	Datasheet contains specifications on a product that is discontinued by Fairchild Semiconductor. The datasheet is for reference information only.

Rev. 166