

Stratos 100G Transceivers

QSFP28 100G SR4 MMF 850nm Transceiver



Features

- 850nm VCSEL laser
- 100Gb/s aggregated bidirectional data throughput
- Contain clock and data recovery (CDR)
- Supports 100 Gbps data rate links of up to 70m via OM3 MMF and 100m via OM4 MMF
- 3.3 V single power supply
- Power consumption < 3.5 W
- Hot pluggable electrical interface
- Standard 12/8 lane optical fiber with MPO optical connector
- Compliant with QSFP28 MSA-SFF-8665 and IEEE 802.3bm 100Gbase-SR4
- Digital diagnostic functions (Via I²C)
- Compliant with UL & TUV



Applications

- 100Gb/s Ethernet 100GBase-SR4, MPO
- Proprietary multi-channel links

Part Numbers

Part Number	Form Factor	Data Rate	Media	Distance	Wavelength	Voltage	Coupling	DDM	Temperature
STA-100G-SR4	QSFP28 MPO	100G	MMF	70m (OM3) 100m (OM4)	850 nm	3.3 V	AC/AC	Y	0 ~ +70 C

Absolute Maximum Ratings

Parameter	Symbol	Conditions	Min	Max	Unit
Storage Temperature	T_s		-40	+85	°C
Supply Relative Humidity	RH	Non condensing	5	85	%
Supply Voltage	V_{cc}		-0.5	3.6	V

Recommended Operating Conditions

Parameter	Symbol	Conditions	Min	Typical	Max	Unit
Case operating temperature	T_c		0		70	°C
Supply voltage	V_{cc}		3.13	3.3	3.47	V
Supply current	I_{cc}		0		1000	mA
Data rate	DR			100		Gbps
Distance					70 (OM3) 100 (OM4)	m

Electrical Characteristics

Parameter	Symbol	Conditions	Min	Typical	Max	Unit
Transmitter						
Data input differential peak-to peak voltage swing	$V_{in,pp}$	AC coupled internally	20		950	mVpp
LOS assert threshold	$V_{in,pp\ LOS}$	Tx data input differential peak-to-peak voltage swing	120			mVpp
Receiver						
Data output differential peak-to peak voltage swing, each lane	ΔVDO_{pp}	AC coupled with 100 ohm differential output impedance	300		800	mVpp

Optical Characteristics

Parameter	Symbol	Min	Typical	Max	Unit	Notes
Transmitter						
Signaling rate, each lane			25.78125		GBd	
Center wavelength	λ	840		860	nm	
Spectral width – RMS	$\Delta\lambda$			0.6	nm	
Transmitter and dispersion penalty (TDP), each lane				5	dB	
Output optical power: average each lane	PO_AVE	-8.4		2.4	dBm	
Output optical modulation amplitude, each lane		-6.4		3	dBm	Even if the TDP<0.9dB, the OMA(min) must exceed this value
Extinction ratio	ER	2			dB	
Output optical power: disabled	PO_OFF			-30	dBm	
Eye mask			Compliant with IEEE 802.3bm			
Receiver						
Signaling rate, each lane			25.78125		GBd	
Center wavelength, each lane	λ	840		860	nm	
Damage threshold		3.4			dBm	
Receiver power (OMA), each lane				3	dBm	
Maximum average power at receiver input, each lane		-10.3		2.4	dBm	
Receiver reflectance				-12	dB	
Stressed receiver sensitivity (OMA)				-5.2	dBm	Measured with 25.78125 Gbps of PRBS-31 at 5×10^{-5} BER.
LOS assert		-19			dB	
LOS de-assert				-11	dB	
LOS hysteresis		0.5			dB	

Recommended Host Board Power Supply Circuit Filter

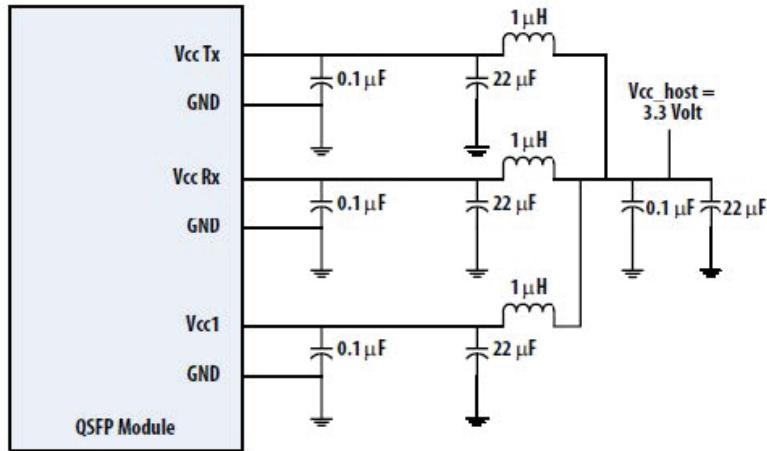

Pin Description

38	GND
37	TX1n
36	TX1p
35	GND
34	TX3n
33	TX3p
32	GND
31	LPMoDe
30	Vcc1
29	VccTx
28	IntL
27	ModPrsL
26	GND
25	RX4p
24	Rx4n
23	GND
22	RX2p
21	RX2n
20	GND

Top Side
Viewed From Top

Module Card Edge

	GND	1
	TX2n	2
	TX2p	3
	GND	4
	TX4n	5
	TX4p	6
	GND	7
	ModseL	8
	ResetL	9
	VccRx	10
	SCL	11
	SDA	12
	GND	13
	RX3p	14
	Rx3n	15
	GND	16
	RX1p	17
	RX1n	18
	GND	19

Bottom Side
Viewed From Bottom

Pin Function Definitions

Pin	Logic	Symbol	Description	Plug Sequence	Notes
1		GND	Ground	1	1
2	CML-I	Tx2n	Transmitter inverted data input	3	
3	CML-I	Tx2p	Transmitter non-inverted data input	3	
4		GND	Ground	1	1
5	CML-I	Tx4n	Transmitter inverted data input	3	
6	CML-I	Tx4p	Transmitter non-inverted data input	3	
7		GND	Ground	1	1
8	LVTTTL-IF	ModSelL	Module select	3	
9	LVTTTL-I	ResetL	Module reset	3	
10		Vcc Rx	+3.3 V power supply receiver	2	2
11	LVCMOS-I/O	SCL	2-wire serial interface clock	3	
12	LVCMOS-I/O	SDA	2-wire serial interface data	3	
13		GND	Ground	1	2
14	CML-O	Rx3p	Receiver non-inverted data output	3	
15	CML-O	Rx3n	Receiver inverted data output	3	
16		GND	Ground	1	1
17	CML-O	Rx1p	Receiver non-inverted data output	3	
18		Rx1n	Receiver inverted data output	3	
19		GND	Ground	1	1
20		GND	Ground	1	1
21	CML-O	Rx2n	Receiver inverted data output	3	
22	CML-O	Rx2p	Receiver non-inverted data output	3	
23		GND	Ground	1	1
24	CML-O	Rx4n	Receiver inverted data output	3	
25	CML-O	Rx4p	Receiver non-inverted data output	3	
26		GND	Ground	1	1
27	LVTTTL-O	ModPrsL	Module present	3	
28	LVTTTL-O	IntL	Interrupt	3	
29		Vcc Tx	+3.3 V power supply transmitter	2	2
30		Vcc1	+3.3 V power supply	2	2
31	LVTTTL-I	LPMode	Low power mode	3	
32		GND	Ground	1	1
33	CML-I	Tx3p	Transmitter non-inverted data input	3	
34	CML-I	Tx3n	Transmitter inverted data input	3	
35		GND	Ground	1	1
36	CML-I	Tx1p	Transmitter non-inverted data input	3	
37	CML-I	Tx1n	Transmitter inverted data input	3	
38		GND	Ground	1	1

1. GND is the symbol for signal and supply (power) common for the QSFP28 module. All are common within the QSFP28 module and all module voltages are referenced to this potential unless otherwise noted. Connect these directly to the host board signal-common ground plane.

2. Vcc Rx, Vcc1 and Vcc Tx are the receiver and transmitter power supplies and shall be applied concurrently. Recommended host board power supply filtering is shown in Recommended Interface Circuit. Vcc Rx, Vcc1 and Vcc Tx may be internally connected within the QSFP28 module in any combination. The connector pins are each rated for a maximum current of 1000 mA.

Stratos 100G Transceivers



Recommended Interface Circuit

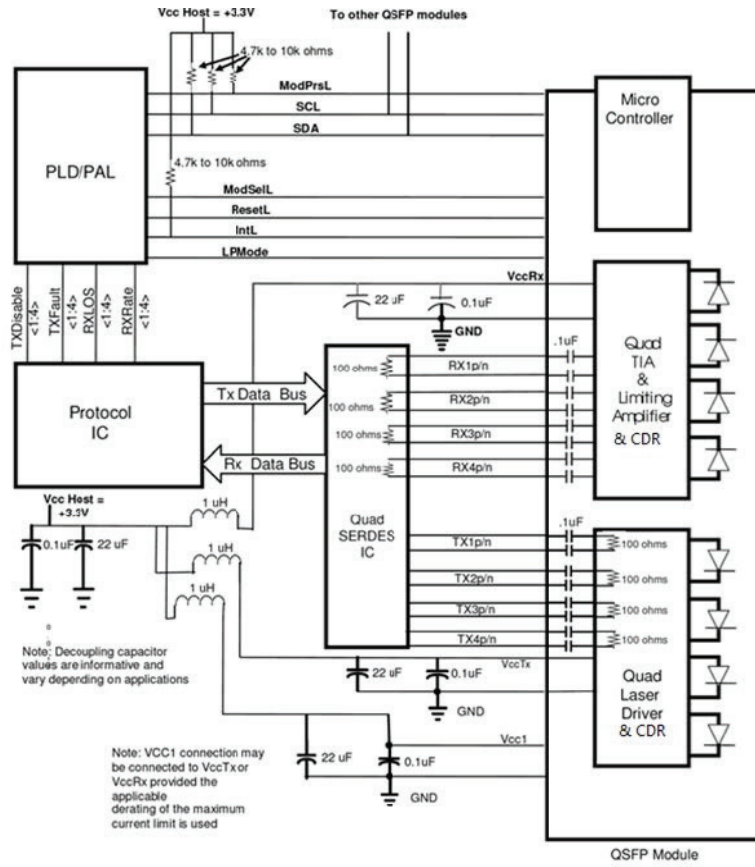

Product Label



Stratos 100G Transceivers

Ordering Information

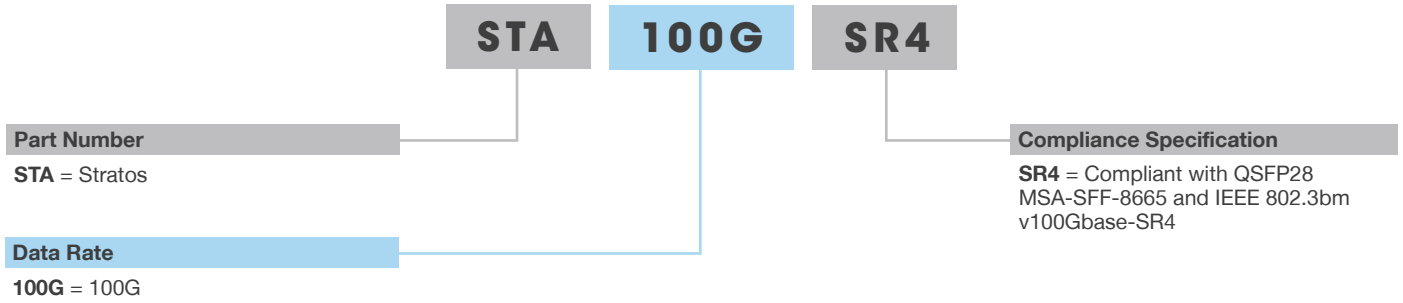

Part Drawings

Mechanical Design Diagram (mm)

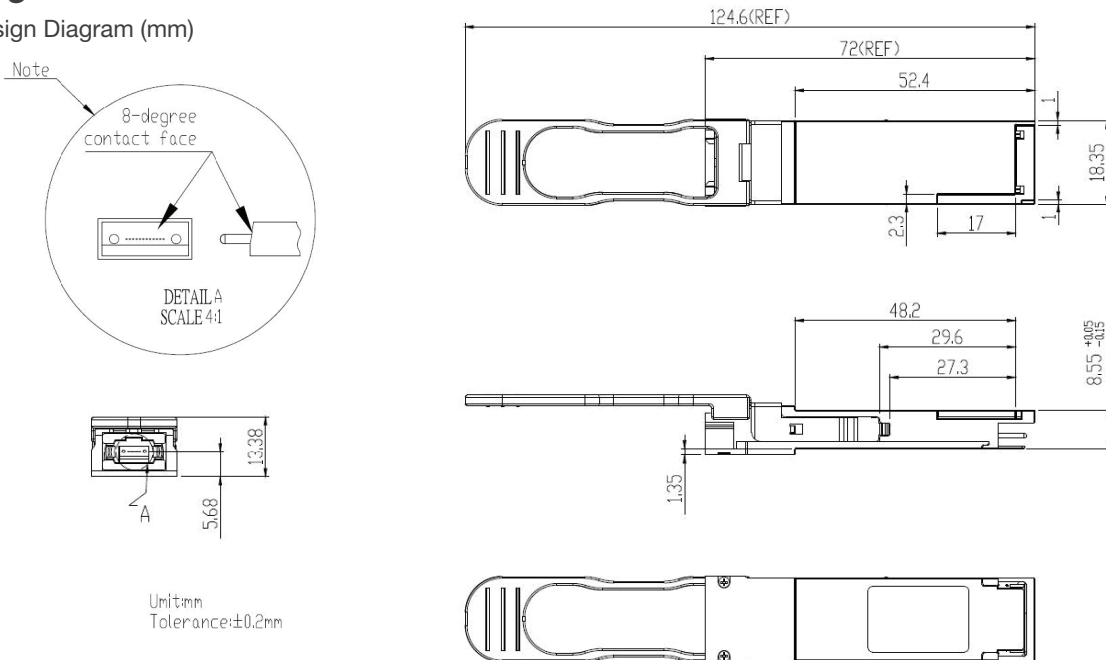

Regulatory Compliance

Item	Standard
Electromagnetic interference (EMI)	FCC part 15 Class B, EN55022 Class B (CISPR 22B), VCCI Class B
ESD (Module case)	Contact discharge EN61000-4-2 criterion B
ESD (Module case)	Air discharge EN61000-4-2 criterion B
ESD (Electrical connector)	ANSI/ESDA/JEDEC JS-001
RoHS	2011/65/EU
Laser eye safety	FDA 21CFR 1040.10 and 1040.11
Component recognition	UL and TUV

Laser Safety Information

All versions of this laser are Class 1 laser products per IEC/EN 60825-1. Users should observe safety precautions such as those recommended by ANSI Z136.1, ANSI Z36.2 and IEC 60825-1.

This product conforms to FDA (CDRH) 21 CFR 1040.10 and 1040.11 except for deviations of laser safety class designation pursuant to '**Laser Notice No.50**'

Product labeling:
Class 1 Laser Product
Compliance with 21 CFR
1040.10 and 1040.11

If labeling is not affixed to the module due to size constraints; then rather, labeling is placed on the outside of the shipping box. This product is not shipped with a power supply.

Caution: use of controls or adjustments or performance of procedures other than those specified herein may result in hazardous radiation exposure.

Certifications

UL: 62368-1
TUV: EN62368-1, EN 60825-1, EN 60825-2
Documentation is available upon request.

- (1) IEC is a registered trademark of the International Electrotechnical Commission
- (2) Within Europe the IEC standard has been adopted as a European Normative standard known as EN 60825, and each European country will have its own version of this standard, for example, the British Standards version known as BS EN 60825. There can be small differences between the different countries versions of EN 60825, and these are in part caused by the process of translating the standard into the native language of that country.
- (3) ANSI is a registered trademark of the American National Standards Institute