

# Operating Manual

# **eForce** *Battery Powered Crimping Tool*



**Table of Contents**

1	Intended use	3
2	General safety instructions	3
3	Terminology used	5
4	Symbols used on the equipment and rating plate details	5
5	Scope of delivery	6
6	Technical specifications	6
7	Brief description of the crimping tool	7
8	First use and operation	10
9	Cleaning, maintenance and repair	15
10	Disposal	17
11	Warranty	17
12	EC Declaration of Conformity	18

---

**Rennsteig Tools, Inc.**  
411 Hackensack Avenue,  
Suite 200  
Hackensack, NJ 07601-6331

Phone.: 330-315-3044  
Fax: 330-319-8135  
Email [info@rennsteig.us](mailto:info@rennsteig.us)

[www.rennsteig.us](http://www.rennsteig.us)

## 1 Intended use

The crimping tools are designed exclusively for use with die sets that are either distributed by RENNSTEIG or which RENNSTEIG has declared as being compatible.

The tools and the die sets must be used solely for the purpose as envisaged by RENNSTEIG. The tool is not intended for use in different or more specialised applications.

Any work performed with this tool that is not in line with its intended use can cause damage to the crimp tool, its accessories and the crimp contacts.

RENNSTEIG accepts no liability for losses resulting from

- the use of unsuitable crimping tools or crimping tools from other manufacturers;
- or
- the use of the tool in applications that are outside the scope of the tool's intended use.

Using the tool "as intended" also implies following the Operating Manual, performing inspections and maintenance work as instructed and compliance with all applicable safety provisions in their latest published version.

---

## 2 General safety instructions

Icons are used to mark sections of text as described below. Ensure you follow these instructions and take especial care in such situations. Also provide other users and technicians with a full set of health and safety instructions!



### **WARNING!**

This section warns the reader about a potentially dangerous situation that can lead to death or serious physical injury.



### **CAUTION!**

This section cautions the reader about a potentially dangerous situation that can lead to minor or moderate physical injury and/or damage to property.



### **Please note!**

The information in this section is of particular relevance to the description of a function or an operating procedure.

**Read this Operating Manual carefully!**  
**Follow all safety instructions as provided!**  
**Ensure compliance with national safety standards!**



**WARNING!**

**Read and follow all safety instructions and guidelines!**

Any failure to follow the safety instructions and guidelines as given can cause electrical shock, fire and/or serious injury.

Accordingly: Ensure that you retain all safety instructions and guidelines for future use and always include these when passing the equipment on to others.



**WARNING!**

**Danger of injury from airborne fragments!**

If the tool is used incorrectly, or if worn or damaged die sets and crimping tools are used, the operator risks injury from airborne fragments.

Accordingly:

- Crimping tools must be used solely by qualified personnel.
- Maintenance must be performed at the required intervals.
- Before each use, inspect the crimping tools and die sets for cracks and other signs of wear.
- Crimping tools and die sets with material flaws or other signs of wear must be taken out of service immediately and no longer used.
- Only use crimping tools and die sets if they are in perfect working order.
- If crimping tools or die sets have been used incorrectly, they must be removed from service and inspected by an authorised service centre.



**CAUTION!**

**Damage to/malfunctioning of the crimping tool and die set as a result of improper handling!**

Accordingly:

- Do not continue to use worn crimping tools – replace them immediately.
- For transportation and storage, use the carrying case and store the crimping tools and die sets in a dry place.
- Ensure all damage is inspected without delay by an authorised service centre.
- Observe the safety instructions for detergents and corrosion protection agents used.



**Please note!**

For working and installation instructions for crimp contacts, consult the documents as supplied by the manufacturer.





### 3 Terminology used

V	Volt	Ah	Amp-hour	∅	Diameter
A	Ampere	db(A)	Decibel (sound pressure)	h	Hour
Hz	Hertz	bar	Bar	min	Minute
W	Watt	°C	Degrees Celsius	s	Second
kW	Kilowatt	kN	Kilonewton	m/s <sup>2</sup>	Metres per second squared (acceleration)
g	Gram	AC	Alternating current	No.	Number
kg	Kilogram	DC	Direct current		
Bj	Year of manu- facture	F	Force		

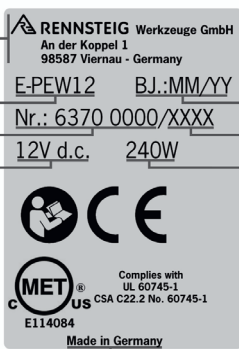
### 4 Symbols used on the equipment and rating plate details

Symbol	Meaning
	Maintenance sticker, with date of next service. Located in the battery compartment. To read the sticker, pull out the battery.

Rating plate details																	
	<table border="1"> <tbody> <tr> <td>1</td> <td>Manufacturer logo with address</td> </tr> <tr> <td>2</td> <td>Model designation for the tool</td> </tr> <tr> <td>3</td> <td>Article no.</td> </tr> <tr> <td>4</td> <td>Permitted voltage range in volts</td> </tr> <tr> <td>5</td> <td>Country of manufacture</td> </tr> <tr> <td>6</td> <td>Power consumption</td> </tr> <tr> <td>7</td> <td>Year of manufacture</td> </tr> <tr> <td>8</td> <td>Serial no.</td> </tr> </tbody> </table>	1	Manufacturer logo with address	2	Model designation for the tool	3	Article no.	4	Permitted voltage range in volts	5	Country of manufacture	6	Power consumption	7	Year of manufacture	8	Serial no.
1	Manufacturer logo with address																
2	Model designation for the tool																
3	Article no.																
4	Permitted voltage range in volts																
5	Country of manufacture																
6	Power consumption																
7	Year of manufacture																
8	Serial no.																

Explanation of possible rating plate icons used			
	Certification mark, Canada and USA		CE mark – product security in Europe
	Certification mark, Russia		
	Certification mark, Australia		Read the Operating Manual

## 5 Scope of delivery

The standard scope of delivery includes:

- eForce® - Battery Powered Crimping Tool, incl. Operating Manual
- Charger, incl. operating instructions
- With one (6370 0300 1 RT) or two (6370 0300 1-2 RT) Li-Ion Batteries (Milwaukee M12)
- Safety instructions
- Carrying case

Information about other accessories – such as die sets, positioning guides (locators), wire stops, etc. – can be obtained online at [www.rennsteig.us](http://www.rennsteig.us) online or scan QR code.



## 6 Technical specifications

Rated voltage / battery	12 V DC (lithium-ion) / 1.5 Ah / 3.0 Ah
Power consumption	240 W
Height	Approx. 142 mm
Length	Approx. 274 mm with 1.5 Ah battery; approx. 300 mm with 3.0 Ah battery
Width	Approx. 50 mm
Net weight	Approx. 2.0 kg (with 1.5 Ah battery)
Crimping area	Conductor inner cross-section: 0.08 mm <sup>2</sup> to 50 mm <sup>2</sup>
Max. sound power level	83 db(A) (measurement uncertainty 3 db(A))
Sound pressure level at operator ear	70 db(A) (measurement uncertainty 3 db(A))
Vibration level	<2.5 m/s <sup>2</sup> (measurement uncertainty 1.5 m/s <sup>2</sup> )
Protection class	IP20
Operating temperature range	-10 °C to +50 °C

The vibration emission figure stated has been measured using a standard test procedure and can be utilised when making comparisons with other equipment.

The figure can also be used for an initial estimation of exposure levels.

**Attention: During actual use of the equipment, the vibration emission figure can differ to the value stated, depending on the specific application for which the equipment is being used. Depending on the actual operations conditions experience (exposure while working), it may be necessary to draw up safety precautions for operating personnel.**

For information about charger operation and functionality, please consult the operating instructions enclosed for the charger.

## 7 Brief description of the crimping tool

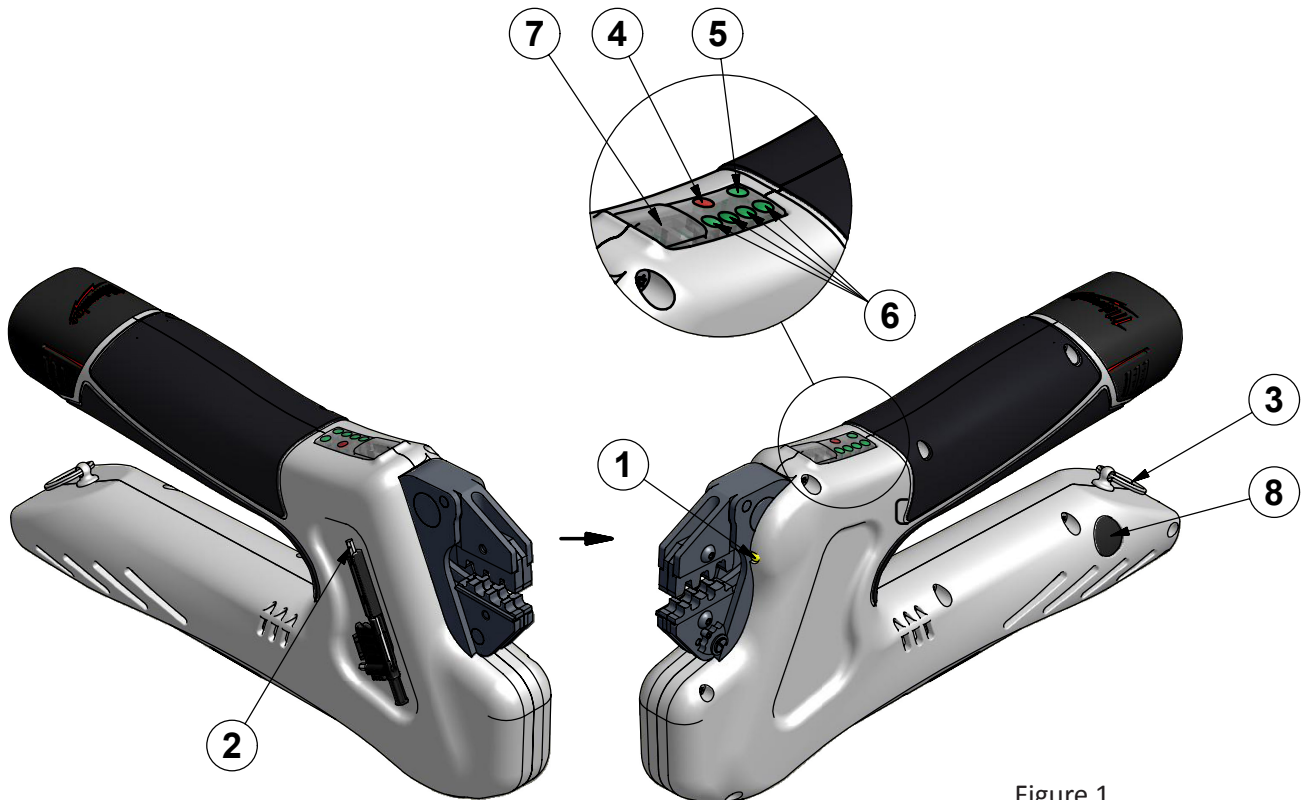

Figure 1

### LED (1)

The LED (1) illuminates the crimp position. This LED lights up when the crimping tool is ready for use.

### Allen key (2)

An Allen key (2) is required for changing the die sets. This key is clipped to the crimping tool. The key (2) is removed for use and then pressed back into the clip holder.

### Key ring (3)

The crimping tool is equipped with a key ring (3) to which a carry strap or catch mechanism can be attached.

## 7.1 Operation

Press and hold the Start button (7) to close the jaws of the crimping tool.  
If the Start button (7) is released, the tool halts immediately at its current position.  
When the tool reaches its final position and finishes crimping, the jaws automatically open again.

---

## 7.2 Reset button

Pressing the Reset button (8) cancels the crimping operation and switches off the crimping tool.

### 7.2.1 Cancelling a crimping operation

- The crimping operation can be interrupted by releasing the Start button (7). This will halt the tool at its current position.
- To re-open the tool, briefly press the Reset button (8).
- The tool returns to its starting position.

### 7.2.2 Switching off the crimping tool

- Press and hold the Reset button (8).
  - All LEDs go out and the crimping tool switches itself off.
- or
- The tool switches itself off automatically if not used for approx. 5 min.
- 

## 7.3 Battery

**Please note!**

The batteries are not charged at the factory.  
Accordingly: Charge the battery before first using the tool!

**Please note!**

Specific temperatures apply to charging performance and battery storage.  
Accordingly: Ensure you follow the charger's operating instructions!



### Removing the battery (Figure 2)

Depress (1) both unlocking buttons (A) and then pull out the battery (2).

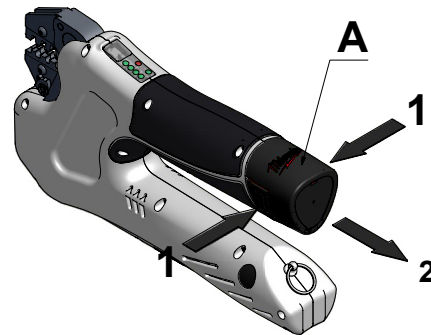

Figure 2

### Inserting the battery (Figure 3)

Push the battery into the tool as shown until it locks into place.

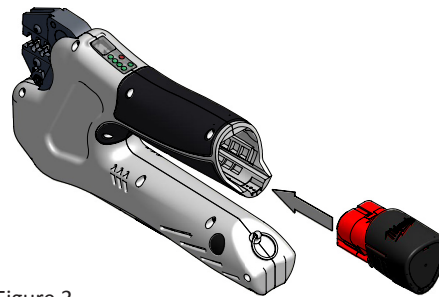

Figure 3

### Battery status indicator

The 4 green LEDs (6) show the battery's charge level. The number of LEDs illuminated indicates the charge level. If the LED (5) flashes, the battery is empty and crimping is not possible.

## 7.4 eForce® battery usage



#### Please note!

The eForce® - Battery Powered Crimping Tool must be powered by a 12 V lithium-ion rechargeable battery.

### Behaviour of the crimping tool after prolonged non-use or on battery change

The crimping tool switches itself off if it is not used for a while or if its battery is removed. No LED is illuminated. To switch on the crimping tool, press the Start button (1).

### Behaviour of the crimping tool when battery is empty

If the green LED (5) flashes, the battery is empty and crimping is not possible. The battery must be recharged.

## 8 First use and operation



### WARNING !

Do not work with the crimping tool at live wires!  
Always verify the workpiece is not energized.



### CAUTION!

Finger crush hazard when operating the tool without crimping die sets!  
(Figure 4)



### Please note!

The crimping tool is not intended as a replacement for a stationary crimping machine.

Without a die set inserted, the operator's fingers can slip between the jaws of the tool. Starting the tool would then crush the operator's fingers.

Accordingly: Never operate the tool without a die set.  
Keep fingers out of the jaws of the tool.

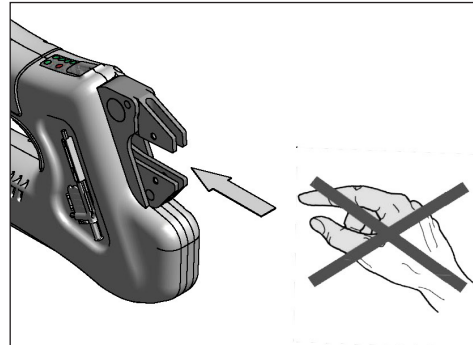

Figure 4



### CAUTION!

Risk of damaging the crimping tool and the die sets!

The crimping tool and the die sets can be damaged by

- Assembling non-matched upper and lower die set parts together; and by
- Failing to assemble the die set parts properly.

Accordingly:

- Ensure that you orient the die set parts properly when fitting them
- To prevent damaging on the tool it needs to be used as shown on Figure 4a

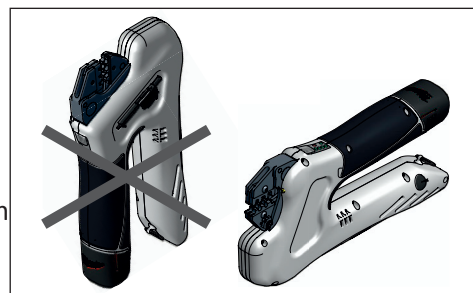

Figure 4a

### 8.1 Preparing the eForce®

#### 8.1.1 Fitting die sets without additional positioning guides, e.g. for insulated/non-insulated cable connectors, through and coax connectors, wire-end sleeves, RJ plugs, etc. (Figure 5, 6)

1. Select the crimping die set as appropriate (e.g. insulated connectors or wire-end sleeves).
2. Push the closed crimping die set – as shown in Figure 5 – into the socket on the die until the lower piece of the die set can be loosely screwed into place.
3. Press the Start button on the crimping tool briefly to close it so the upper part of the die set can be screwed into place (figure 6).
4. Now tighten both screws.

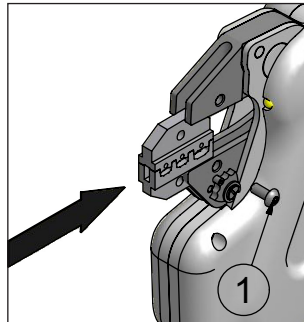

Figure 5

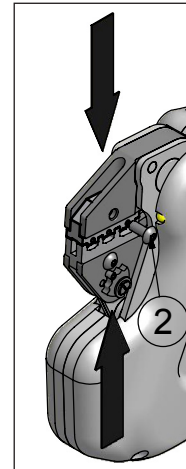

Figure 6

## 8.1.2 Fitting die sets with additional positioning guides

### 8.1.2.1 Examples: non-insulated open plug connectors, D-sub plugs, etc. (Figure 7)

A positioning guide can be used to position the connectors. For use without a positioning guide, assemble as shown in Section 8.1.1.

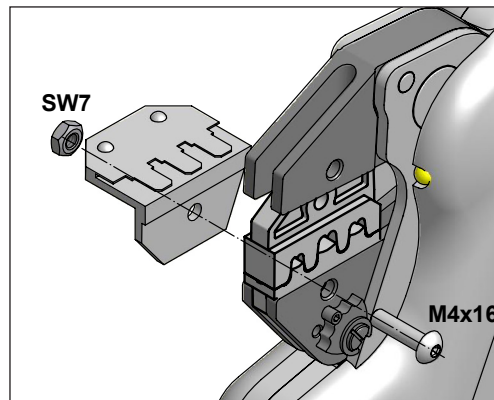

Figure 7

1. Select the crimping die set as appropriate (e.g. non-insulated blade connectors, D-sub plugs, etc.).
2. Push the closed crimping die set – as shown in Figure 5 – into the socket on the die until the lower piece of the die set can be loosely screwed into place using the M4x16 screw.
3. Press the Start button on the crimping tool briefly to close it so the upper part of the die set can be screwed into place (figure 6).
4. Now tighten both screws.
5. Push the positioning guide onto the M4x16 screw as shown in Figure 7 and secure using the nut (SW 7).

### 8.1.2.2 Example for rotated contacts (Figure 8, 9)

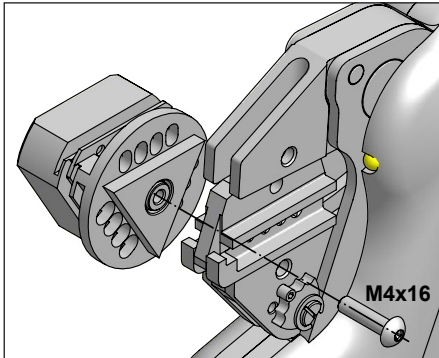

Figure 8

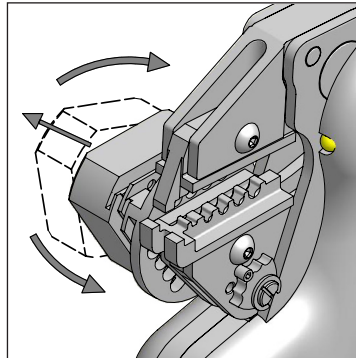

Figure 9

A positioning guide can be used to position the connectors. For use without a positioning guide, assemble as shown in Section 8.1.1.

1. Select the crimping die set as appropriate.
2. Push the closed crimping die set – as shown in Figure 5 – into the socket on the die until the lower piece of the die can be loosely screwed into place using the M4x16 screw.
3. Press the Start button on the crimping tool briefly to close it so the upper part of the die set can be screwed into place (figure 6).
4. Now tighten both screws.
5. Place the positioning guide onto the M4x16 screw as shown in Figure 8 and secure using the thread contained in the locator. (Figure 9)

## 8.2 LED display meanings

LED display	Status/cause	Action
No LEDs illuminated	The tool is switched off.	Press the Start button (see Section 7.4).
Green LED (5) is illuminated	The tool is ready for use.	
Green LED (5) not illuminated (jaws opening)	The crimping tool is returning automatically to its starting position.	
Green LED (5) flashes	Battery charge level insufficient.	Recharge or replace the battery.
Green LEDs (6)	Battery charge level indicator	

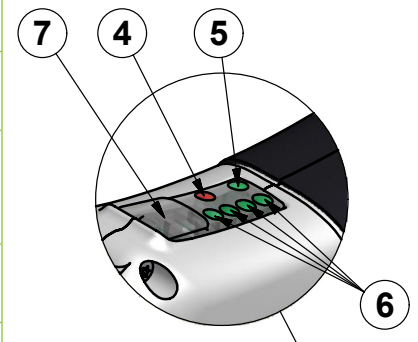

LED display	Status/cause	Action
Red LED (4) is flashing	Tool outside operating temperature range	The tool's operating temperature range is -10 °C to +50 °C: if the red LED is flashing, the tool must be moved to a warmer/ cooler environment.
Red LED (4) is illuminated	The crimping tool has not returned to its starting position after switching off.	Press the Reset button (8). The crimping tool returns to its starting position.
Red LED (4) is illuminated	An excessive level of power draw has been detected – overcurrent protection	Check the combination of die sets/crimp contacts. Clean crimping tool as required. If the fault persists, return the crimping tool to a service centre.
Red (4) and green (5) LEDs are flashing alternately	Maintenance interval of 25,000 operations reached.	Return the crimping tool for service.
Red LED (4) illuminated and all other LEDs flashing	Tool malfunction	Return the crimping tool to a service centre.

### 8.3 Crimping



**CAUTION!**

There is a risk of crush injuries to fingers and hands!  
Accordingly: During crimping, keep all parts of the body and other objects away from the die set jaws.

#### 8.3.1 Die sets for insulated/non-insulated cable connectors, through and coax connectors, wire-end sleeves, RJ plugs (Figure 10)

1. Check that the connector parameters match those for the crimping die set.
2. Insert the connector into the die set as appropriate for its cross-section.
3. Press the Start button briefly, so as to close the die set far enough to hold the connector straight.
4. Insert a stripped cable into the connector.
5. Press the Start button and keep it pressed until crimping is complete.
6. After crimping has finished, remove the connector from the crimping tool.

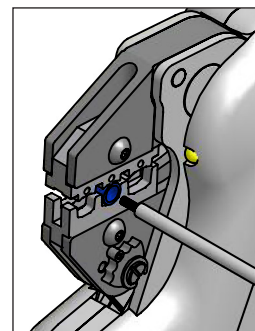

Figure 10

### 8.3.2 Die sets for non-insulated open plug connectors, D-sub plugs (Figure 11)

1. Check that the connector parameters match those for the crimping die set.
2. Insert the connector into the die set and positioning guide as appropriate for its cross-section.
3. Insert a stripped cable into the connector.
4. Press the Start button and keep it pressed until crimping is complete.
5. After crimping has finished, remove the connector from the crimping tool.

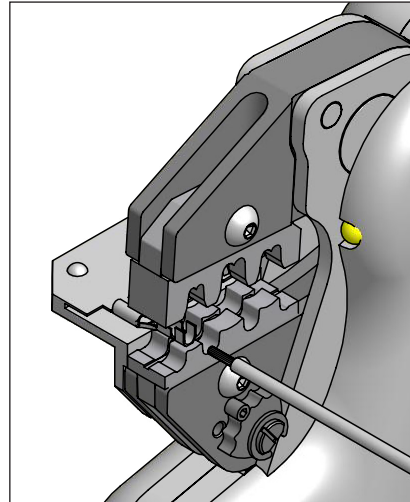

Figure 11

### 8.3.3 Die sets for rotated contacts (Figure 12, 13)

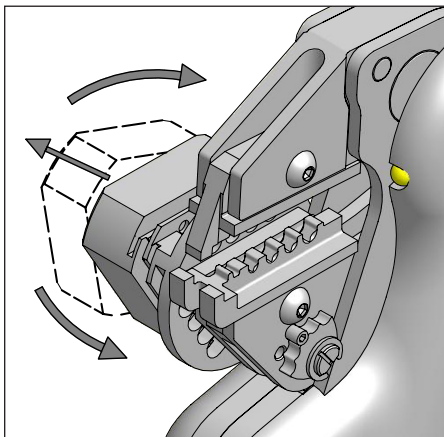

Figure 12

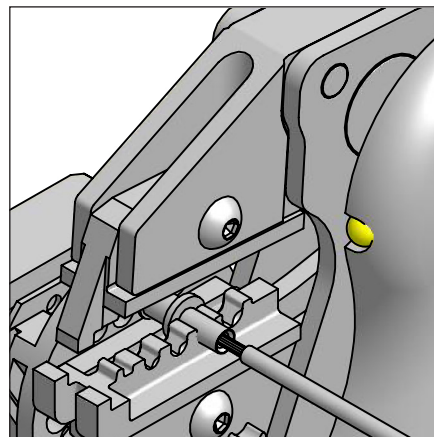



Figure 13

1. Check that the connector parameters match those for the crimping die set.
2. If required, pull out the positioning guide and rotate it in order to position it correctly. (Figure 12)
3. Insert the connector into the die set and positioning guide as appropriate for its cross-section.
4. Insert a stripped cable into the connector.
5. Press the Start button and keep it pressed until crimping is complete.
6. After crimping has finished, remove the connector from the crimping tool.

**9 Cleaning, maintenance and repair**

	<p><b>CAUTION!</b>                  Danger of injury during cleaning or repair by accidentally pressing buttons on the tool!                  Accordingly: Follow safety instructions during cleaning, maintenance or repair work and always remove the battery before hand.</p>
---	--

	<p><b>Maintenance intervals</b>                  All maintenance and repair work must always be performed by RENNSTEIG or by a service center authorised by RENNSTEIG. For Sending in an Battery Powered Crimping Tool for maintenance or repair please contact us (<a href="https://eforce.rennsteig.us">https://eforce.rennsteig.us</a>) or our authorized US service partner: <a href="https://goo.gl/t4RafE">https://goo.gl/t4RafE</a> (FiberFin, Inc.)</p>
---	---

**Maintenance intervals**

All maintenance and repair work must always be performed by RENNSTEIG or by a service centre authorised by RENNSTEIG.

**Cycles display within a service interval**

With the crimping tool switched off, you can check the number of cycles remaining before the next service by completing the steps as given below:

- Press and hold the Reset button (8) (Fig.1).
- Then press and hold the Start button (7) (fig.1).
- As soon as LED (4) and (5) (fig.1) are flashing simultaneously, release both buttons. The mode “service display” is active.
- The four green LED lights (6) (fig.1) show the remaining cycle time (crimp operations) until next service is due (see table below).
- To exit service display mode, press the Reset key (8) or the Start key (7) (Figure 1).

Display (LED 6) Figure 1	Number of cycles remaining
All 4 battery LEDs illuminated	25,000 to 20,000 crimp operations
Bottom 3 battery LEDs illuminated	20,000 to 15,000 crimp operations
Bottom 2 battery LEDs illuminated	15,000 to 10,000 crimp operations
Bottom 1 battery LED illuminated	10,000 to 5,000 crimp operations
No battery LEDs illuminated	5,000 to 500 crimp operations
All 4 battery LEDs flashing	500 to 0 crimp operations

	<p><b>Please note!</b>                  The next service due is specified by an inspection label placed on the crimping tool. This service must be performed at least once every 2 years or at the point in time indicated by the LED display (see Section 8.2, “LED display meanings”).</p>
---	--

Carry out maintenance and repair work regularly (before use, at the start of the working day) or if the tool becomes soiled. (Figure 14)

Inspect the tool for visible exterior damage, material faults and other signs of wear. If you find defects, discontinue using the tool and send it in for repairs.

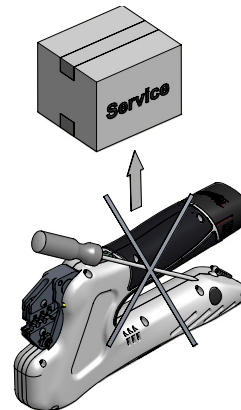

Figure 14

### Setting the crimp height (Figure 15)

If the results of crimping do not meet the specifications set by the connector manufacturer (crimp height, extraction force), this may have the following causes:

**Normal usage of the tool has resulted in wear:**  
the crimping force can be recalibrated.

**Crimping die set worn:**  
to avoid damage, the crimping die set must be replaced.



**Please note!**

The crimp height should be checked regularly by qualified personnel from quality control and recalibrated as required using the method described below.



**CAUTION!**

To avoid damage to the tool and crimping die sets, please ensure that the adjusting disc is only ever rotated step-wise by a half-notch each time. This is achieved by repositioning the screw (A) in the next free threaded hole to secure the adjusting disc in place.

1. Disengage screw (A).
2. Turn the adjusting disc (B) a half-notch.
  - Turn clockwise --> results in a higher crimping force and a reduced crimping height.
  - Turn anti-clockwise --> results in a lower crimping force and therefore an increased crimping height.
3. Insert screw (A) into the other threaded hole and tighten.

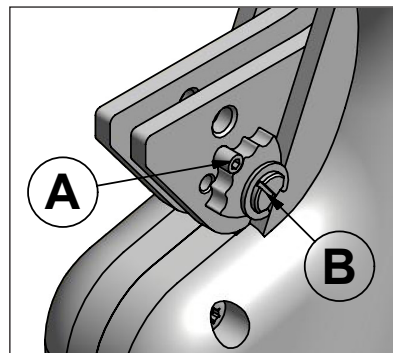
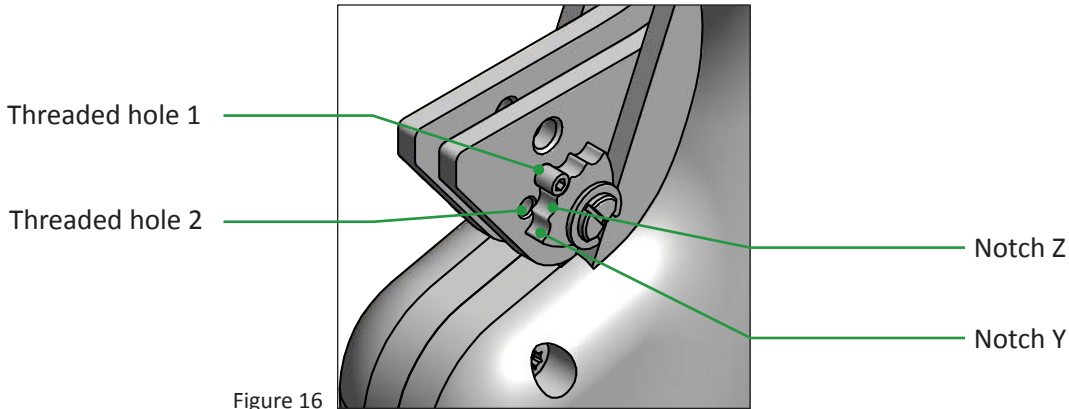

Figure 15



**Tool setting example:**

1. Remove screw (A) from the threaded hole (1).
2. Turn the adjusting disc a half-notch.
  - Notch (Y) over threaded hole (2) = rotate clockwise
  - Notch (Z) over threaded hole (2) = rotate anti-clockwise
3. Insert screw (A) into threaded hole (2) and tighten.

In the state as shown, no other notch-hole combinations are permitted, since the change to the crimping dimensions and/or force would be much too great. This could result in damage to the tool and the crimping die sets.

**10 Disposal**

Do not dispose of the tool or its accessories in household waste.

For disposal of the battery and the charger, please follow the information given in the charger's operating instructions.

RENNSTEIG recommends using a licensed waste management company to handle disposal. Alternatively, the tool and its accessories can be returned to RENNSTEIG or a service centre.

**11 Warranty**

All RENNSTEIG crimping tools are covered by the full German statutory product warranty of 24 months or 4 maintenance cycles (whichever occurs first). The warranty period always commences when supplied; in cases of doubt, proof of purchase documentation must be shown.

Within the guarantee period, the product warranty covers the rectification of all damage or faults affecting the tool, where such damage or faults are traceable to material or manufacturing defects.

Items not covered by the warranty:

- Damage caused by improper use or inadequate maintenance.
- Damage caused by the application of products that Rennsteig has not approved for use with its crimping tools.
- Damage caused by the crimping of unsuitable cables or connectors.

RENNSTEIG offers no product warranty on replacement parts.

While services rendered under the terms of the warranty are free of charge, the equipment owner must bear the costs of carriage in both directions.

Complaints will be recognised only if the equipment is returned in its fully-assembled state to Rennsteig or an authorised service centre.

Any repair or exchange of the equipment conducted under the terms of the warranty does not extend the warranty period. Repair or exchange always involves the supply of as-new parts, whose function matches that of the old parts. All defective – and therefore replaced – parts are the property of the manufacturer.

---

## 12 EC Declaration of Conformity

In accordance with EU Directives 2004/108/EC; 2006/42/EC

We hereby declare that the

### **eForce® - Battery Powered Crimping Tool**

conforms to the relevant general safety and health regulations in terms of its design and type, and in terms of the model as placed by us on the commercial market. The validity of this Declaration is rendered void if the product is not used as intended or if it is modified in ways that we have not approved beforehand.

Applicable standards:

EN 55014-1; EN 55014-2; EN 60745-1; EN ISO 12100

Viernau, 04/23/2013



---

Sascha Zmiskol  
Managing Director

**Rennsteig Werkzeuge GmbH**  
An der Koppel 1  
98547 Viernau  
Germany

Tel.: +49 (0) 36847 / 4 41-0  
Fax: +49 (0) 36847 / 4 41-14  
Email: [info@rennsteig.com](mailto:info@rennsteig.com)  
Web: [www.rennsteig.com](http://www.rennsteig.com)