

Figure 1.1. Top View of AHV12V1KV5MAW



Figure 1.2. Side View



Figure 1.3. Side View

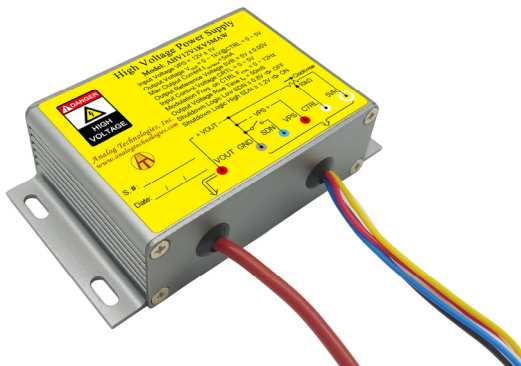

Figure 1.4. Side View

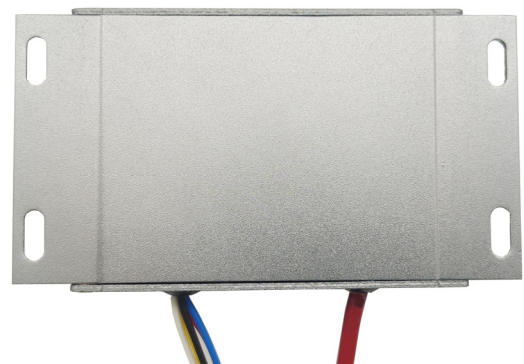

Figure 1.5. Bottom View

FEATURES

- Input Power Voltage: 12V ± 1V
- Input Current Range: 100mA to 600mA
- Output Voltage: 0 to 1kV@CTRL = 0 to 5V
- Max. Output Current: 5mA
- Reference Voltage: 5V ± 0.05V
- Input Control Voltage: 0 to 5V
- Full Span Modulation on Output Voltage
- Electronic Shutdown Control
- OEM customizable Available

APPLICATIONS

This power module, AHV12V1KV5MAW, is designed for achieving DC-DC conversion from low voltage to high voltage as a power supply source which is widely used in scientific research and other fields including:

- X-ray Machine
- Spectral Analysis
- Nondestructive Inspection
- Semiconductor Manufacturing Equipment
- CRT Monitor Test
- Particle Accelerator
- Capillary Electrophoresis
- Particles Injection
- Semiconductor Technology
- Physical Vapor Phase Deposition
- Radio Frequency Amplification
- Electrospinning Preparation of Nanofiber
- Glass / Fabric Coating
- DC Reactive Magnetron Sputtering
- Cyclotron Accelerator

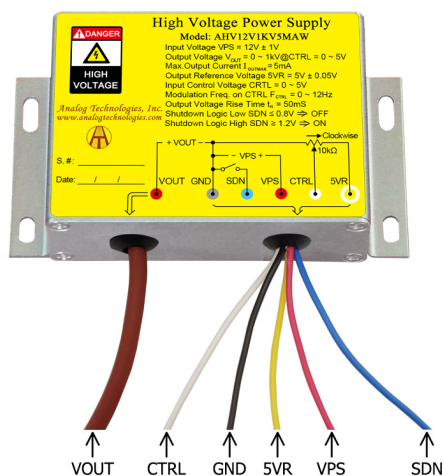

Figure 2. The Connecting Lead Wires of AHV12V1KV5MAW

Table 1. Pin Names, Colors, Functions and Specifications.

No.	Name	Color	Type	Description	Min.	Typ.	Max.
1	SDN	Blue	Digital input	Shutdown logic low	0V		0.8V
				Shutdown logic high	1.2V		5V
2	5VR	Yellow	Analog output	Reference voltage		5V	
3	CTRL	White	Analog input	Regulation	0V		5V
4	VPS	Red	Power input	Input voltage		12V	
5	GND	Black	Ground for analog, digital and power signals.	Ground electrode		0V	
6	VOUT	Brown	Power output	Output high voltage	0V		1kV



DESCRIPTION

Figure 2 shows the connecting wires of AHV12V1KV5MAW, of which their detail information given in Table 1. The output voltage can be set to a constant value by connecting the CTRL port to the central tap of a POT (Potentiometer) or modulated by an AC signal ranging from 0V to 5V corresponding to 0V to 1kV proportionally at the output VOUT port as shown in Figure 3 and Figure 4 respectively.

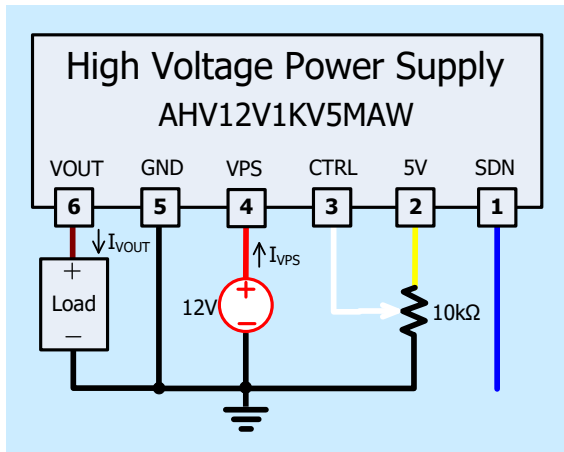

Figure 3. Setting Output to be a Constant Voltage

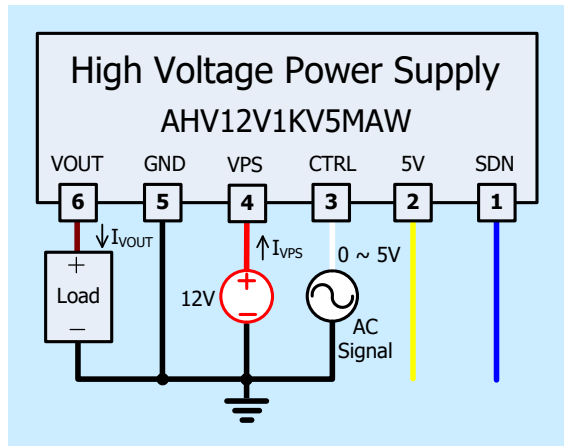

Figure 4. Modulating Output by an AC Signal Source

Please note that the modulation signal must have a low frequency $\leq 12\text{Hz}$ and the value range must be $0\text{V} \leq V_{CTRL} \leq 5\text{V}$. The equivalent input circuit for the CTRL is shown in Figure 5.

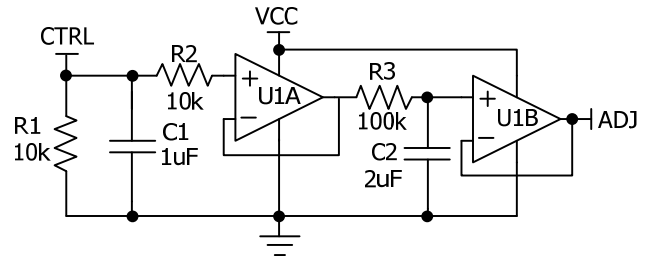

Figure 5. The Equivalent Circuit for CTRL Port

To shutdown AHV12V1KV5MAW, pull down SDN pin to $< 0.8\text{V}$; to turn it on, leave SDN pin unconnected or pull it $> 1.2\text{V}$. The maximum voltage allowed on the SDN pin is 5V. The equivalent circuit for SDN port is shown in Figure 6.

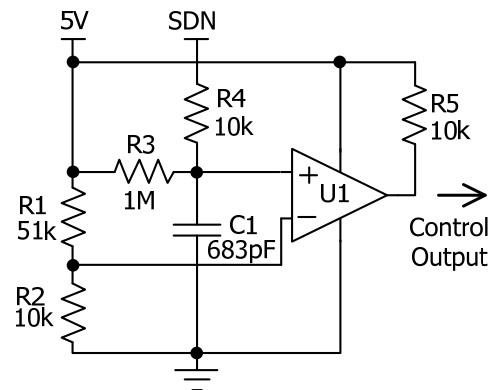

Figure 6. The Equivalent Circuit for SDN Port

USING AHV12V1KV5MAW

This high voltage power supply must be mounted tightly onto a metal plate, ideally, thus expanding its heating sinking capacity of the metal enclosure. Sufficient ventilation must be provided to keep the power supply surface temperature under 55°C .

SAFETY PRECAUTIONS

Although AHV12V1KV5MAW high voltage power supply comes with an over current protection circuit, a short circuit at the output should always be avoided. Make sure the high voltage wire for connecting VOUT node has sufficient insulation capability with its surrounding objects.



SPECIFICATIONS

Table 2. Characteristics. T_A = 25°C, unless otherwise noted.

Parameter	Symbol	Test Conditions	Min.	Typ.	Max.	Unit/Note	
Input Power Voltage	V _{VPS}		11	12	13	V	
Input Power Quiescent Current	I _{VPS_QC}	I _{VOUT} = 0mA	100	150	200	mA	
Input Power Current at Full Load	I _{VPS_FL}	I _{VOUT} = 5.0mA	550	600	650	mA	
Input Power Current at Shutdown	I _{VPS_SHDN}	T _A = -10°C ~ 55°C		13		mA	
Modulation Voltage Range Frequency on CTRL	f _{CTRL}		0		12	Hz	
Shutdown Port Current	I _{SDNL}	0 ≤ V _{SDNL} < 0.8V	4		4.8	μA	
	I _{SDNH}	1.2V < V _{SDNL} < 5V	0		3.6	μA	
Shutdown Voltage Logic Low	V _{SDNL}		0		0.8	V	
Shutdown Voltage Logic High	V _{SDNH}		1.2		5	V	
Output Voltage	V _{VOUT}	I _{VOUT} = 0 ~ 5.0mA	0		1000	V	
Output Current Range	I _{VOUTMAX}	V _{VPS} = 11V ~ 13V	0		5.0	mA	
Reference Voltage Output Range	V _{5VR}	T _A = -10°C ~ 55°C I _{5VR} ≤ 1mA	4.98	5	5.02	V	
Reference Current Output Range	I _{5VR}	T _A = -10°C ~ 55°C V _{5VR} = 0 ~ 5V	0		1	mA	
Output Load Range			200		∞	kΩ	
Output Voltage Ripple	V _{VOUT_RP}	Bandwidth = 1MHz R _{LOAD} = 200 kΩ	≤0.5			V _{P-P}	
Output Voltage Temperature Coefficient	TCV _{VOUT}	V _{VPS} = 12V V _{CTRL} = V _{5VR} = 5V V _{VOUT} = 1kV I _{VOUT} = 5mA T _A = -10°C ~ 55°C		≤0.01		%/°C	
Output Voltage Range v.s. Temperature	V _{VOUT(T)}	V _{VPS} = 12V V _{CTRL} = V _{5VR} = 5V V _{VOUT} = 1kV I _{VOUT} = 5mA T _A = -10°C ~ 55°C	0.99V _{VOUT}	V _{VOUT}	1.01V _{VOUT}	V	
Output Voltage Drift	Short Term Drift	$\frac{ \Delta V_{VOUT} }{V_{VOUT}}$ Δt (min)	V _{VPS} = 12V V _{CTRL} = V _{5VR} = 5V V _{VOUT} = 1kV I _{VOUT} = 5mA T _A = -10°C ~ 55°C			≤0.5	%/min
	Long Term Drift	$\frac{ \Delta V_{VOUT} }{V_{VOUT}}$ Δt (h)				≤1	%/h
Output Voltage Rise Time	t _r	V _{VOUT} (t ₁) = 100V V _{VOUT} (t ₂) = 900V R _{Load} = 200 kΩ		50		ms	



Parameter	Symbol	Test Conditions	Min.	Typ.	Max.	Unit/Note
Output Voltage Fall Time	t_f	$V_{VOUT}(t_2) = 900V$ $V_{VOUT}(t_3) = 100V$ $R_{Load} = 200\ k\Omega$		100		ms
Mean Time Between Failure	MTBF			1M		h
Instantaneous Short Circuit Current at the Output	I_{VOUT_SC}			≤ 500		mA
Load Regulation	$\frac{ \Delta V_{VOUT} }{V_{VOUT}}$ ΔI_{VOUT}	$V_{VOUT} = 1kV$ $I_{VOUT} = 5mA$		≤ 0.05		%/mA
Full Load Efficiency	η	$V_{VPS} = 12V$ $V_{VOUT} = 1kV$ $I_{VOUT} = 5mA$		≥ 70		%
Operating Temperature Range	T_{opr}		-10		55	°C
Storage Temperature Range	T_{stg}		-20		85	°C
External Dimensions			82×55×28			mm
			3.23×2.17×1.10			inch
Weight				210		g
				0.46		lbs
				7.4		Oz



TESTING DATA

Test conditions: $V_{VPS} = 12V$, $T_A = 15^\circ C$, $R_{LOAD} = 200k\Omega$

DC Testing

The measured output voltage, V_{VOUT} , corresponding to the control port input voltage, V_{CTRL} , is shown in Figure 7.

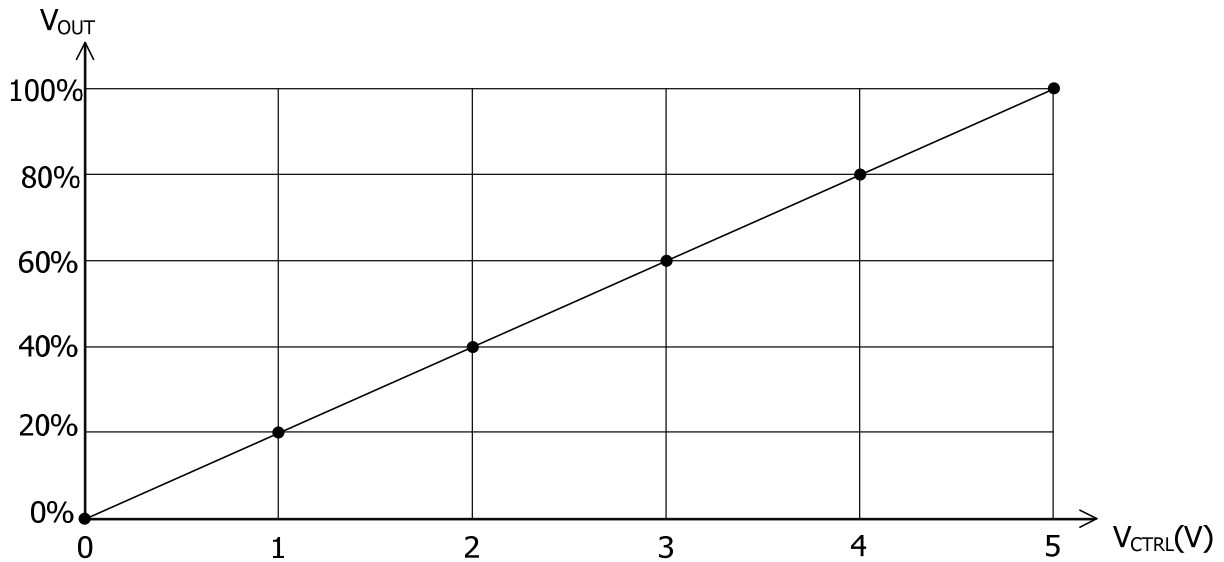

Figure 7. V_{CTRL} vs. V_{VOUT}

AC Testing

To test the analog modulation function, a triangle and sine-wave voltage signals are applied to the CTRL port as the input source signal respectively. Figure 8 and 9 show both the input signal and the output signal waveforms when using the triangle and sine-wave signals at the CTRL port respectively.

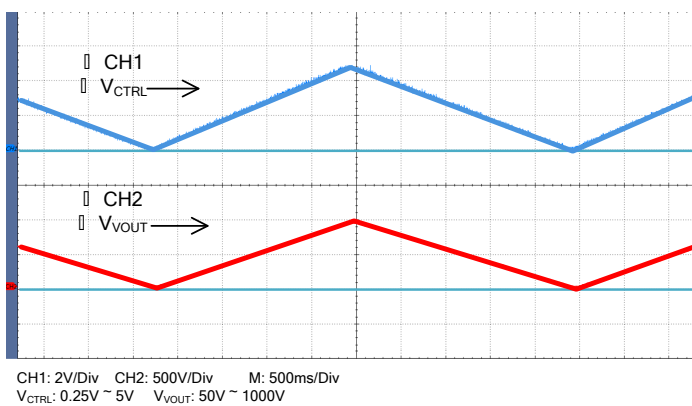

Figure 8. Input vs. Output Waveforms for Triangle Wave Control

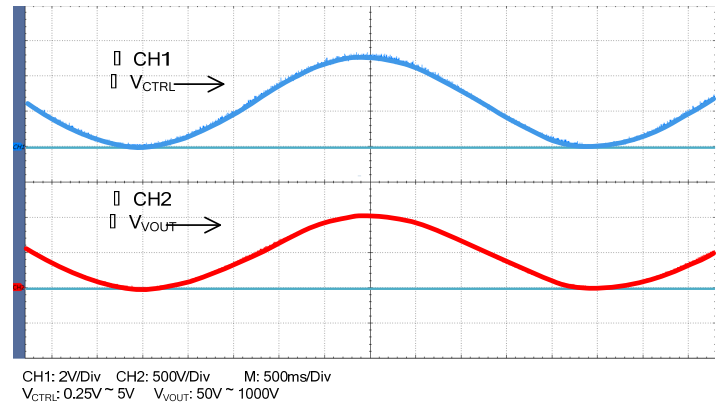

Figure 9. Input vs. Output Waveforms for Sine Wave Control



To test the rise and fall times at the output, a step function signal is applied to the CTRL port. The testing results are shown in Figure 10, Figure 11, and Figure 12. As shown in Figure 11 and Figure 12, a square wave of 0.25V ~ 5V, f = 0.10Hz, is applied to CTRL port, the output waveform fall time is measured to be about 100ms and the rise time is about 30ms. These two values are not the same, that is because on the rising trail, the power supply injects a current to the load; while on the falling trail, the best the power supply can do is to stop its output current and let the load resistor drain the output filtering capacitor to a lower voltage, and the draining current is much smaller than the injection current.

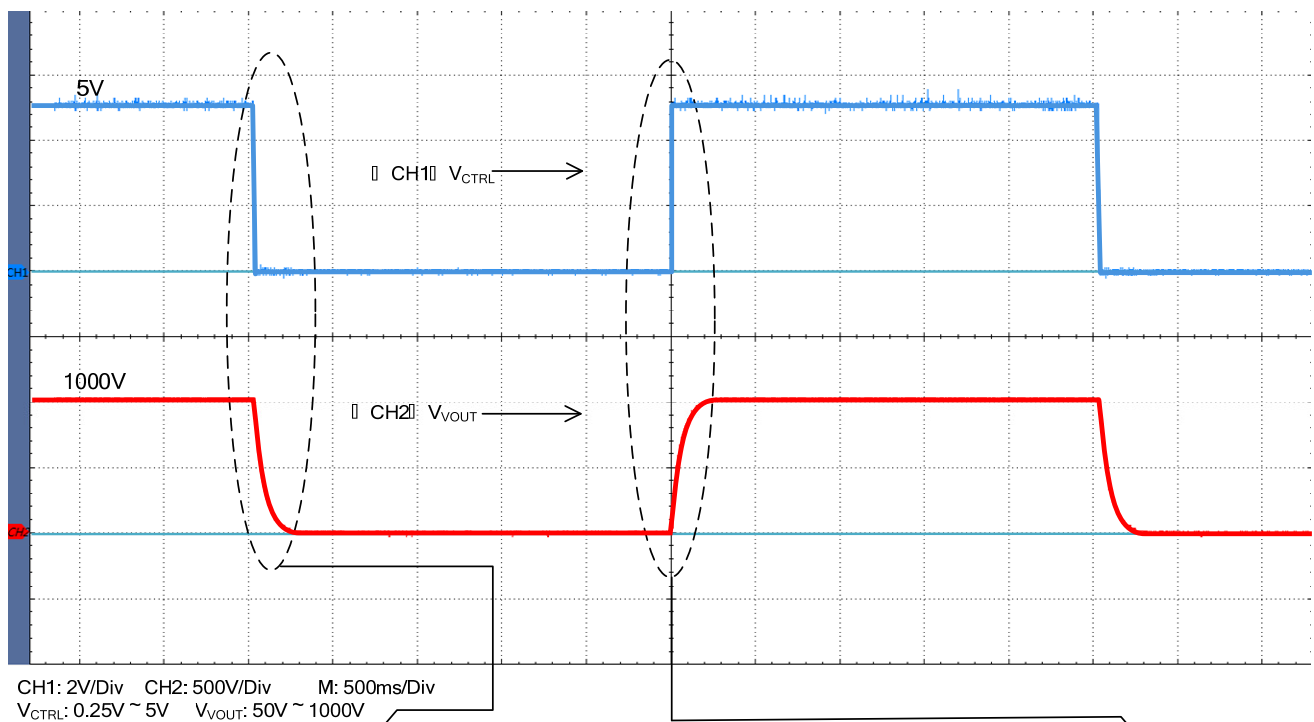

Figure 10. Input vs. Output Waveforms for Square Wave Control

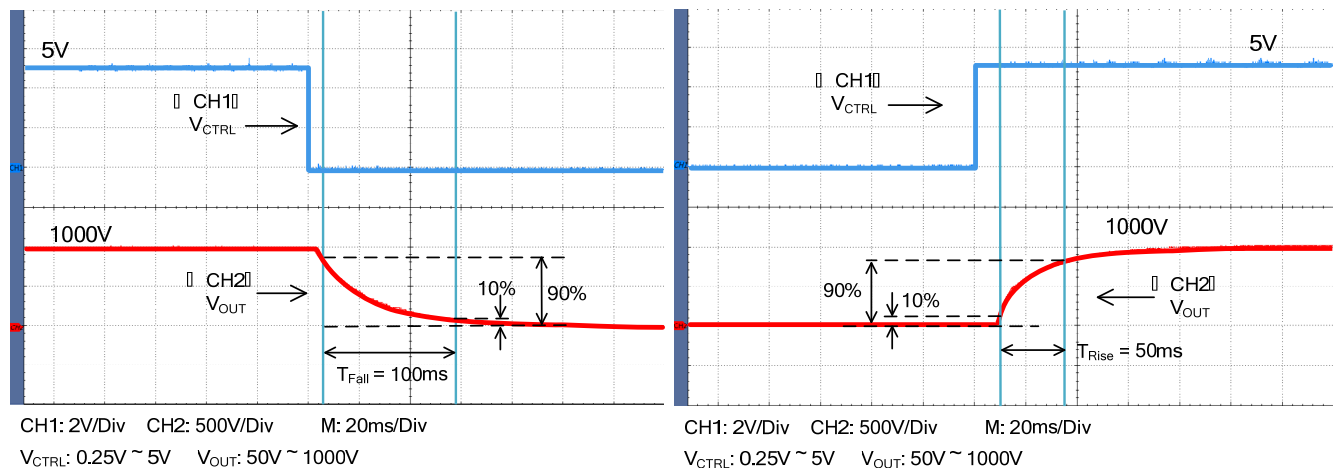
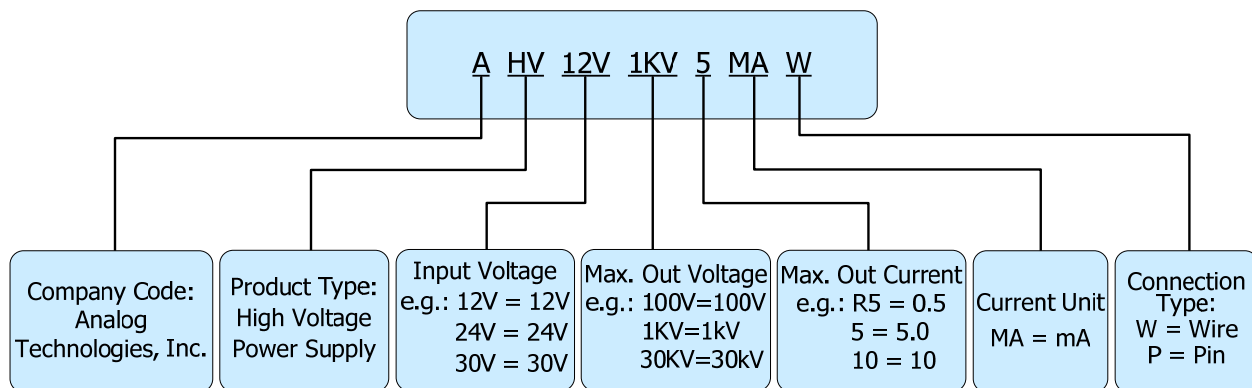

Figure 11. Falling Trail for Large Signal Response

Figure 12. Rising Trail for Large Signal Response



NAMING PRINCIPLE



Naming Principle of AHV12V1KV5MAW

RELATED PRODUCTS

Input Voltage: 12V, Input Control Voltage: 0 to 5V, Efficiency: 70%.

Part #	Output Voltage (V)	Output Current (mA)	Part #	Output Voltage (V)	Output Current (mA)
AHV12V500V1MAW	500	1	AHV12VN500V1MAW	-500	1
AHV12V500V2MAW	500	2	AHV12VN500V2MAW	-500	2
AHV12V500V3MAW	500	3	AHV12VN500V3MAW	-500	3
AHV12V500V4MAW	500	4	AHV12VN500V4MAW	-500	4
AHV12V500V5MAW	500	5	AHV12VN500V5MAW	-500	5
AHV12V500V6MAW	500	6	AHV12VN500V6MAW	-500	6
AHV12V500V7MAW	500	7	AHV12VN500V7MAW	-500	7
AHV12V500V8MAW	500	8	AHV12VN500V8MAW	-500	8
AHV12V500V9MAW	500	9	AHV12VN500V9MAW	-500	9
AHV12V500V10MAW	500	10	AHV12VN500V10MAW	-500	10
AHV12V500V20MAW	500	20	AHV12VN500V20MAW	-500	20
AHV12V500V30MAW	500	30	AHV12VN500V30MAW	-500	30
AHV12V500V40MAW	500	40	AHV12VN500V40MAW	-500	40
AHV12V600V30MAW	600	30	AHV12VN600V30MAW	-600	30
AHV12V1KV1MAW	1000	1	AHV12VN1KV1MAW	-1000	1
AHV12V1KV2MAW	1000	2	AHV12VN1KV2MAW	-1000	2
AHV12V1KV3MAW	1000	3	AHV12VN1KV3MAW	-1000	3



Part #	Output Voltage (V)	Output Current (mA)	Part #	Output Voltage (V)	Output Current (mA)
AHV12V1KV4MAW	1000	4	AHV12VN1KV4MAW	-1000	4
AHV12V1KV5MAW	1000	5	AHV12VN1KV5MAW	-1000	5
AHV12V1KV6MAW	1000	6	AHV12VN1KV6MAW	-1000	6
AHV12V1KV7MAW	1000	7	AHV12VN1KV7MAW	-1000	7
AHV12V1KV8MAW	1000	8	AHV12VN1KV8MAW	-1000	8
AHV12V1KV9MAW	1000	9	AHV12VN1KV9MAW	-1000	9
AHV12V1KV10MAW	1000	10	AHV12VN1KV10MAW	-1000	10
AHV12V1KV20MAW	1000	20	AHV12VN1KV20MAW	-1000	20
AHV12V1500V1MAW	1500	1	AHV12VN1500V1MAW	-1500	1
AHV12V1500V2MAW	1500	2	AHV12VN1500V2MAW	-1500	2
AHV12V1500V3MAW	1500	3	AHV12VN1500V3MAW	-1500	3
AHV12V1500V4MAW	1500	4	AHV12VN1500V4MAW	-1500	4
AHV12V1500V5MAW	1500	5	AHV12VN1500V5MAW	-1500	5
AHV12V1500V6MAW	1500	6	AHV12VN1500V6MAW	-1500	6
AHV12V1500V7MAW	1500	7	AHV12VN1500V7MAW	-1500	7
AHV12V1500V8MAW	1500	8	AHV12VN1500V8MAW	-1500	8
AHV12V1500V9MAW	1500	9	AHV12VN1500V9MAW	-1500	9
AHV12V1500V10MAW	1500	10	AHV12VN1500V10MAW	-1500	10
AHV12V2KV1MAW	2000	1	AHV12VN2KV1MAW	-2000	1
AHV12V2KV2MAW	2000	2	AHV12VN2KV2MAW	-2000	2
AHV12V2KV3MAW	2000	3	AHV12VN2KV3MAW	-2000	3
AHV12V2KV4MAW	2000	4	AHV12VN2KV4MAW	-2000	4
AHV12V2KV5MAW	2000	5	AHV12VN2KV5MAW	-2000	5
AHV12V2KV6MAW	2000	6	AHV12VN2KV6MAW	-2000	6
AHV12V2KV7MAW	2000	7	AHV12VN2KV7MAW	-2000	7
AHV12V2KV8MAW	2000	8	AHV12VN2KV8MAW	-2000	8
AHV12V2KV9MAW	2000	9	AHV12VN2KV9MAW	-2000	9
AHV12V2KV10MAW	2000	10	AHV12VN2KV10MAW	-2000	10
AHV12V2500V1MAW	2500	1	AHV12VN2500V1MAW	-2500	1



Part #	Output Voltage (V)	Output Current (mA)	Part #	Output Voltage (V)	Output Current (mA)
AHV12V2500V2MAW	2500	2	AHV12VN2500V2MAW	-2500	2
AHV12V2500V3MAW	2500	3	AHV12VN2500V3MAW	-2500	3
AHV12V2500V4MAW	2500	4	AHV12VN2500V4MAW	-2500	4
AHV12V2500V5MAW	2500	5	AHV12VN2500V5MAW	-2500	5
AHV12V2500V6MAW	2500	6	AHV12VN2500V6MAW	-2500	6
AHV12V2500V7MAW	2500	7	AHV12VN2500V7MAW	-2500	7
AHV12V2500V8MAW	2500	8	AHV12VN2500V8MAW	-2500	8
AHV12V3KV1MAW	3000	1	AHV12VN3KV1MAW	-3000	1
AHV12V3KV2MAW	3000	2	AHV12VN3KV2MAW	-3000	2
AHV12V3KV3MAW	3000	3	AHV12VN3KV3MAW	-3000	3
AHV12V3KV4MAW	3000	4	AHV12VN3KV4MAW	-3000	4
AHV12V3KV5MAW	3000	5	AHV12VN3KV5MAW	-3000	5
AHV12V3KV6MAW	3000	6	AHV12VN3KV6MAW	-3000	6
AHV12V3500V1MAW	3500	1	AHV12VN3500V1MAW	-3500	1
AHV12V3500V2MAW	3500	2	AHV12VN3500V2MAW	-3500	2
AHV12V3500V3MAW	3500	3	AHV12VN3500V3MAW	-3500	3
AHV12V3500V4MAW	3500	4	AHV12VN3500V4MAW	-3500	4
AHV12V3500V5MAW	3500	5	AHV12VN3500V5MAW	-3500	5
AHV12V4KV1MAW	4000	1	AHV12VN4KV1MAW	-4000	1
AHV12V4KV2MAW	4000	2	AHV12VN4KV2MAW	-4000	2
AHV12V4KV3MAW	4000	3	AHV12VN4KV3MAW	-4000	3
AHV12V4KV4MAW	4000	4	AHV12VN4KV4MAW	-4000	4
AHV12V4KV5MAW	4000	5	AHV12VN4KV5MAW	-4000	5
AHV12V4500V1MAW	4500	1	AHV12VN4500V1MAW	-4500	1
AHV12V4500V2MAW	4500	2	AHV12VN4500V2MAW	-4500	2
AHV12V4500V3MAW	4500	3	AHV12VN4500V3MAW	-4500	3
AHV12V4500V4MAW	4500	4	AHV12VN4500V4MAW	-4500	4
AHV12V5KV1MAW	5000	1	AHV12VN5KV1MAW	-5000	1
AHV12V5KV2MAW	5000	2	AHV12VN5KV2MAW	-5000	2



Part #	Output Voltage (V)	Output Current (mA)	Part #	Output Voltage (V)	Output Current (mA)
AHV12V5KV3MAW	5000	3	AHV12VN5KV3MAW	-5000	3
AHV12V5KV4MAW	5000	4	AHV12VN5KV4MAW	-5000	4
AHV12V5500V1MAW	5500	1	AHV12VN5500V1MAW	-5500	1
AHV12V5500V2MAW	5500	2	AHV12VN5500V2MAW	-5500	2
AHV12V5500V3MAW	5500	3	AHV12VN5500V3MAW	-5500	3
AHV12V6KV1MAW	6000	1	AHV12VN6KV1MAW	-6000	1
AHV12V6KV2MAW	6000	2	AHV12VN6KV2MAW	-6000	2
AHV12V6KV3MAW	6000	3	AHV12VN6KV3MAW	-6000	3
AHV12V6500V1MAW	6500	1	AHV12VN6500V1MAW	-6500	1
AHV12V6500V2MAW	6500	2	AHV12VN6500V2MAW	-6500	2
AHV12V7KV1MAW	7000	1	AHV12VN7KV1MAW	-7000	1
AHV12V7KV2MAW	7000	2	AHV12VN7KV2MAW	-7000	2
AHV12V8KV1MAW	8000	1	AHV12VN8KV1MAW	-8000	1
AHV12V9KV1MAW	9000	1	AHV12VN9KV1MAW	-9000	1
AHV12V10KV1MAW	10000	1	AHV12VN10KV1MAW	-10000	1



DIMENSIONS

Connecting Lead Wire Sizes and Lengths

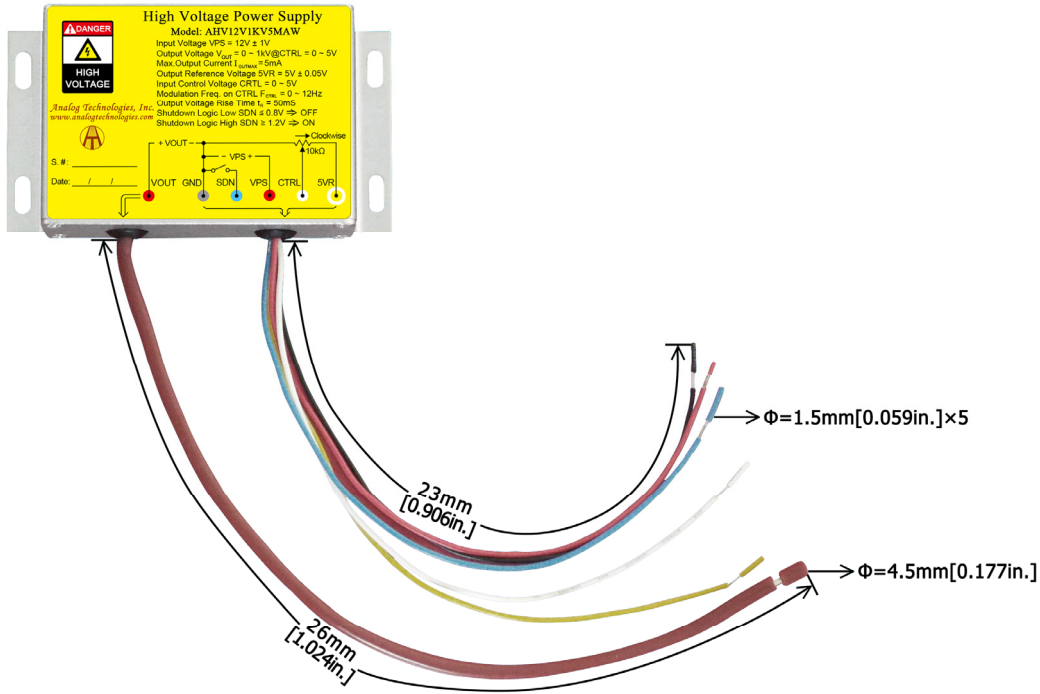

Figure 13. Connecting Lead Wires of AHV12V1KV5MAW

Lead Wires	Diameter		Length	
	mm	inch	mm	inch
Thick brown lead wire	4.5	0.177	26 ± 1	1.024 ± 0.039
Yellow, red, blue, black and white lead wires	1.5	0.059	23 ± 1	0.906 ± 0.039



Outline Dimensions

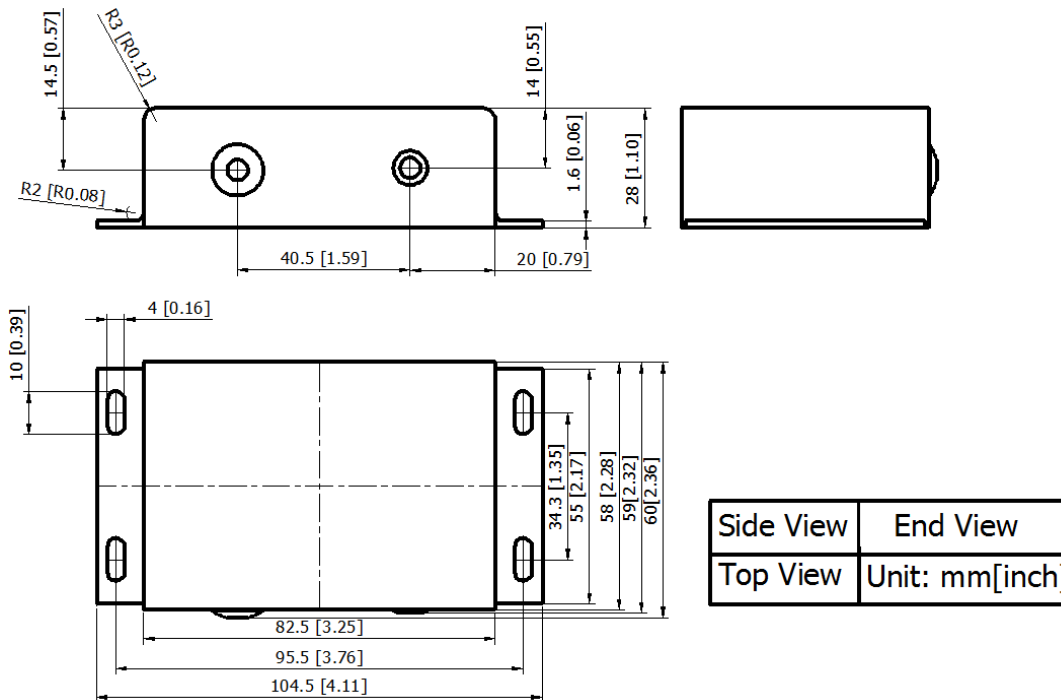

Figure 14. Outline Dimensions



NOTICE

1. ATI warrants performance of its products for one year to the specifications applicable at the time of sale, except for those being damaged by excessive abuse. Products found not meeting the specifications within one year from the date of sale can be exchanged free of charge.
2. ATI reserves the right to make changes to its products or to discontinue any product or service without notice, and advise customers to obtain the latest version of relevant information to verify, before placing orders, that the information being relied on is current and complete.
3. All products are sold subject to the terms and conditions of sale supplied at the time of order acknowledgment, including those pertaining to warranty, patent infringement, and limitation of liability. Testing and other quality control techniques are utilized to the extent ATI deems necessary to support this warranty. Specific testing of all parameters of each device is not necessarily performed, except those mandated by government requirements.
4. Customers are responsible for their applications using ATI products. In order to minimize risks associated with the customers' applications, adequate design and operating safeguards must be provided by the customers to minimize inherent or procedural hazards. ATI assumes no liability for applications assistance or customer product design.
5. ATI does not warrant or represent that any license, either express or implied, is granted under any patent right, copyright, mask work right, or other intellectual property right of ATI covering or relating to any combination, machine, or process in which such products or services might be or are used. ATI's publication of information regarding any third party's products or services does not constitute ATI's approval, warranty or endorsement thereof.
6. IP (Intellectual Property) Ownership: ATI retains the ownership of full rights for special technologies and/or techniques embedded in its products, the designs for mechanics, optics, plus all modifications, improvements, and inventions made by ATI for its products and/or projects.