

DATE	REV	ECN	APP'D. BY
04/08/21	A0	-	JME

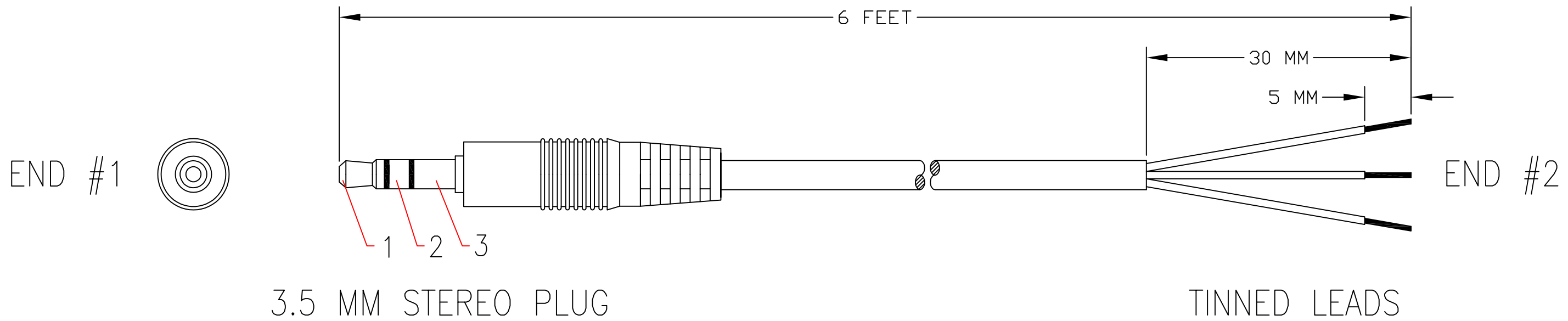

P/N STRUCTURE
 BC-A3ML006F

- UNITS
F = FEET
- LENGTH
006 = 6.0
- END #2
L = LEADS
- END #1
M = MALE
- CONNECTOR TYPE
3 = 3 PIN STEREO
- CODE
A = AUDIO
- FAMILY

- NOTES:**
1. CABLE: 26 AWG + TALC, 3.5MM OD, BLACK JACKET
 2. CONNECTORS: ϕ 3.5mm 3 PIN STEREO PLUG, MALE, MOLDED BLACK PVC
 2. LEADS: 30 MM STRIPPED JACKET, 5 MM TINNED

WIRING DIAGRAM

3.5 MM SP	LEADS
1	TINNED 5mm BROWN
2	TINNED 5mm RED
3	TINNED 5mm BLACK



THIRD ANGLE PROJECTION			206 Van Vorst Street Jersey City, NJ 07302 +1 201 432 0463 http://www.belfuse.com
DO NOT SCALE DRAWING DRAWING IS SUBJECT TO CHANGE WITHOUT NOTICE	TITLE: 3.5 MM STEREO PLUG, MALE, TO STRIPPED LEADS CABLE ASSEMBLY	DRN BY: BTS	DATE 04/07/21
DIMENSIONS: INCHES [METRIC] UNLESS OTHERWISE SPECIFIED TOLERANCES ARE \pm .005 [0.13] ANGLES ARE \pm 1°	THIS DRAWING AND THE SUBJECT MATTER SHOWN THEREON ARE CONFIDENTIAL AND THE PROPRIETARY PROPERTY OF STEWART CONNECTOR AND SHALL NOT BE REPRODUCED, COPIED, OR USED IN ANY MANNER WITHOUT PRIOR WRITTEN CONSENT OF STEWART CONNECTOR. ONE OR MORE U.S. PATENTS MAY APPLY TO THIS PRODUCT. FOR DETAILS, PLEASE VISIT: HTTP://BELFUSE.COM/STEWART/STEWART_PATENTS/	APPD BY: JME	DATE 04/08/21
SHEET NO. 1 OF 1		DWG NO. CT999253	REV. A0