

LM9072

Dual Tracking Low-Dropout System Regulator

General Description

The LM9072 is a high performance voltage regulator system with operational and protection features that address many requirements of automotive applications. Two regulated outputs are provided. The main regulator provides a precision 2% maximum tolerance 5V output at 350mA with a low dropout characteristic. The second regulator provides a 5V output that tracks the main regulator output voltage within 1.5% with load currents up to 80mA. The tracking output is ideal for use in powering remotely located sensors with outputs that are ratiometric to the main system supply. This output is fully protected from short circuits to ground or the unregulated input supply (ignition or battery potentials in automotive applications).

The LM9072 also contains a programmable delayed system reset output. Two control inputs are provided. An ON/OFF input intended for connection to an ignition switch, and a Keep Alive input to allow a system to remain powered after ignition has been switched OFF.

For EMC concerns the LM9072 remains fully operational and does not generate false reset signals while subjected to, 1MHz to 400 MHz bulk current injection signals greater than 100 mA on the input supply and tracking output lines.

Features

- Two 5V regulated outputs:
 - 350 mA, 2% Main output
 - 80 mA, 1.5% Tracking output
- Good EMI (1 MHz to 400 MHz, BCI) immunity
- Separate ON/OFF and Keep-Alive control inputs
- Less than 100 μ A quiescent current in OFF state
- Programmable delayed reset output
- Input transient protection over 60V to -45V
- Tracking output protected from shorts to battery
- Less than 1V dropout at full load
- -40°C to +125°C operating temperature range
- Surface mount TO-263 Power Package

Typical Applications

- Automotive module supply power conditioning
- Remote sensor biasing
- Ratiometric to supply sensor detection
- Continuous operation for save routines and EPROM programming after power down command
- Safety related systems—EMC operational

Connection Diagram and Ordering Information

9-Lead TO-263 Surface Mount Power Package



1290602

Backside metal is internally connected to ground.

Order Number **LM9072S**
See NS Package Number **TS9A**

9-Lead TO-220 Package

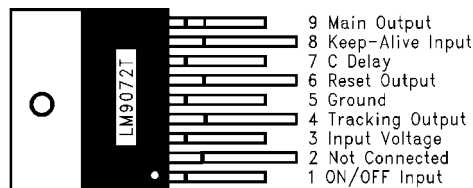

1290603

Order Number **LM9072T**
See NS Package Number **TA9A**

Absolute Maximum Ratings (Note 1)

If Military/Aerospace specified devices are required, please contact the National Semiconductor Sales Office/Distributors for availability and specifications.

Input Voltage (Continuous)	-45V to 45V
Input Voltage (Transient, $t \leq 400$ ms)	60V
Forced Output Voltages	
Main Output	-0.3V to 7V
Tracking Output	-0.3V to 27V
ON/OFF Input Voltage (Note 6)	-0.3V to 16V
ON/OFF Input Current	± 20 mA
Keep Alive In, Reset Out, C_{DELAY} Voltage	-0.3V to 7V
Junction Temperature	150°C

Storage Temperature Range	-65°C to +150°C
ESD Susceptibility (Note 2)	2000V
Lead Temperature (Soldering, 10 seconds)	265°C

Operating Ratings (Note 1)

Input Voltage Range	6V to 27V
Ambient Temperature Range	-40°C to +125°C
TO-220 Thermal Resistance, θ_{J-C}	3°C/W
TO-220 Thermal Resistance, θ_{J-A} (Note 7)	73°C/W
TO-263 Thermal Resistance, θ_{J-C}	3°C/W
TO-263 Thermal Resistance, θ_{J-A} (Note 8)	80°C/W

Electrical Characteristics (Note 9)

6.0V $\leq V_{IN} \leq 19V$, $T_{CASE} = 25^\circ\text{C}$, unless otherwise specified. $C_{OUT} \geq 6 \mu\text{F}$ with $0.3\Omega \leq \text{ESR} \leq 3\Omega$ on each regulator output.

Symbol	Parameter	Conditions	Min	Max	Units
MAIN REGULATOR					
V_{MAIN}	Main Output Voltage	$5 \text{ mA} \leq I_{LOAD} \leq 350 \text{ mA}$ $-40^\circ\text{C} \leq T_{CASE} \leq 125^\circ\text{C}$	4.9	5.1	V
		$19\text{V} \leq V_{IN} \leq 30\text{V}$ $5 \text{ mA} \leq I_{LOAD} \leq 350 \text{ mA}$ $-40^\circ\text{C} \leq T_{CASE} \leq 125^\circ\text{C}$	4.8	5.2	V
R_{MLOAD}	Load Regulation	$V_{IN} = 16\text{V}$, $5 \text{ mA} \leq I_{LOAD} \leq 350 \text{ mA}$		25	mV
R_{MLINE}	Line Regulation	$I_{LOAD} = 350 \text{ mA}$, $8\text{V} \leq V_{IN} \leq 16\text{V}$		25	mV
V_{MDO}	Dropout Voltage, $V_{IN} - V_{MAIN}$	$V_{IN} > 5.5\text{V}$, $5 \text{ mA} \leq I_{LOAD} \leq 350 \text{ mA}$ (Note 5)		0.8	V
V_{SD}	Overvoltage Shutdown Threshold		30	36	V
I_{MSC}	Output Short Circuit Current	$R_L = 1\Omega$	450	1000	mA
R_{MRR}	Ripple Rejection	$V_{IN} = 9\text{V}$, $50 \leq \text{Freq} \leq 20 \text{ kHz}$, $V_{RIPPLE} = 4V_{P-P}$	40		dB
TRACKING REGULATOR					
V_{TRACK}	Tracking Output Voltage	$1 \text{ mA} \leq I_{LOAD} \leq 80 \text{ mA}$ $-40^\circ\text{C} \leq T_{CASE} \leq 125^\circ\text{C}$	4.85	5.15	V
		$19\text{V} \leq V_{IN} \leq 30\text{V}$ $1 \text{ mA} \leq I_{LOAD} \leq 80 \text{ mA}$ $-40^\circ\text{C} \leq T_{CASE} \leq 125^\circ\text{C}$	4.725	5.275	V
V_{ERROR}	Output Tracking Error ($V_{MAIN} - V_{TRACK}$)	$1 \text{ mA} \leq I_{LOAD} \leq 80 \text{ mA}$	-50	50	mV
V_{TDO}	Dropout Voltage, $V_{IN} - V_{TRACK}$	$V_{IN} > 5.5\text{V}$, $1 \text{ mA} \leq I_{LOAD} \leq 80 \text{ mA}$ (Note 5)		0.8	V
I_{TSC}	Output Short Circuit Current	$R_L = 1\Omega$		200	mA
V_{TSC}	Output Short Circuit Voltage	No Effect On Other Functions	-2	27	V
R_{TRR}	Ripple Rejection	$V_{IN} = 9\text{V}$, $50 \leq \text{Freq} \leq 20 \text{ kHz}$, $V_{RIPPLE} = 4V_{P-P}$	40		dB
INPUT CURRENT					
I_{qOFF}	Quiescent Input Current with Both Regulators OFF	$8\text{V} \leq V_{IN} \leq 16\text{V}$		40	μA
		$16\text{V} \leq V_{IN} \leq 42\text{V}$		10	mA
I_q	No Load Quiescent Current	$8\text{V} \leq V_{IN} \leq 19\text{V}$, $I_L = 0 \text{ mA}$		15	mA

Symbol	Parameter	Conditions	Min	Max	Units
$I_{N_{ON}}$	Additional Input Current with Both Regulators ON	$V_{IN} > 8V$, $I_{Ltotal} = I_{Lmain} + I_{Ltrack}$ $I_{Ltotal} = 350\text{ mA} + 80\text{ mA} = 430\text{ mA}$		1.2	$\times I_{Ltotal}$
$I_{in_{do}}$	Additional Input Current in Dropout	$0V < V_{IN} < 8V$, (Note 4) $I_{Ltotal} = I_{Lmain} + I_{Ltrack}$ $I_{Ltotal} = 350\text{ mA} + 80\text{ mA} = 430\text{ mA}$		1.5	$\times I_{Ltotal}$
RESET OUTPUT					
V_{THRL}	Low Switching Threshold	V_{MAIN} Output Controls Reset	4.45	4.75	V
V_{THRH}	High Switching Threshold	V_{MAIN} Output Controls Reset	5.40	5.75	V
V_{LOW}	Logic Low Output Voltage	$1V \leq V_{MAIN} \leq V_{THRL}$, $R_{RESET} = 50\text{ k}\Omega$ to V_{MAIN}		0.4	V
V_{HIGH}	Logic High Output Voltage	Normal Operation, $V_{THRL} \leq V_{MAIN} \leq V_{THRH}$, $I_{SOURCE} = 0$	$V_{MAIN} - 50\text{ mV}$	V_{MAIN}	V
R_{P-U}	Internal Output Pull-Up Resistance		2.4	6.0	k Ω
T_{DELAY}	Reset Delay Interval	$C_{DELAY} = 0.1\text{ }\mu\text{F}$ (Low Leakage), I_{DELAY} for Charging the Delay Capacitor is Typically $6\text{ }\mu\text{A}$	35	70	ms
T_{RISE}	Output Rise Time	From 10% V_{MAIN} to 90% V_{MAIN} $C_{LRESET} = 50\text{ pF}$		1.5	μs
T_{FALL}	Output Fall Time	From 90% V_{MAIN} to 10% V_{MAIN} $C_{LRESET} = 50\text{ pF}$		0.5	μs
CONTROL INPUTS					
V_{ON}	ON Threshold for ON/OFF Input	$R_{SERIES} = 22\text{ k}\Omega$	3.5	4.5	V
V_{OFF}	OFF Threshold for ON/OFF Input	$R_{SERIES} = 22\text{ k}\Omega$ (Note 3)	1.5	2.5	V
$I_{ON/OFF}$	ON/OFF Input Current	$1.4V \leq V_{ON/OFF} \leq 4.5V$ $-0.3V \leq V_{ON/OFF} \leq 7V$ (Note 6)	1 -1	12 5	μA mA
ON_{K-A}	Turn ON Threshold for Keep Alive Input		2		V
OFF_{K-A}	Turn OFF Threshold for Keep Alive Input	(Note 3)		0.8	V
R_{P-D}	Pull-Down Resistance at Keep Alive Input	$0V \leq V_{K-A} \leq 5V$	5	40	k Ω
<p>Note 1: Absolute Maximum Ratings indicate limits beyond which damage to the device may occur. Operating Ratings indicate conditions for which the device remains functional but do not guarantee specific performance limits. For guaranteed specifications and test conditions see the Electrical Characteristics.</p> <p>Note 2: Human body model, 150 pF capacitor discharged through a 1.5 kΩ resistor.</p> <p>Note 3: If either control input is left open circuited the regulators will turn OFF.</p> <p>Note 4: The input quiescent current will increase when the regulators are in dropout conditions. The amount of additional input currents is a direct function of the total load current on both outputs. The peak increase in current is limited to 50% of the total load current.</p> <p>Note 5: The dropout voltage specifications actually indicate the saturation voltage of the PNP power transistors used in each regulator. Over the full load current and temperature ranges both regulators will output at least 4.7V with an input voltage of only 5.5V.</p> <p>Note 6: The ON/OFF input is internally clamped to a 7V zener diode through a 1 kΩ resistor.</p> <p>Note 7: Exceeding the Maximum Allowable power dissipation will cause excessive die temperature, and the device will go into thermal shutdown. The θ_{J-A} value for the TO-220 package (still air, no additional heat sink) is 73°C/W. The effective θ_{J-A} value of the TO-220 package can be reduced by using conventional heat sink methods.</p> <p>Note 8: Exceeding the Maximum Allowable power dissipation will cause excessive die temperature, and the device will go into thermal shutdown. The θ_{J-A} value for the TO-263 package (still air, no additional heat sink) is 80°C/W. The effective θ_{J-A} value of the TO-263 package can be reduced by increasing the printed circuit board area that is connected (soldered) to the package tab. Using 1 ounce (1.4 mils thick) copper clad with no solder mask, an area of 0.5 square inches will reduce θ_{J-A} to 50°C/W, an area of 1.0 square inches will reduce θ_{J-A} to 37°C/W, and an area of 1.6 square inches will reduce θ_{J-A} to 32°C/W. If the printed circuit board uses a solder mask, the copper clad area should be increased by at least 50% to maintain a similar θ_{J-A} rating.</p> <p>Note 9: Datasheet min/max specifications are guaranteed by design, test, and/or statistical analysis.</p>					

Typical Performance Characteristics ($T_A = 25^\circ\text{C}$ unless otherwise specified)

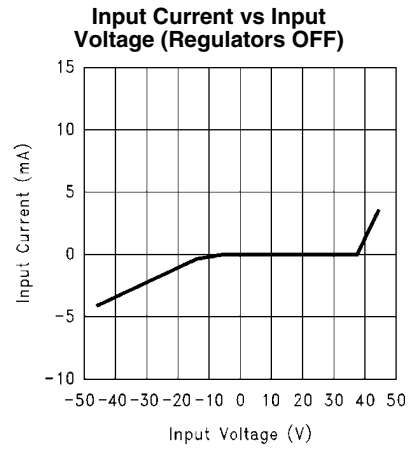
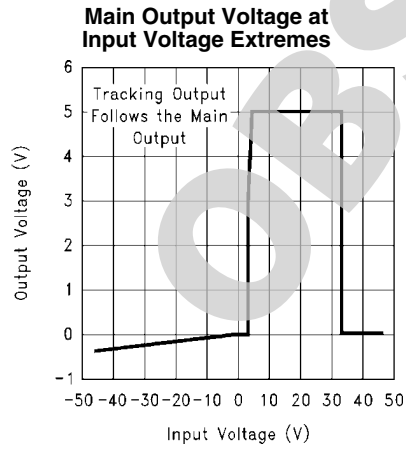
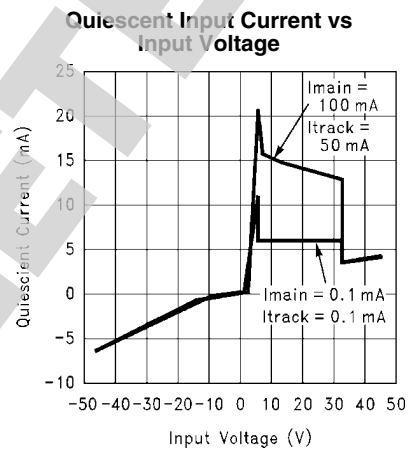
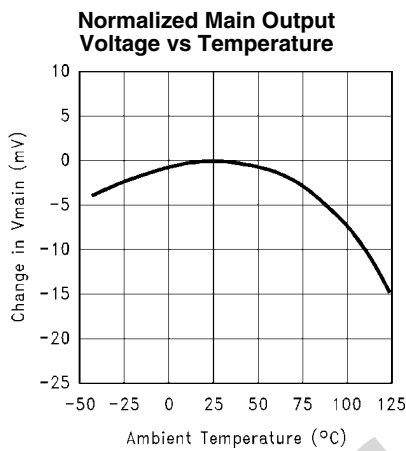
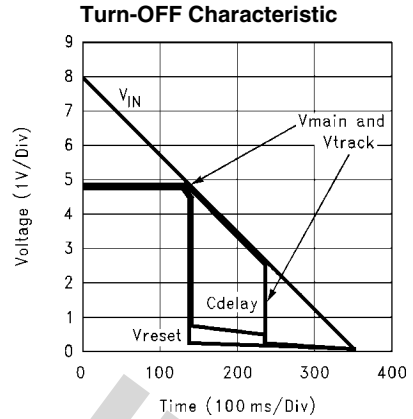
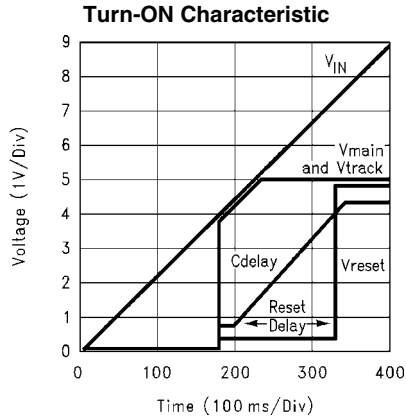

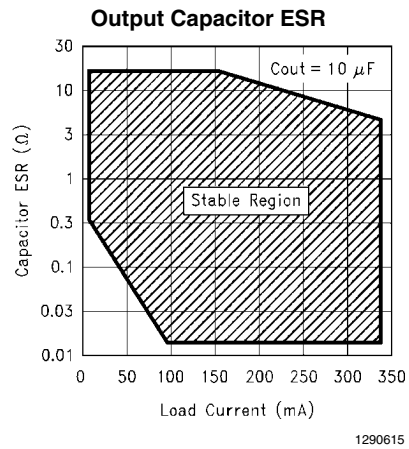
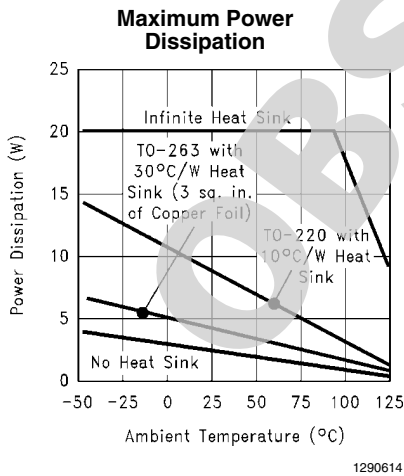
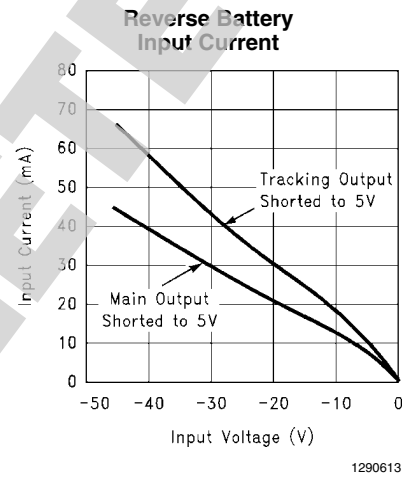
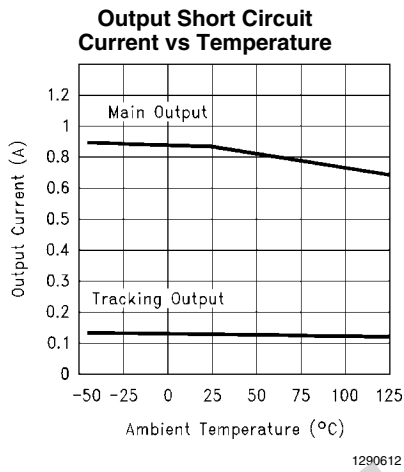
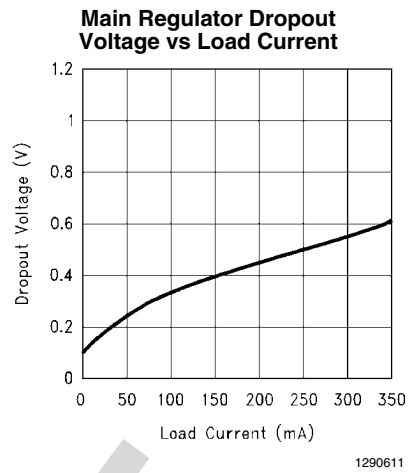
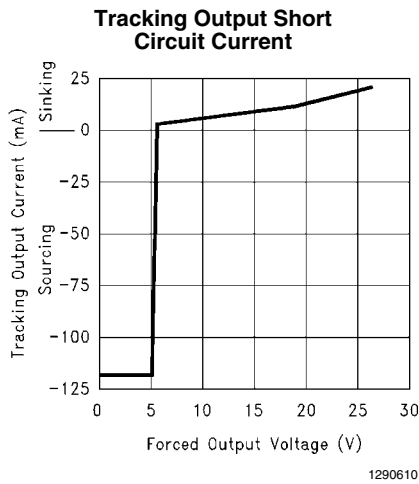

Operational Characteristics

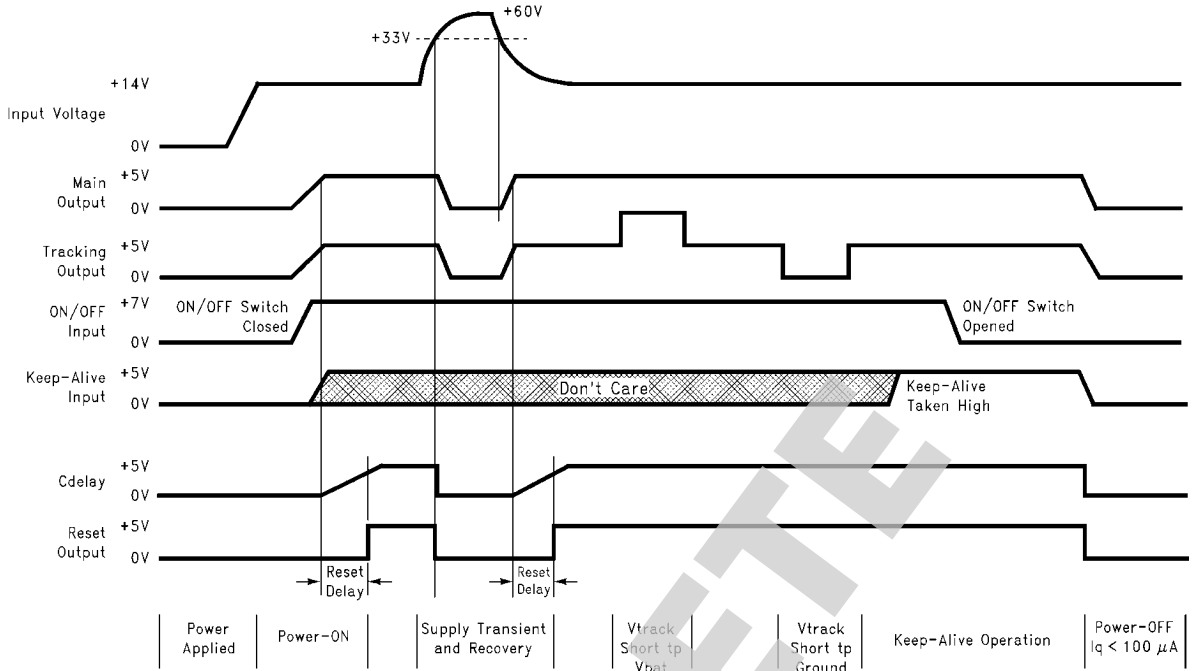

1290616

Control Logic Truth Table

ON/OFF Input	Keep-Alive Input	Main Output Voltage	Tracking Output Voltage	Reset Output	Operating Condition
L	L	0V	0V	0V	OFF, Input Current < 100 μA
↑	L	5V	5V	After Delay	Outputs Turn ON, Power ON Delayed Reset
H	X	5V	5V	5V	Normal ON Condition
H	X	< 4.45V	< 4.45V	0V	Main Output Pulled Out of Regulation, Reset Flag Generated
↓	H	5V	5V	5V	Keep-Alive, Continued Normal Operation
L	↑	5V	5V	After Delay	Outputs Turned ON by Keep-Alive Input

Application Information

PIN DESCRIPTION AND FUNCTIONALITY

The LM9072 is a precision dual tracking voltage regulator optimized for use in powertrain module applications but will also find use in a wide variety of automotive and industrial applications where precision supply regulation is required in harsh operating environments. The following will describe the functionality of each of the package pins.

INPUT VOLTAGE (Pin 3)

The LM9072 has been designed to connect directly to the ignition or battery supply in automotive applications. For this type of supply the regulator has been designed to withstand up to +60V and -45V supply transients such as load dump. An overvoltage shut down protection scheme turns OFF both

of the regulator outputs should supply transients exceed typically +33V to fully protect all load circuitry. This higher threshold allows normal operation with 24 V_{DC} applied to the input as in the event when two batteries are used to start a vehicle. Protection of the system is also provided for inadvertent reverse polarity battery connections.

The current drain on the supply line is directly proportional to the load currents on the two voltage regulators. With no load current on either output the regulator requires 15 mA maximum quiescent current for biasing internal circuitry. During dropout conditions ($V_{IN} < 5.5V$) the additional input current can rise to 50% of the total load current. With less than 4V applied to the input, internal biasing circuitry shuts OFF.

When *switched* OFF the regulator can remain connected to the battery supply with a current drain of less than 100 μA .

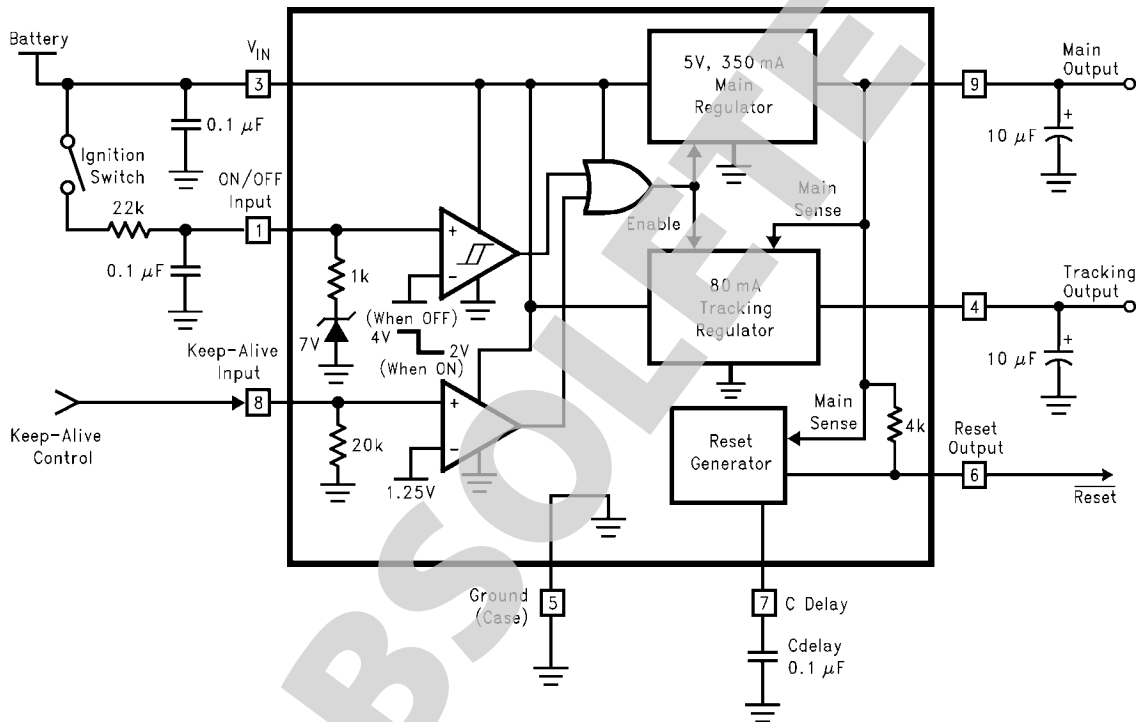

1290617

FIGURE 1. Circuit Block Diagram

MAIN OUTPUT (Pin 9)

The Main Output regulator provides a well controlled (3% tolerance maximum) 5V supply line with a total load current ranging up to 350 mA. This relatively high level of output current is sufficient to provide power to a large number of load circuits in a variety of module applications.

This output has a short to ground current limit between 500 mA and 1A. The Main output can also withstand a short circuit to potentials up to 7V.

To maintain stability of this supply line an output bypass capacitor is required. This capacitor must be at least 6 μF with an equivalent series resistance (ESR) between 0.3 Ω and 3 Ω over temperature.

The Main Output is sensed for the generation of the system reset output. Feedback from the Main Output is also used to control the output voltage of the tracking regulator.

TRACKING OUTPUT (Pin 4)

The Tracking Output regulator is a key feature of the LM9072. This output provides a voltage that directly tracks the main output voltage within 1.5%. This 80 mA output is provided to bias sensors and other devices located external to the main system module.

For providing remote power the Tracking Output is fully protected against short circuit connections to the battery or input supply (up to 27V) and to ground. These shorted fault conditions do not affect the operation of the main supply nor generate a reset of the system.

The tracking characteristic allows for ratiometric operation of sensors by providing power that is directly proportional to the system supply. Similar to the main output a bypass capacitor is required for stability. This capacitor should also be greater than 6 μF with an ESR between 0.3 Ω and 3 Ω .

RESET OUTPUT (Pin 6)

The Reset Output is an active low logic signal provided to reset a system microcontroller on power up and in the event that the Main Output supply falls out of regulation. This output is guaranteed to provide a logic low level (< 0.4V) whenever the Main Output supply is below 4.45V or is pulled above 5.75V. This general reset prevents erratic system operation which may occur with out-of-specification supply potentials.

The Reset Output has an active pull down to ground and a passive pull-up (through a 4 kΩ resistor) to the Main Output to ensure voltage compatibility with the system supply. Capacitive loading on this reset line will directly affect the rise time of the reset signal. The Reset Output will maintain a logic low level with a Main Output voltage of only 1V. Below 1V the active pull-down device switches OFF (sink current of only 500 μA), but with such a low supply potential, system controllers are generally inoperative.

The Reset Output has a built-in delay time interval which is programmable by the selection of the delay capacitor.

DELAY CAPACITOR (Pin 7)

The Delay Capacitor (C_{DELAY}) controls a time interval that the Reset Output remains low after the Main Output has established normal operating condition. This feature holds the system in reset for a time to allow all load circuitry to be properly biased before executing functions. This interval is applied at power-up and following any event that may trigger the system reset function.

Figure 2 illustrates the delayed reset generator. Two comparators continually monitor the Main Output supply. Window comparators C1 and C2 detect if the Main Supply is below 4.6V or exceeds 5.5V typically. If this is true (at power-on, for example) the control logic turns ON the discharge transistor and holds C_{DELAY} low (at 0.9V). Comparator C4 then outputs a logic low system Reset signal within 2 μs after detecting the out of regulation condition.

The Delay Capacitor remains discharged until the window comparator senses that the Main Output is within normal op-

erating range (C1 and C2 outputs are both low). When this condition is met, the discharge transistor is turned OFF and C_{DELAY} is charged positively by an internal 6 μA current source. The Reset Output will remain low until the delay capacitor has reached 4V, at which point it will go high and the system will begin normal operation. This delay time interval is controlled by the selection of C_{DELAY} and can be determined from the following equation:

$$T_{DELAY} = (0.5 \times 10^6) \cdot C_{DELAY}$$

Typically a 0.1 μF capacitor will produce a delay interval of 50 ms.

To ensure a consistent delay time interval, the discharge transistor is always latched ON by the window comparators, and can not be switched OFF to start a new delay interval until C_{DELAY} has been discharged to less than or equal to 0.9V. This sets a fixed starting voltage (0.9V) and ending voltage (4V) for the charging of the Delay Capacitor.

ON/OFF INPUT (Pin 1)

The ON/OFF Input enables both the Main and Tracking outputs. In a typical application this input is connected to the input supply through a series resistor (nominally 22 kΩ) and a switch (Ignition, as an example). When the switch is closed this input is pulled high and switches ON both regulator outputs. This input is internally clamped to a 7V zener diode through a series 1 kΩ resistor. The external series resistor together with an optional 0.1 μF capacitor to ground are optional to provide filtering and current limiting to withstand any transients that may appear on the input supply in order to maintain normal operation of the system.

The switching threshold of the ON/OFF comparator has 2V of hysteresis to ensure noise free control of the system. To turn the regulators ON this input must be taken above 4V. To turn the system OFF the ON/OFF Input must be open circuited or taken below 2V.

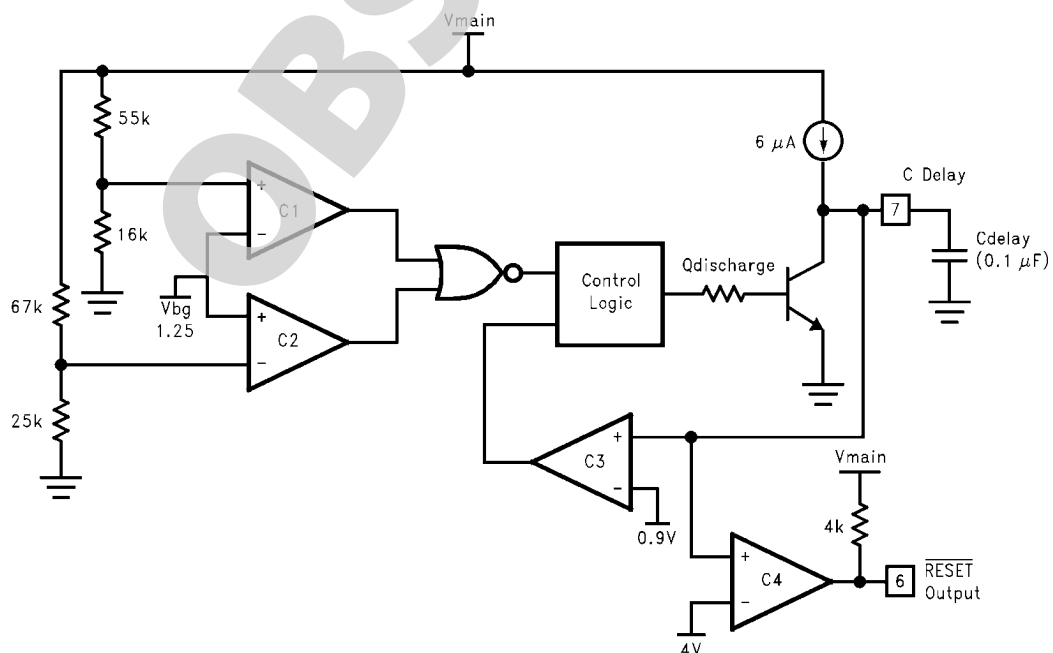

1290618

FIGURE 2. Reset Generator

KEEP-ALIVE INPUT (Pin 8)

This CMOS logic level compatible input provides a system with the ability to control its own ON/OFF sequencing. The Keep-Alive Input is OR'ed with the ON/OFF Input so either one can independently control the regulators.

As shown in the Operational Characteristics a system controller can take the Keep-Alive input high at any time. If the ON/OFF switch is opened, this high level on Keep-Alive will keep the regulators ON and the entire system operational. This control is useful for providing as much time as necessary

for a system to perform "housekeeping" chores such as programming EEPROM with system information prior to turning itself OFF (by taking the Keep-Alive Input low) and reverting to the low quiescent current state.

A second use of the Keep-Alive Input can be from other modules which need information from the module powered by the LM9072, *Figure 3*. A CMOS logic high level (> 2V) on this input will power up the system as needed independent from the normal ON/OFF switch.

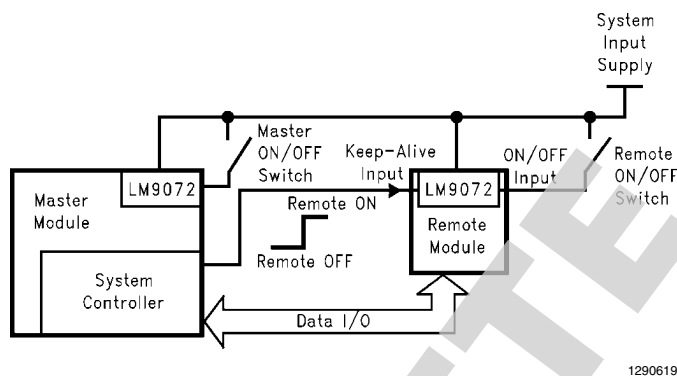

FIGURE 3. Remote ON/OFF Control

SYSTEM KEEP-ALIVE OPERATION

Figure 4 illustrates the basic concept of Keep-Alive operation. The LM9072 provides regulated supplies to an entire microcontroller based system or module including remote sensors. The system is switched ON or OFF by a switch connected to the unregulated input supply and the ON/OFF input, pin 1. When closed the regulators turn ON and the system is held in a reset state for the duration of the delayed reset interval controlled by C_{DELAY} .

Once normal operation of the system begins, the controller needs to set an output line connected to the Keep-Alive input, pin 8, high. The system remains in normal operation until switched OFF by opening the ON/OFF switch. With Keep-Alive high the entire system remains normally biased and will remain operational until the Keep-Alive input is taken low.

Transistor Q1 is shown as a means to inform the controller that the ON/OFF switch has been opened. This high level on an input line tells the controller that the system has been switched OFF. This indicates the start of the Keep-Alive interval. The system can perform whatever actions required to obtain the proper OFF state before actually powering down. These general housekeeping tasks can include putting external devices in the proper OFF condition and storing various system variables in EPROM for example. With the controller in command of the Keep-Alive interval these tasks can take whatever time necessary to complete.

When completed the controller takes the Keep-Alive input to a low level and the entire system shuts down. The LM9072

powers down to a low quiescent current mode with less than 100 μ A drawn from the input supply.

To initiate the Keep-Alive routine before actual power down, it is important for the system controller to know when the system has been switched OFF. To eliminate any interface between the controller and the ON/OFF switch and potentially noisy unregulated input supply, a simple logic scheme shown in *Figure 5* can be used. With this circuitry the Reset output from the LM9072 provides the ON/OFF sensing input to the controller.

When switched OFF, the main regulator output will fall out of regulation and generate a low logic level on the Reset output. This input to the controller provides the switch OFF indication and initiates the Keep-Alive interval.

Control of the Keep-Alive duration is set by a logic 1 on the Keep-Alive output line from the system controller. This high level prevents the Reset output from resetting the entire system and also gates the Keep-Alive input signal to the LM9072. The inverted Reset signal provides a logic 1 to the Keep-Alive input of the LM9072.

The Main output will only drop out of regulation for a very short time before the Keep-Alive input turns it back on.

The Reset output remains low for the delay time interval. When it returns high the Main output switches OFF and back ON again very quickly. This continues until the system controller takes the Keep-Alive output line to a logic low level.

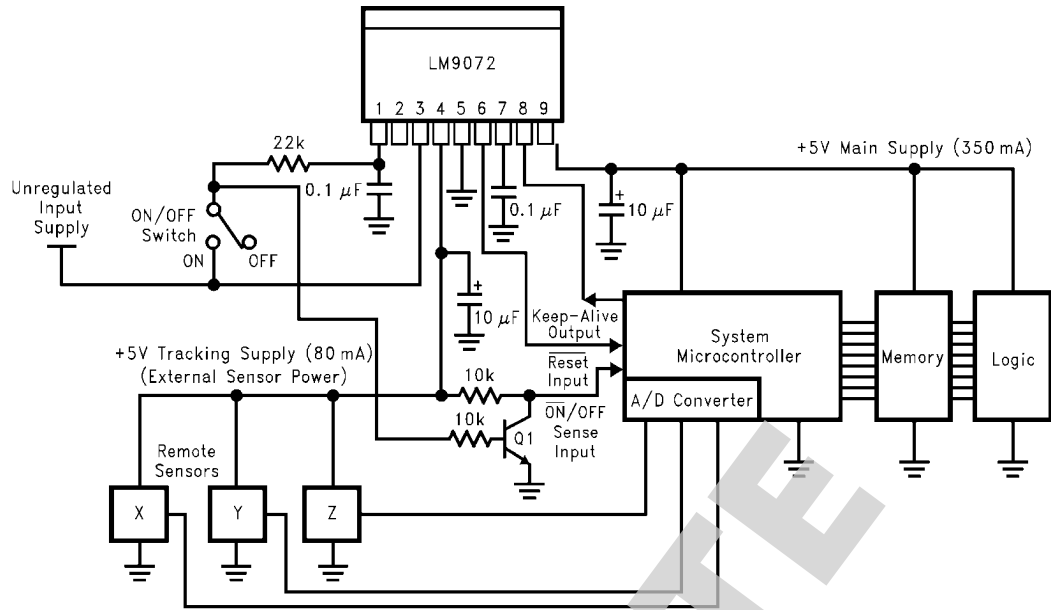

Control Waveforms

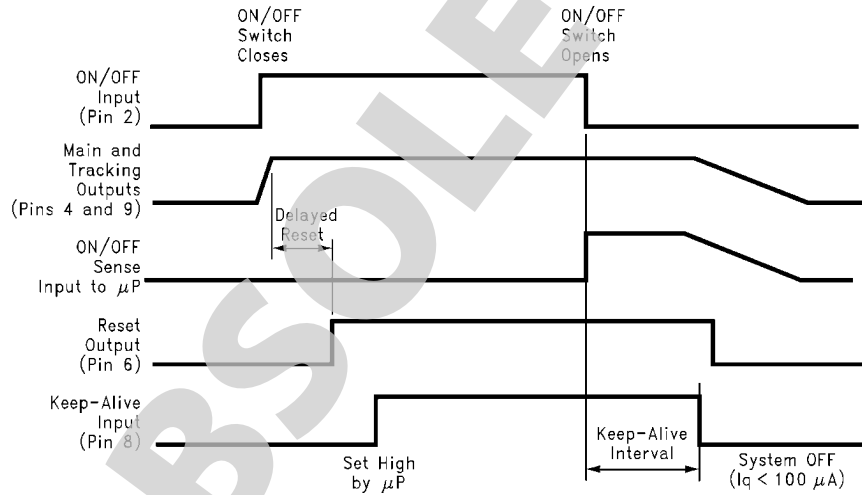

1290620

FIGURE 4. Basic Keep-Alive Operation

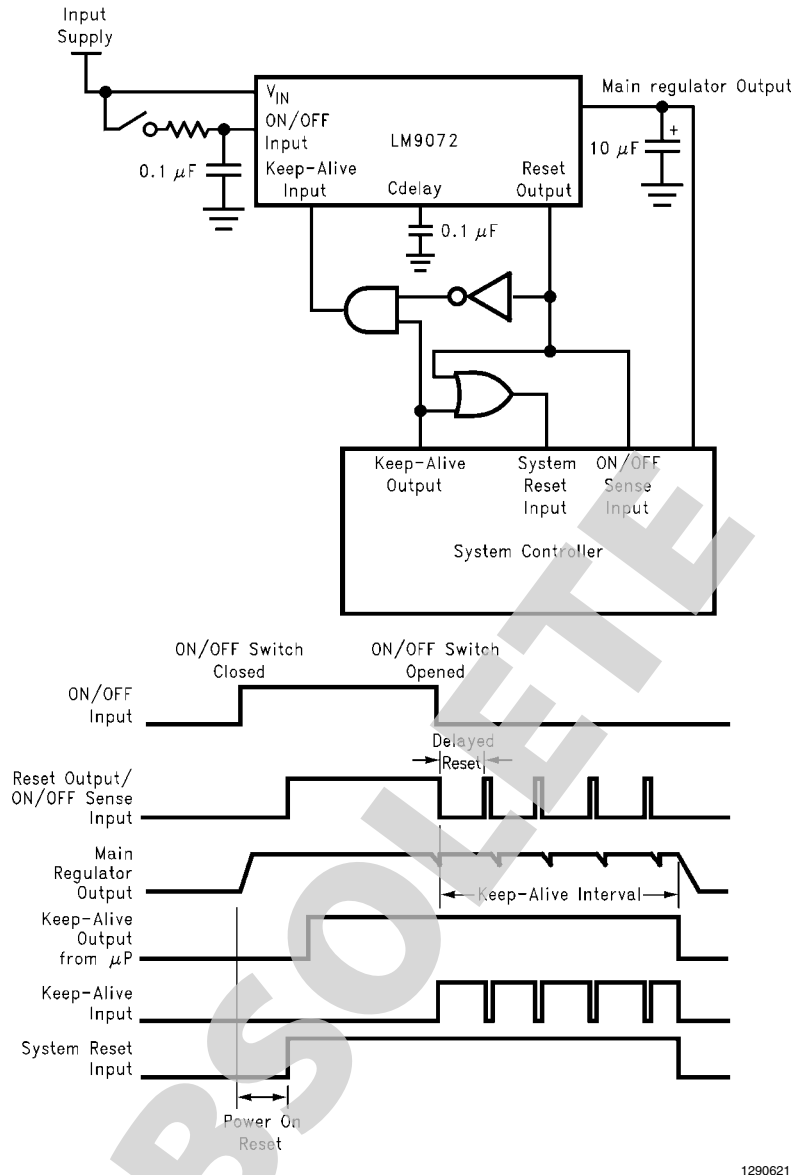

FIGURE 5. Simple Logic Configuration to Provide ON/OFF Sensing

SAFETY LATCH-OFF

To address a system FMEA (Failure Mode Effects Analysis) issue the Keep-Alive high level should be derived from the Tracking output regulator as shown in Figure 6. The issue stems from the “what-if” scenario whereby the system is in the Keep-Alive state and there is a short to ground on the Tracking Output regulator. If this output is powering remote sensors or systems, this becomes a more highly possible fault condition. Since a short on the Tracking output does not affect the Main output, which, if used to provide the Keep-Alive input

signal, would remain ON and draw 120 mA, the short circuit current of the Tracking regulator, from the input supply.

Using the Tracking output supply for Keep-Alive would prevent Keep-Alive operation during a short to ground fault and the excessive drain on the input supply. The inversion by the transistor will require a low level from the controller to allow Keep-Alive operation. The 24 kΩ pull-up resistor provides current limiting in the event of a Tracking output short to the unregulated/battery input supply.

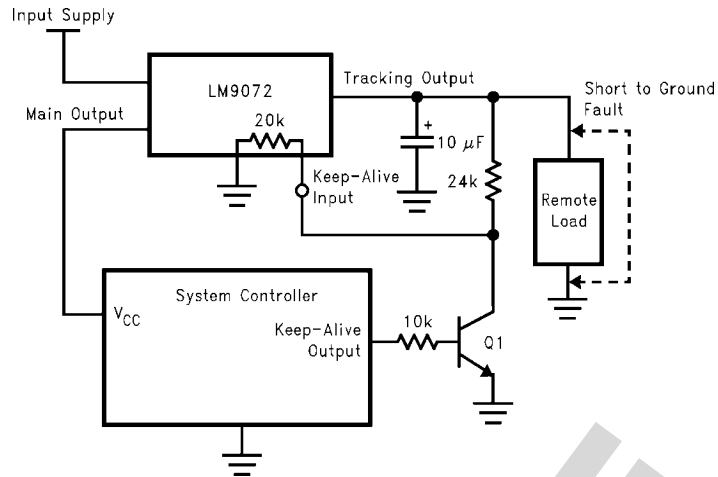

1290622

FIGURE 6. Safety Latch-OFF

INPUT STABILITY

Low dropout voltage regulators which utilize a PNP power transistor usually exhibit a large increase in current when in dropout ($V_{IN} < 5.5V$). This increase is caused by the saturation characteristics (β reduction) of the PNP transistor. To significantly minimize this increase in current the LM9072 detects when the PNP enters saturation and reduces the operating current.

This reduction in input current can create a stability problem in applications with higher load current (> 200 mA) where the input voltage is applied through a long length of wire which in effect add a significant amount of inductance in series with the input. The drop in input current may create a positive input voltage transient which may take the PNP out of saturation. If the input voltage is held constant at the threshold where the PNP is going in and out of saturation, an oscillation may be created.

This is only observed where a large series inductance is present in the input supply line and when the rise and fall time

of the input supply is very slow. If the application and removal of the input voltage changes at a rate greater than 500 mV/ms it will move through the dropout region of the regulator (V_{IN} of $3V$ to $5.5V$) too quickly for an oscillation to be established.

In the event that an oscillation is present, input bypassing can also help de-tune the resonance. *Figure 7* illustrates two input bypassing approaches. The straightforward addition of a larger valued electrolytic capacitor could suffice. In this case however, if reverse battery connections are a possibility it is necessary to add a series protection diode as shown to prevent damaging the polarized input capacitor.

An alternative input bypassing scheme is also shown. This eliminates the use of polarized input capacitors and a series protection diode. The values shown were derived empirically in a representative typical application. Appropriate values for any given application require experimentation.

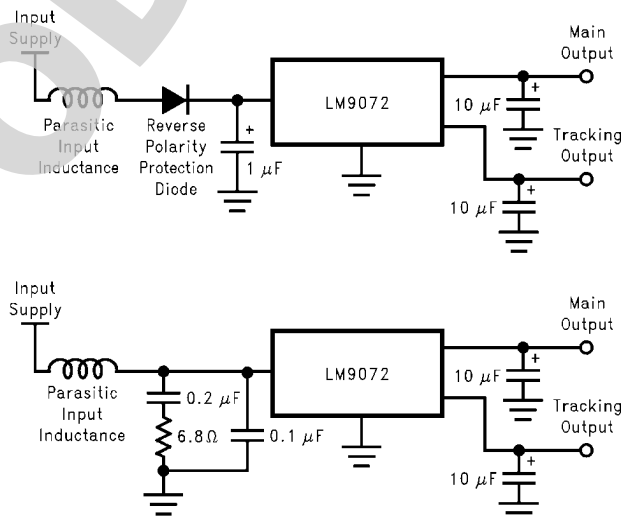

1290623

FIGURE 7. Input Bypassing

THERMAL MANAGEMENT

The LM9072 is packaged in both a TO-263 surface mount power package and a narrow lead-pitch TO-220 package. To obtain operation over the highest possible load current and input voltage ranges, care must be taken to control the operating temperature of the device. Thermal shutdown protection is built in, with a threshold above 150°C. Conventional heat-sinking techniques can be used with the TO-220 package. When applying the TO-263 package, on board heat-sinking is important to prevent premature thermal shutdown. More copper foil area under the tab of the device will directly improve the operating θ_{J-A} of the TO-263 package, which will reduce the junction temperature of the device.

The θ_{J-A} value for the TO-263 package (still air, no additional heat sink) is rated at 80°C/W. The effective θ_{J-A} value of the TO-263 package can be reduced by increasing the printed

circuit board area that is connected (soldered) to the package tab. Using 1 ounce (1.4 mils thick) copper clad with no solder mask, an area of 0.5 square inches will reduce θ_{J-A} to 50°C/W, an area of 1.0 square inches will reduce θ_{J-A} to 37°C/W, and an area of 1.6 square inches will reduce θ_{J-A} to 32°C/W. If the printed circuit board uses a solder mask, the copper clad area under the solder mask should be increased by at least 50% to maintain a similar θ_{J-A} rating.

The use of a double sided PC board with soldered filled vias between two planes of copper, as shown in Figure 8, will improve thermal performance while optimizing the PC board surface area required. Using the double sided PC board arrangement shown in Figure 8, with 1 ounce (1.4 mils thick) copper clad with no solder mask and solder filled vias, an area of 0.5 square inches on both sides will reduce θ_{J-A} to 43°C/W.

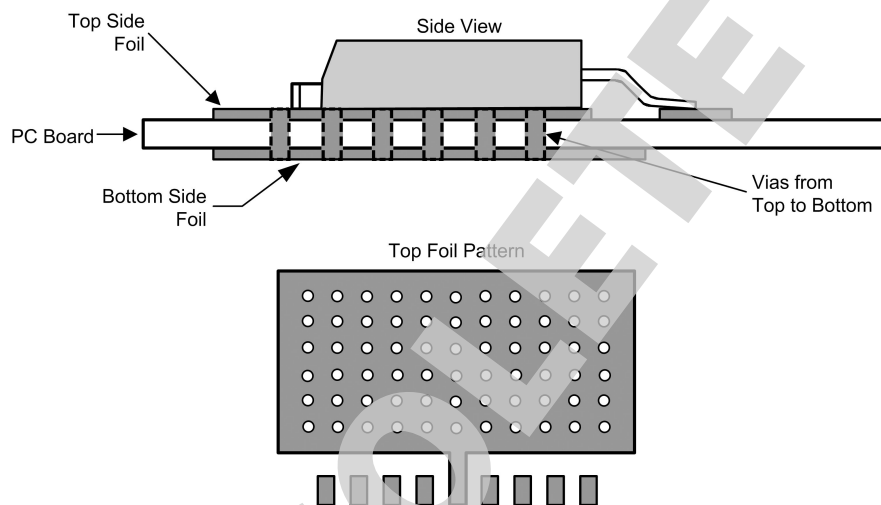

1290624

FIGURE 8. Typical TO-263 PC Board Heatsinking

Electro-Magnetic Compatibility (EMC)

The LM9072 offers good immunity to high frequency interference in a standard Bulk Current Injection (BCI) test (ISO11452 Part 4 test method). The following test conditions and configuration (Figure 9) can be used to observe this performance.

Frequency Range	1 MHz to 400 MHz
Modulation 1	CW (no modulation)
Modulation 2	1 kHz sine wave, 80% AM
Dwell Time	1 second
Frequency Steps	1 MHz (from 1 MHz to 10 MHz) 2 MHz (from 10 MHz to 200 MHz)

20 MHz (from 200 MHz to 400 MHz)

Test Method

Closed loop current probe

In this test configuration the current injected into either the input pin or the tracking output pin is increased until a reset output is generated. These two pins are the most critical as they typically will connect to a module through long lengths of wire most likely to pick up high frequency energy. Figure 10 illustrates examples of test results on the LM9072 with both types of modulation.

These results are just examples as actual results in any given application will depend on numerous external factors such as component selection, pc board layout, etc. The current power of the injected signal is expressed in dB relative to 1 mA (i.e., 40 dBmA = 100 mA).

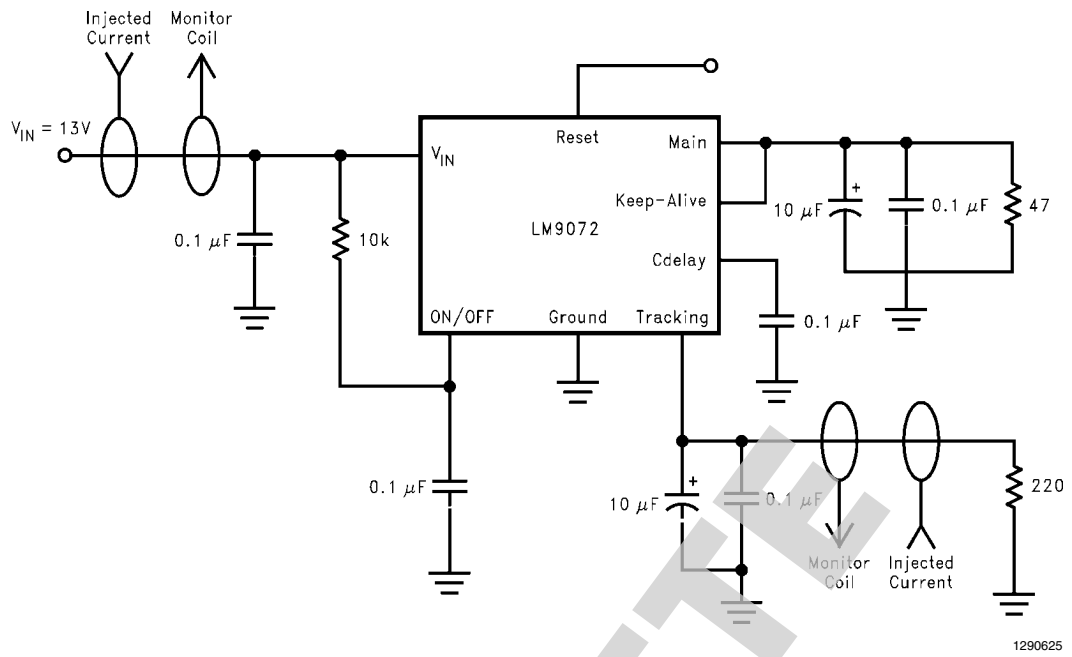
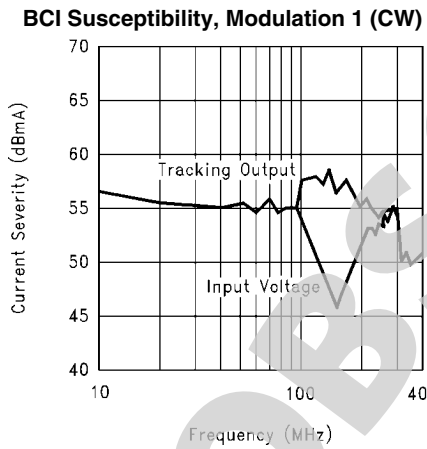
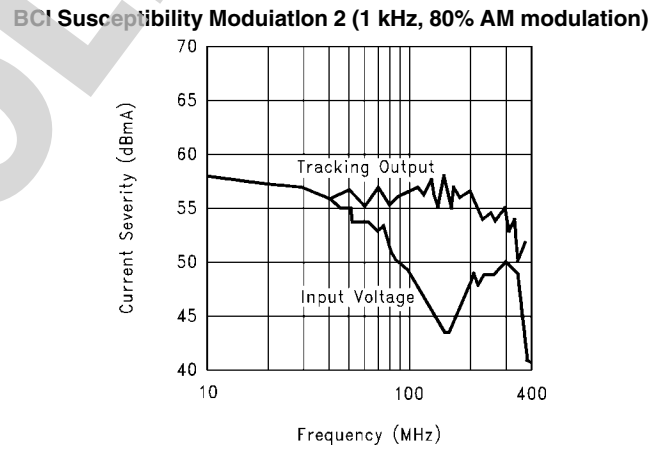

FIGURE 9. Bulk Current Injection Test Configuration



1290626



1290627

FIGURE 10. Examples of BCI Test Results

Physical Dimensions inches (millimeters) unless otherwise noted

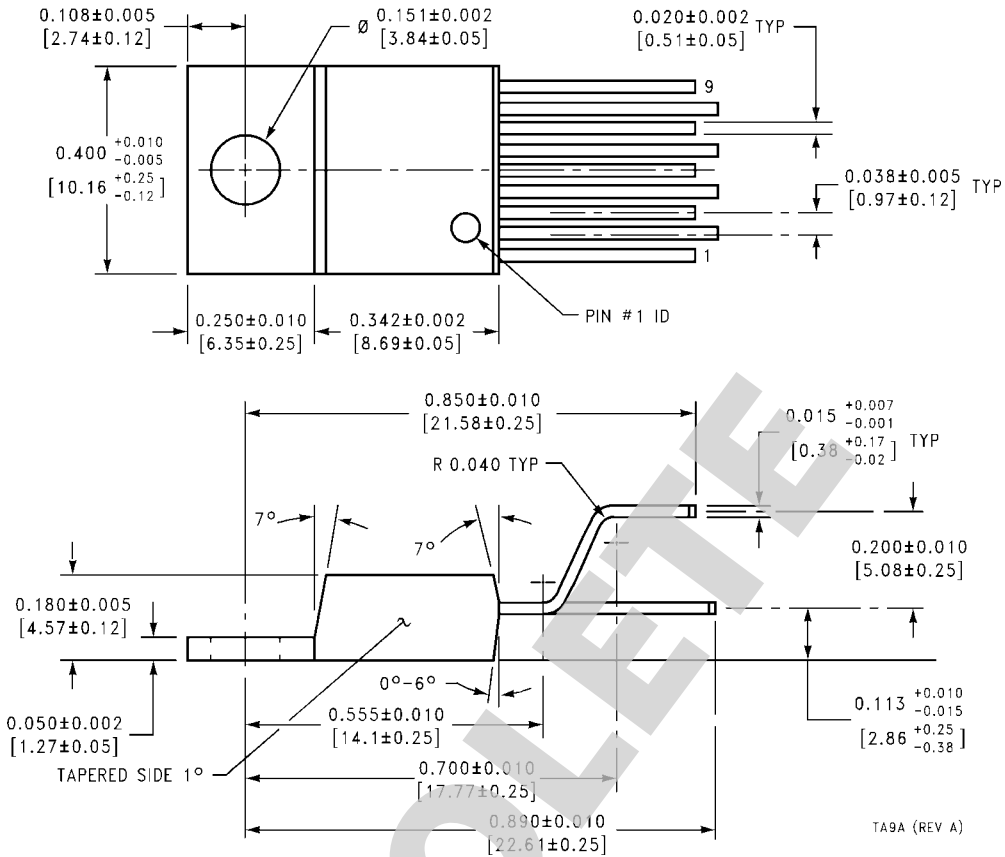

OBSOLETE

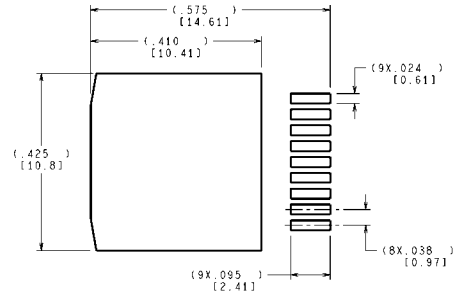
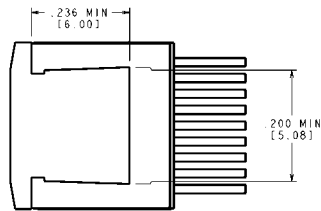
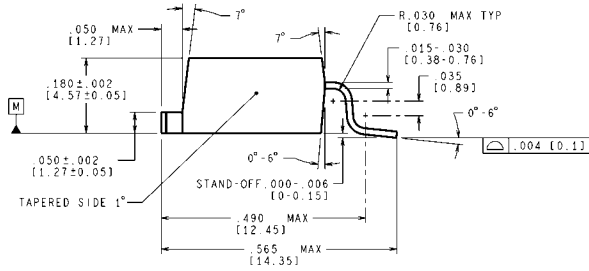
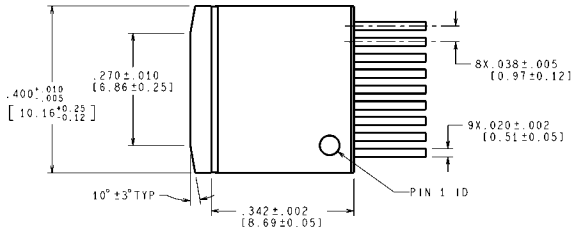

RECOMMENDED LAND PATTERN

CONTROLLING DIMENSION: INCH
DIMENSIONS IN [] ARE MILLIMETERS

Order Number LM9072S
NS Package Number TS9A

TS9A (Rev B)

OBSOLETE

Notes

LM9072

OBSOLETE

Notes

For more National Semiconductor product information and proven design tools, visit the following Web sites at:

Products		Design Support	
Amplifiers	www.national.com/amplifiers	WEBENCH® Tools	www.national.com/webench
Audio	www.national.com/audio	App Notes	www.national.com/appnotes
Clock and Timing	www.national.com/timing	Reference Designs	www.national.com/refdesigns
Data Converters	www.national.com/adc	Samples	www.national.com/samples
Interface	www.national.com/interface	Eval Boards	www.national.com/evalboards
LVDS	www.national.com/lvds	Packaging	www.national.com/packaging
Power Management	www.national.com/power	Green Compliance	www.national.com/quality/green
Switching Regulators	www.national.com/switchers	Distributors	www.national.com/contacts
LDOs	www.national.com/ldo	Quality and Reliability	www.national.com/quality
LED Lighting	www.national.com/led	Feedback/Support	www.national.com/feedback
Voltage Reference	www.national.com/vref	Design Made Easy	www.national.com/easy
PowerWise® Solutions	www.national.com/powerwise	Solutions	www.national.com/solutions
Serial Digital Interface (SDI)	www.national.com/sdi	Mil/Aero	www.national.com/milaero
Temperature Sensors	www.national.com/tempsensors	Solar Magic®	www.national.com/solarmagic
Wireless (PLL/VCO)	www.national.com/wireless	Analog University®	www.national.com/AU

THE CONTENTS OF THIS DOCUMENT ARE PROVIDED IN CONNECTION WITH NATIONAL SEMICONDUCTOR CORPORATION ("NATIONAL") PRODUCTS. NATIONAL MAKES NO REPRESENTATIONS OR WARRANTIES WITH RESPECT TO THE ACCURACY OR COMPLETENESS OF THE CONTENTS OF THIS PUBLICATION AND RESERVES THE RIGHT TO MAKE CHANGES TO SPECIFICATIONS AND PRODUCT DESCRIPTIONS AT ANY TIME WITHOUT NOTICE. NO LICENSE, WHETHER EXPRESS, IMPLIED, ARISING BY ESTOPPEL OR OTHERWISE, TO ANY INTELLECTUAL PROPERTY RIGHTS IS GRANTED BY THIS DOCUMENT.

TESTING AND OTHER QUALITY CONTROLS ARE USED TO THE EXTENT NATIONAL DEEMS NECESSARY TO SUPPORT NATIONAL'S PRODUCT WARRANTY. EXCEPT WHERE MANDATED BY GOVERNMENT REQUIREMENTS, TESTING OF ALL PARAMETERS OF EACH PRODUCT IS NOT NECESSARILY PERFORMED. NATIONAL ASSUMES NO LIABILITY FOR APPLICATIONS ASSISTANCE OR BUYER PRODUCT DESIGN. BUYERS ARE RESPONSIBLE FOR THEIR PRODUCTS AND APPLICATIONS USING NATIONAL COMPONENTS. PRIOR TO USING OR DISTRIBUTING ANY PRODUCTS THAT INCLUDE NATIONAL COMPONENTS, BUYERS SHOULD PROVIDE ADEQUATE DESIGN, TESTING AND OPERATING SAFEGUARDS.

EXCEPT AS PROVIDED IN NATIONAL'S TERMS AND CONDITIONS OF SALE FOR SUCH PRODUCTS, NATIONAL ASSUMES NO LIABILITY WHATSOEVER, AND NATIONAL DISCLAIMS ANY EXPRESS OR IMPLIED WARRANTY RELATING TO THE SALE AND/OR USE OF NATIONAL PRODUCTS INCLUDING LIABILITY OR WARRANTIES RELATING TO FITNESS FOR A PARTICULAR PURPOSE, MERCHANTABILITY, OR INFRINGEMENT OF ANY PATENT, COPYRIGHT OR OTHER INTELLECTUAL PROPERTY RIGHT.

LIFE SUPPORT POLICY

NATIONAL'S PRODUCTS ARE NOT AUTHORIZED FOR USE AS CRITICAL COMPONENTS IN LIFE SUPPORT DEVICES OR SYSTEMS WITHOUT THE EXPRESS PRIOR WRITTEN APPROVAL OF THE CHIEF EXECUTIVE OFFICER AND GENERAL COUNSEL OF NATIONAL SEMICONDUCTOR CORPORATION. As used herein:

Life support devices or systems are devices which (a) are intended for surgical implant into the body, or (b) support or sustain life and whose failure to perform when properly used in accordance with instructions for use provided in the labeling can be reasonably expected to result in a significant injury to the user. A critical component is any component in a life support device or system whose failure to perform can be reasonably expected to cause the failure of the life support device or system or to affect its safety or effectiveness.

National Semiconductor and the National Semiconductor logo are registered trademarks of National Semiconductor Corporation. All other brand or product names may be trademarks or registered trademarks of their respective holders.

Copyright© 2008 National Semiconductor Corporation

For the most current product information visit us at www.national.com



**National Semiconductor
Americas Technical
Support Center**
Email: support@nsc.com
Tel: 1-800-272-9959

**National Semiconductor Europe
Technical Support Center**
Email: europe.support@nsc.com
German Tel: +49 (0) 180 5010 771
English Tel: +44 (0) 870 850 4288

**National Semiconductor Asia
Pacific Technical Support Center**
Email: ap.support@nsc.com

**National Semiconductor Japan
Technical Support Center**
Email: jpn.feedback@nsc.com