

**RoHS compliant**

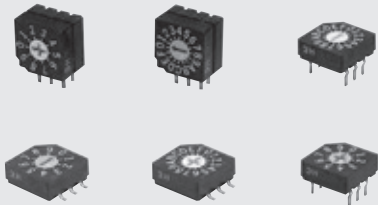

**INTERNAL STRUCTURE**  
SD-1000 / 2000 series

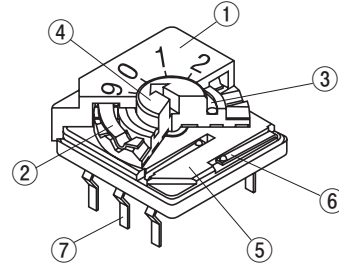

Part name	Material
① Housing	Polyphenylenesulfide
② Metallic	Stainless (SUS 301)
③ "O" ring	Silicone rubber
④ Insert rotor	Rotor : Polyamide Pattern : Copper alloy, Gold-plated
⑤ Base	Polyphenylenesulfide
⑥ Contact	Copper alloy, Gold-plated
⑦ Terminal pin	

**FEATURES**

- RoHS compliant
- Fine click with metallic spring
- Low profile of 3.9 mm makes perfect for high density board mounting applications
- Gold plated contact provides excellent reliability
- Cross and minus slot are available
- Terminal pin arrangement 3-3
- Resin material is UL Recognized 94V-0

**PART NUMBER DESIGNATION**

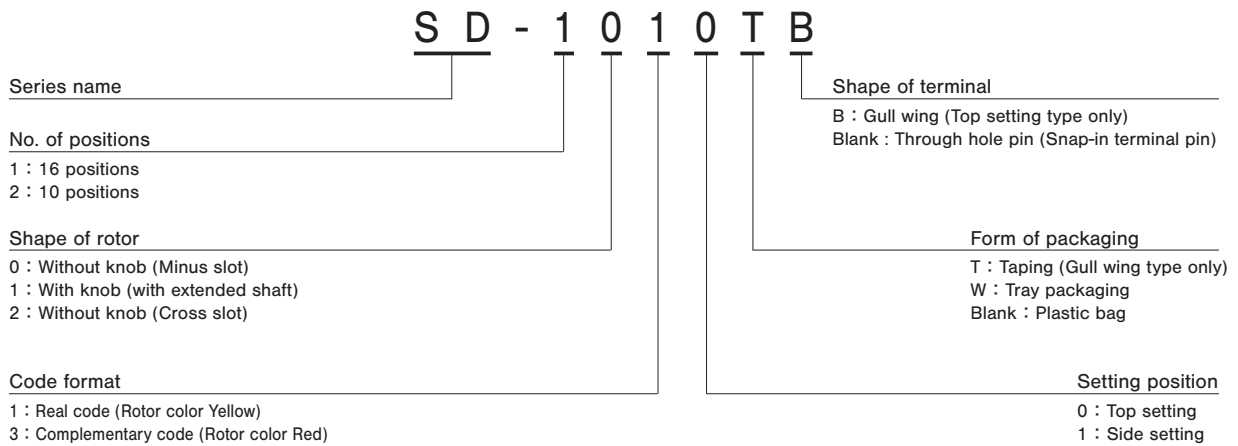

※ Please refer to the LIST OF PART NUMBERS when placing orders.

# SD-1000/2000

## ROTARY CODED SWITCHES

### LIST OF PART NUMBERS

#### Binary coded decimal

Shape of rotor		Form of packaging	Real code	Complementary code	Packaging quantity
Top setting (Through hole pin)	Without knob (Minus slot)	Plastic bag	SD-2010	SD-2030	25 pcs./pack
		Tray packaging	SD-2010W	SD-2030W	50 pcs./tray
	With knob	Plastic bag	SD-2110	SD-2130	25 pcs./pack
		Tray packaging	SD-2110W	SD-2130W	50 pcs./tray
	Without knob (Cross slot)	Plastic bag	SD-2210	SD-2230	25 pcs./pack
		Tray packaging	SD-2210W	SD-2230W	50 pcs./tray
Side setting (Through hole pin)	Without knob (Minus slot)	Plastic bag	SD-2011	SD-2031	25 pcs./pack
		Tray packaging	SD-2011W	SD-2031W	50 pcs./tray
	With knob	Plastic bag	SD-2111	SD-2131	25 pcs./pack
		Tray packaging	SD-2111W	SD-2131W	50 pcs./tray
	Without knob (Cross slot)	Plastic bag	SD-2211	SD-2231	25 pcs./pack
		Tray packaging	SD-2211W	SD-2231W	50 pcs./tray
Top setting (Gull wing)	Without knob (Minus slot)	Plastic bag	SD-2010B	SD-2030B	25 pcs./pack
		Tray packaging	SD-2010WB	SD-2030WB	50 pcs./tray
		Taping	SD-2010TB	SD-2030TB	500 pcs./reel
	Without knob (Cross slot)	Plastic bag	SD-2210B	SD-2230B	25 pcs./pack
		Tray packaging	SD-2210WB	SD-2230WB	50 pcs./tray
		Taping	SD-2210TB	SD-2230TB	500 pcs./reel

#### Binary coded hexadecimal

Shape of rotor		Form of packaging	Real code	Complementary code	Packaging quantity
Top setting (Through hole pin)	Without knob (Minus slot)	Plastic bag	SD-1010	SD-1030	25 pcs./pack
		Tray packaging	SD-1010W	SD-1030W	50 pcs./tray
	With knob	Plastic bag	SD-1110	SD-1130	25 pcs./pack
		Tray packaging	SD-1110W	SD-1130W	50 pcs./tray
	Without knob (Cross slot)	Plastic bag	SD-1210	SD-1230	25 pcs./pack
		Tray packaging	SD-1210W	SD-1230W	50 pcs./tray
Side setting (Through hole pin)	Without knob (Minus slot)	Plastic bag	SD-1011	SD-1031	25 pcs./pack
		Tray packaging	SD-1011W	SD-1031W	50 pcs./tray
	With knob	Plastic bag	SD-1111	SD-1131	25 pcs./pack
		Tray packaging	SD-1111W	SD-1131W	50 pcs./tray
	Without knob (Cross slot)	Plastic bag	SD-1211	SD-1231	25 pcs./pack
		Tray packaging	SD-1211W	SD-1231W	50 pcs./tray
Top setting (Gull wing)	Without knob (Minus slot)	Plastic bag	SD-1010B	SD-1030B	25 pcs./pack
		Tray packaging	SD-1010WB	SD-1030WB	50 pcs./tray
		Taping	SD-1010TB	SD-1030TB	500 pcs./reel
	Without knob (Cross slot)	Plastic bag	SD-1210B	SD-1230B	25 pcs./pack
		Tray packaging	SD-1210WB	SD-1230WB	50 pcs./tray
		Taping	SD-1210TB	SD-1230TB	500 pcs./reel

※ Verify the above part numbers when placing orders.

※ Taping and tray version can be supplied only in reel or tray units.

# SD-1000/2000

## ROTARY CODED SWITCHES

### STANDARD SPECIFICATIONS

Circuit type	BCD (Real code, complementary code) BCH (Real code, complementary code)
Operating temp. range	- 40 ~ 85 °C
Storage temp. range	
Sealing	Non-washable
Net weight	Without knob Top setting 0.65 g With knob Top setting 0.76 g Without knob Side setting 0.95 g With knob Side setting 1.05 g

### ELECTRICAL CHARACTERISTICS

Contact rating Non-switching Switching Minimum	DC50 V 100 mA DC5 V 100 mA DC20 mV 1 μA
Contact resistance	100 mΩ maximum
Insulation resistance	1000 MΩ (DC100 V) minimum
Dielectric strength	AC250 V, 60 s

### ENVIRONMENTAL CHARACTERISTICS

Vibration	(Amplitude) 1.5 mm or (Acceleration) 98 m/s <sup>2</sup> , 10-500-10 Hz, 3 directions for 2 h each
Shock	490 m/s <sup>2</sup> , 11 ms 6 directions for 3 times each
Humidity	Resistance load DC50V 100mA 40 °C, Relative humidity 90 ~ 95 %, 240 h
Load life	20000 steps DC5 V, 100 mA
High temp. exposure	85 °C, 96 h
Low temp. exposure	-40 °C, 96 h
Thermal shock	-40 (0.5 h) ~ 85 °C (0.5 h), 5 cycles

### MECHANICAL CHARACTERISTICS

No. of positions	16 (SD-1000), 10 (SD-2000)	
Adjustment torque	4 ~ 25 mN·m {41 ~ 255 gf·cm}	
Stepping angle	22.5° (SD-1000), 36° (SD-2000)	
Terminal strength (Through hole pin only)	10 N {1.02 kgf} minimum	
Stop strength (With knob only)	10 N {1.02 kgf}, 10 s	
Solderability	245 ± 3 °C, 2 ~ 3 s	
Soldering heat	Gull wing	Reflow : Peak temperature 255 °C (Please refer to the profile below.)
	Through hole pin	Flow : 260 ± 3 °C as the temperature in a pot of molten solder, immersion from head of terminal to backside of board 5 ~ 6 s, two times maximum  Manual soldering : 380 ± 10 °C, 3 ~ 4 s
Shear (Gull wing only)	5 N {0.51 kgf} 10 s	
Substrate bending (Gull wing only)	Width 90 mm, bend 3 mm, 5 s, 1 time	
Pull-off strength (Gull wing only)	5 N {0.51 kgf} 10 s	

### Reflow profile for soldering heat evaluation

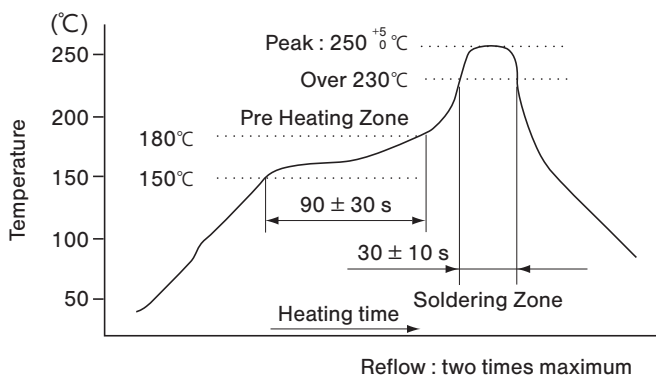

{ } : Reference only

# SD-1000/2000

## ROTARY CODED SWITCHES

### OUTLINE DIMENSIONS

Unless otherwise specified, tolerance:  $\pm 0.3$  (Unit: mm)

#### <Through hole pin, Top setting>

- SD-1010 (Real code)
- SD-1030 (Complementary code)

- SD-2010 (Real code)
- SD-2030 (Complementary code)

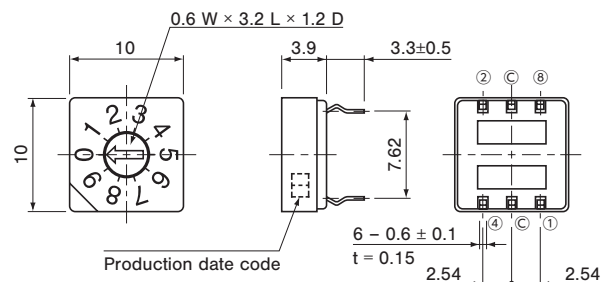
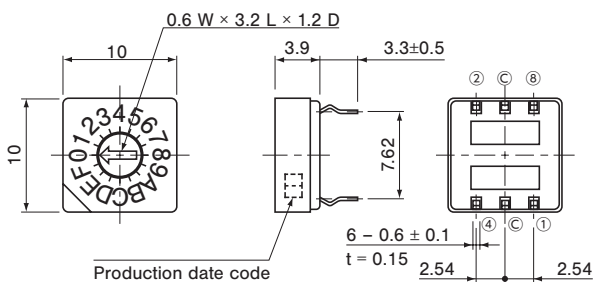

- SD-1210 (Real code)
- SD-1230 (Complementary code)

- SD-2210 (Real code)
- SD-2230 (Complementary code)

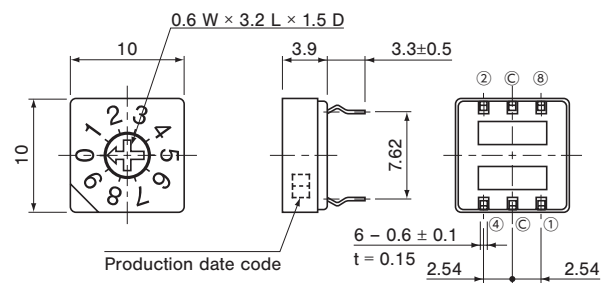
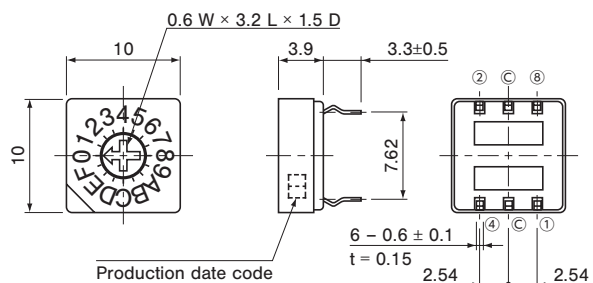

- SD-1110 (Real code)
- SD-1130 (Complementary code)

- SD-2110 (Real code)
- SD-2130 (Complementary code)

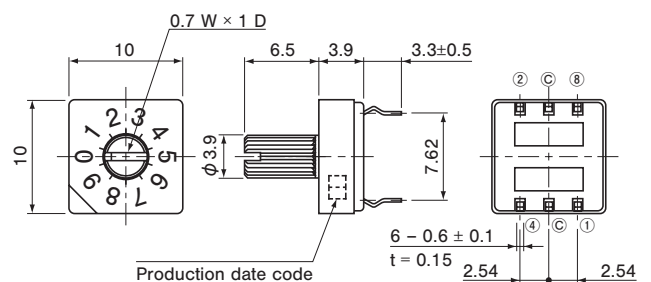
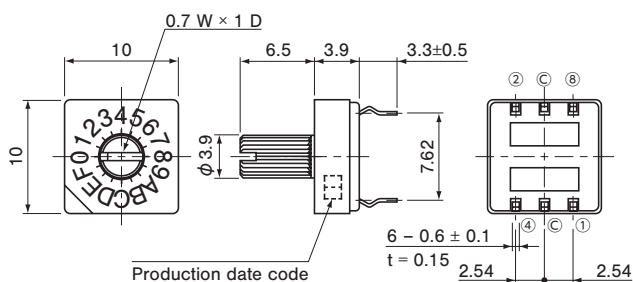

# SD-1000/2000

## ROTARY CODED SWITCHES

### OUTLINE DIMENSIONS

Unless otherwise specified, tolerance:  $\pm 0.3$  (Unit: mm)

#### <Through hole pin, Side setting>

- SD-1011 (Real code)
- SD-1031 (Complementary code)

- SD-2011 (Real code)
- SD-2031 (Complementary code)

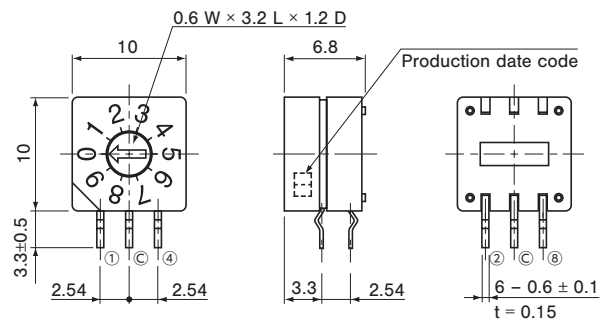
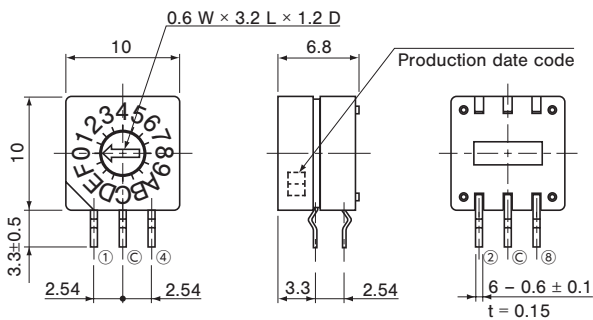

- SD-1211 (Real code)
- SD-1231 (Complementary code)

- SD-2211 (Real code)
- SD-2231 (Complementary code)

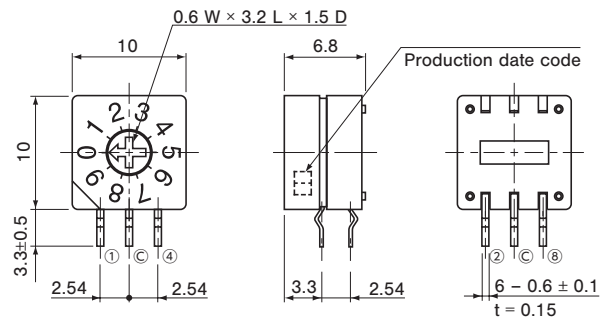
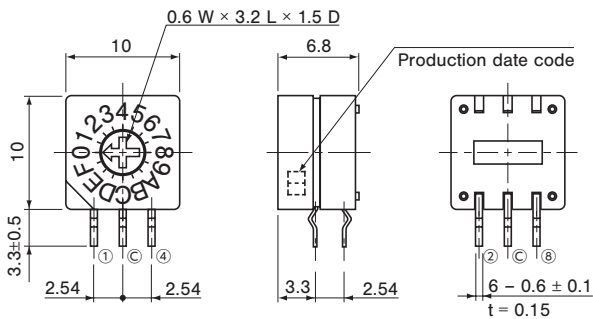

- SD-1111 (Real code)
- SD-1131 (Complementary code)

- SD-2111 (Real code)
- SD-2131 (Complementary code)

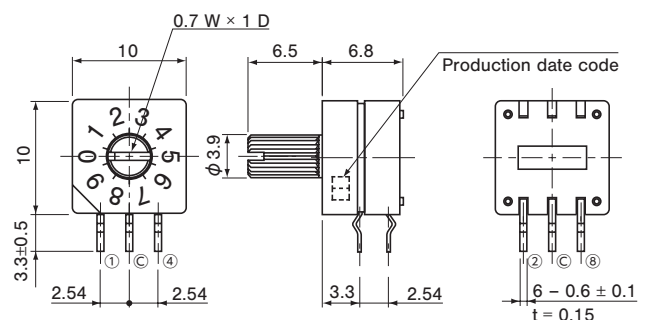
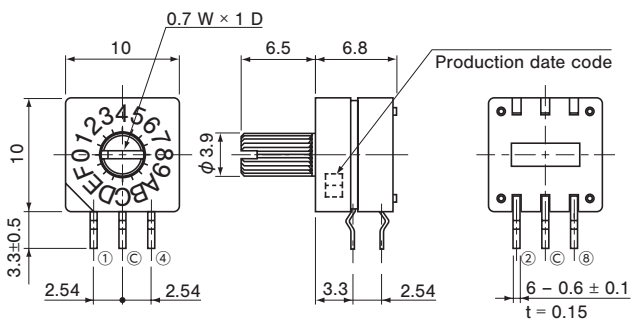

# SD-1000/2000

## ROTARY CODED SWITCHES

### OUTLINE DIMENSIONS

Unless otherwise specified, tolerance:  $\pm 0.3$  (Unit: mm)

#### <Gull wing, Top setting>

- SD-1010B (Real code)
- SD-1030B (Complementary code)

- SD-2010B (Real code)
- SD-2030B (Complementary code)

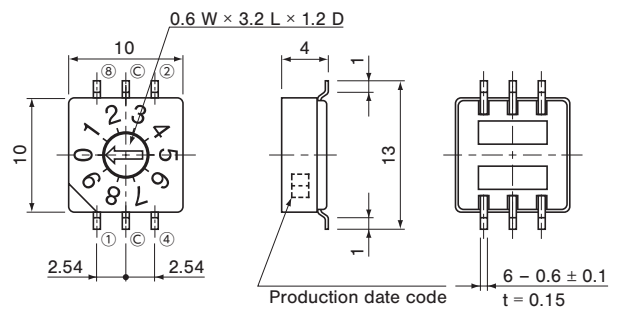
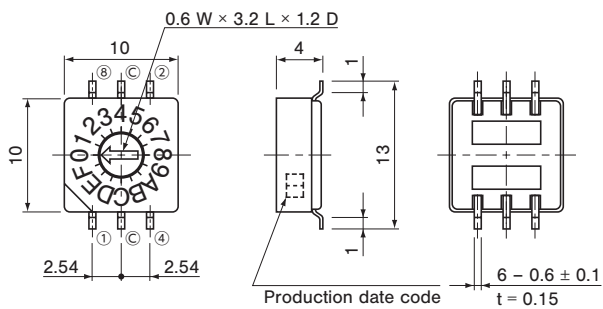

- SD-1210B (Real code)
- SD-1230B (Complementary code)

- SD-2210B (Real code)
- SD-2230B (Complementary code)

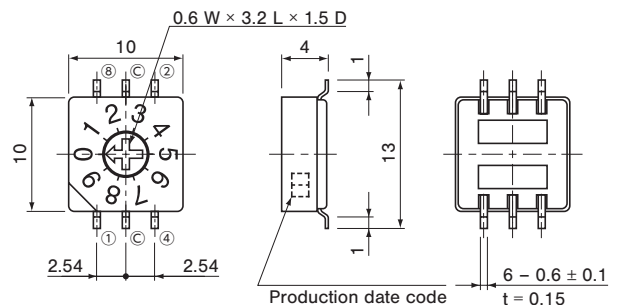
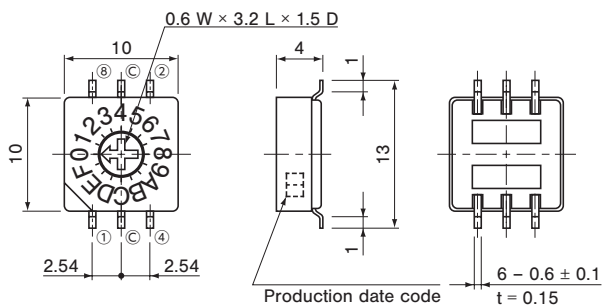

# SD-1000/2000

## ROTARY CODED SWITCHES

### CODE FORMAT

No. of positions		SD-1000 series (16 positions)																
		SD-2000 series (10 positions)																
Position		0	1	2	3	4	5	6	7	8	9	A	B	C	D	E	F	
Code	Real code	8								●	●	●	●	●	●	●	●	
		4				●	●	●	●						●	●	●	●
		2			●	●			●	●			●	●			●	●
	Complementary code	8	●	●	●	●	●	●	●	●								
		4	●	●	●	●					●	●	●	●				
		2	●	●			●	●			●	●			●	●		
	1	●		●		●		●		●		●		●		●		

● ...Contact closed

### TERMINAL CONNECTION / P.C.B. THROUGH HOLE DIMENSIONS

(Unit: mm)

	Top setting	Side setting
Terminal pin layout (Bottom view)	<div style="display: flex; justify-content: space-around;"> <div style="text-align: center;">Real code</div> <div style="text-align: center;">Complementary code</div> </div>	<div style="display: flex; justify-content: space-around;"> <div style="text-align: center;">Operating face of real code</div> <div style="text-align: center;">Operating face of complementary code</div> </div>
P.C.B. dimensions (Bottom view)		

### RECOMMENDED P.C.B. PAD OUTLINE DIMENSIONS

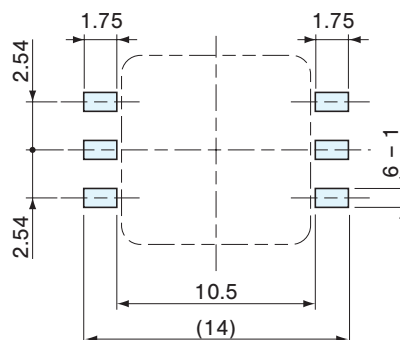

# SD-1000/2000

## ROTARY CODED SWITCHES

### PACKAGING SPECIFICATIONS

#### <Taping packaging specifications>

- Taping version is packaged in 500 pcs. per reel.  
Orders will be accepted for units of 500 pcs., i.e., 500, 1000, 1500 pcs., etc.
- Taping version is boxed with one reel (500 pcs.).

Maximum number of consecutive missing pieces=2

Leader length and reel dimension are shown in the dia-grams below:

#### ● Embossed tape dimensions

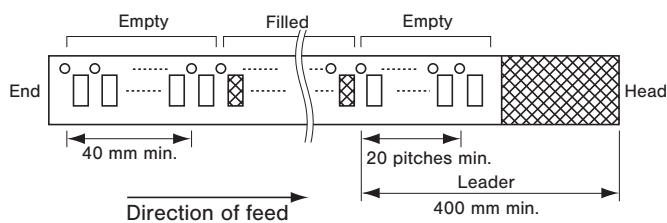

#### ● Reel dimensions

(In accordance with EIAJ ET-7200A)

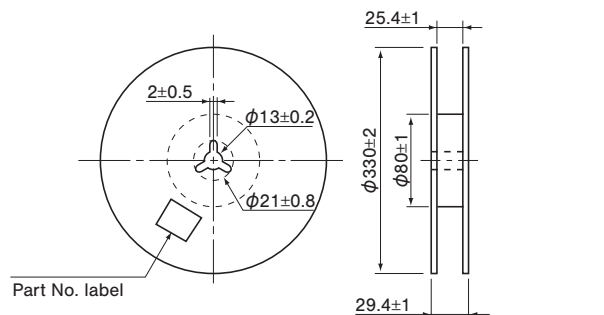

(Unit: mm)

(Unit: mm)

(In accordance with EIAJ RC-1009B)

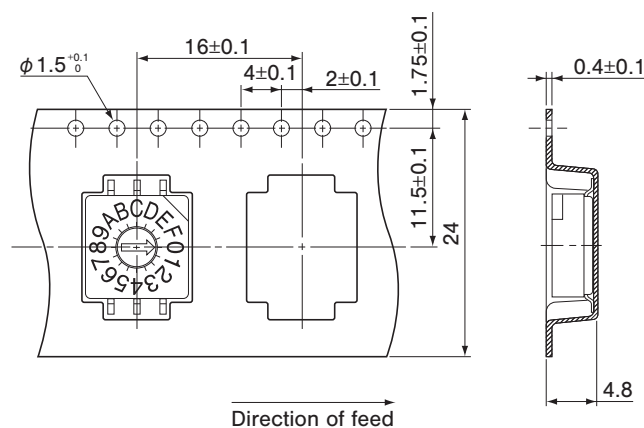

#### <Tray packaging specifications>

- Tray version is packaged in 50 pcs. per tray. Orders will be accepted for units of 50 pcs., i. e., 50, 100, 150 pcs. etc.
- Tray version is boxed with 10 trays.

#### <Bulk pack specifications>

- The smallest unit of bulk pack in a plastic bag is 10 pcs. per pack. Orders will be accepted for unit of minimum 10 pcs., i.e., 10, 20, 30 pcs., etc.
- Boxing of bulk in a plastic bag is performed with 25 pcs. (standard 50 pcs.) per box.