

Direct drive digital position indicator



• Base and case

High-resistance polyamide based (PA) technopolymer.
Resistant to solvents, oils, greases and other chemical agents.
Black base.

Case in the following colours:

- **C2**: RAL 2004 orange, glossy finish.
- **C3**: RAL 7035 grey, glossy finish.

On request and for a quantity of at least 10 pieces, it is available in RAL 7021 (C1) grey-black.

The ultrasonically welding between the base and the case prevents separation and avoids dust penetration.

• Window

Transparent polyamide based (PA-T) technopolymer, moulded over the case and with a perfect seal. Resistant to solvents, oils, greases and other chemical agents (avoid contact with alcohol during cleaning operations).

• Display

It indicates the displacement of the mechanism controlled by the spindle from the start position (0).

Five-digit roller counter (four black rolls and one red roll or three black rolls and two red rolls). The digits of red rolls show the decimal values. An additional graduated scale next to the last decimal digit offers further accuracy of reading.

The display can be in different positions (see "Guide to the choice of standard combinations").

- **AN**: inclined display, counter in upper position.
- **AR**: inclined display, counter in lower position.
- **FN**: front display, counter in upper position.
- **FR**: front display, counter in lower position.

• Internal gasket

O-ring front sealing in NBR synthetic rubber, between the case and the bushing.

• Rear gasket

Foam polyethylene, supplied.

• Standard executions

Black-oxide steel with $\varnothing 20$ mm H7 reamed hole, fitting to shaft by means of a supplied grub screw with hexagon socket and cup end.

- **DD52R**: black-oxide steel bushing.
- **DD52R-SST**: AISI 303 stainless steel bushing.

• Direction of rotation

- **D**: clockwise. Increasing values with clockwise rotation of the bushing.
- **S**: anti-clockwise. Increasing values with anti-clockwise rotation of the bushing.

• Weight

96 grams.

Special executions on request

- Special readings after one revolution.
- Case in different colours.
- Completely sealed digital position indicators with IP 67 protection class, see IEC 529 table (see Catalogue 151 Technical data page A25), obtained by means of a brass bushing with double seal ring inside the rear cavity of the base.

Features and applications

Lowered direct drive digital position indicators can be assembled on passing through spindles in any position to give direct reading of the positioning of a machine component. They are suitable also for motor driven applications (see "Guide to the choice of standard combinations").

Ergonomics and design

Compact roller counter. Ergonomically designed digits for rapid reading. The readability of the counter is increased by the magnifying window.

Assembly instructions

1. Drill a $\varnothing 6$ mm \times 10 mm hole in the body of the machine with a 30 mm centre distance from the spindle to fit the rear referring pin.
2. Set the spindle to the start or referring position.
3. Fit the indicator with the zeroed roller counter onto the spindle and make sure that the referring pin fit the hole.
4. Clamp the bushing to the spindle by tightening the grub screw with hexagon socket and cup end, according to UNI 5929-85.

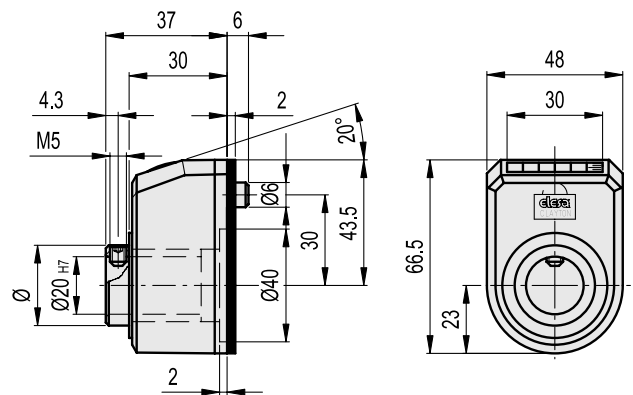



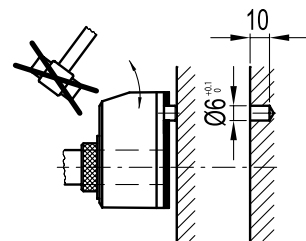
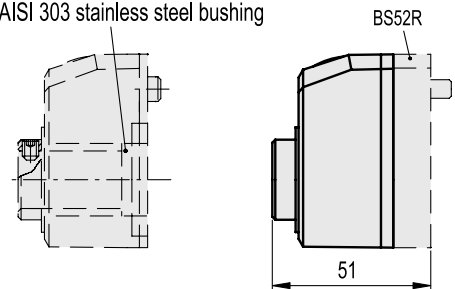





special execution with AISI 303 stainless steel bushing

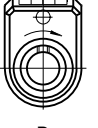

Guide to the choice of standard combinations

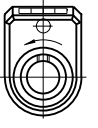
Order description

DD52R	-	AN	-	0 0 0 5 0	-	D	-	C2	-	SST
Series		Display position		Reading after one revolution		Direction of rotation		Colour		Stainless steel boss
 AN inclined upper 2		 AR inclined lower		The internal mechanism counts also the figures between brackets (even if they do not appear on the display).		 D clockwise		 C2 RAL 2004		 SST To add only for the version with stainless steel boss
 FN front upper		 FR front lower				 S anti-clockwise		 C3 RAL 7035		
								 C1 RAL 7021		

0 0 0 0 5		0 0 0 5 0	Pitch	Speed (rpm) *
0000.5	000.05	00005	0.5	1500
0000.9(6)	000.09(6)	00009(6)	0.9	1500
0001.0	000.10	00010	1.0	1500
0001.2(5)	000.12(5)	00012(5)	1.25	1500
0001.5	000.15	00015	1.5	1500
0001.5(8)	000.15(8)	00015(8)	1.58	1500
0001.6(07)	000.16(07)	00016(07)	1.607	1500
0001.7(5)	000.17(5)	00017(5)	1.75	1420
0002.0	000.20	00020	2.0	1250
0002.5	000.25	00025	2.5	1000
0002.5(4)	000.25(4)	00025(4)	2.54	980
0003.0	000.30	00030	3.0	830
0003.1(5)	000.31(5)	00031(5)	3.15	790
0003.1(75)	000.31(75)	00031(75)	3.175	780
0003.5	000.35	00035	3.5	710
0004.0	000.40	00040	4.0	625
0005.0	000.50	00050	5.0	500
0005.0(8)	000.50(8)	00050(8)	5.08	490
0005.2(94)	000.52(94)	00052(94)	5.294	470
0005.6(47)	000.56(47)	00056(47)	5.647	440
0006.0	000.60	00060	6.0	415
0006.2(5)	000.62(5)	00062(5)	6.25	400
0006.3(5)	000.63(5)	00063(5)	6.35	390
0007.0	000.70	00070	7.0	350
0007.5	000.75	00075	7.5	330
0008.0	000.80	00080	8.0	315
0009.0	000.90	00090	9.0	270
0010.0	001.00	00100	10.0	250
0010.5	001.05	00105	10.5	235
0011.9(05)	001.19(05)	00119(05)	11.905	210
0012.0	001.20	00120	12.0	200
0013.0	001.30	00130	13.0	190
0015.0	001.50	00150	15.0	160
0016.0	001.60	00160	16.0	150
0020.0	002.00	00200	20.0	125

* The maximum rotation speed (rpm) of the spindle reported in the table corresponds to a maximum rotation speed of 25000 units per minute of the last roll on the right side of the counter.
 Rotational speed tests have been performed in our laboratory under standard operating conditions.



Accessories on request (to be ordered separately)

- **BSA52**: zinc die-cast bases for spindle locking, epoxy resin coating, black colour, matte finish (see table). Type GN 302 adjustable handle. BSA52 locking bases allow an easy and quick locking of the spindles after their positioning. They are equipped with a $\varnothing 6.1$ mm hole to fit the referring pin of the indicator. They can be assembled with the handle either on the right or on the left and can be fitted to the machine by means of two M5 cylindrical-head screws (not included in the supply).

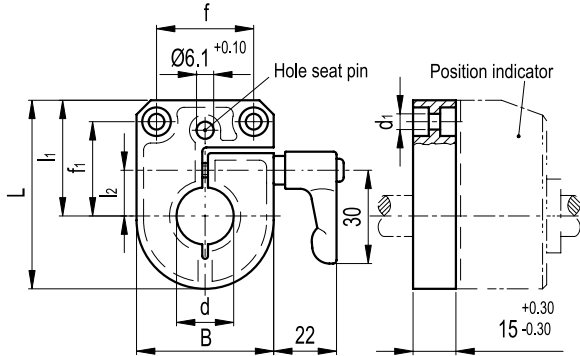

BSA52		Main dimensions							Mounting hole		Δ
Code	Description	B	L	d1	f	f1	l1	l2	d	g	
CE.87901	BSA52-12	48	66.5	5.5	34	33.6	43.1	16	12	165	
CE.87903	BSA52-14	48	66.5	5.5	34	33.6	43.1	16	14	164	
CE.87904	BSA52-15	48	66.5	5.5	34	33.6	43.1	16	15	163	
CE.87905	BSA52-16	48	66.5	5.5	34	33.6	43.1	16	16	162	
CE.87909	BSA52-20	48	66.5	5.5	34	33.6	43.1	16	20	160	

- **RB52**: black-oxide steel reduction sleeves (see table).
- **RB52-SST**: AISI 303 stainless steel reduction sleeves (see table).

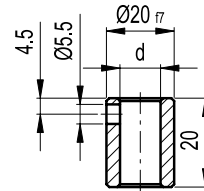

RB52		Mounting hole	
Code	Description	d H7	
CE.87940	RB52-12	12	
CE.87950	RB52-14	14	
CE.87955	RB52-15	15	
CE.87960	RB52-16	16	

INOX
Stainless Steel

RB52-SST		Mounting hole	
Code	Description	d H7	
CE.97940	RB52-12 -SST	12	
CE.97950	RB52-14 -SST	14	
CE.97955	RB52-15 -SST	15	
CE.97960	RB52-16 -SST	16	

- **BS52R**: glass-fibre reinforced polyamide based (PA) technopolymer spacer base (code CE.83950), designed with two pre-drilled holes for UNI 10227 self-tapping screws $\varnothing 2.2$ (not included in the supply).

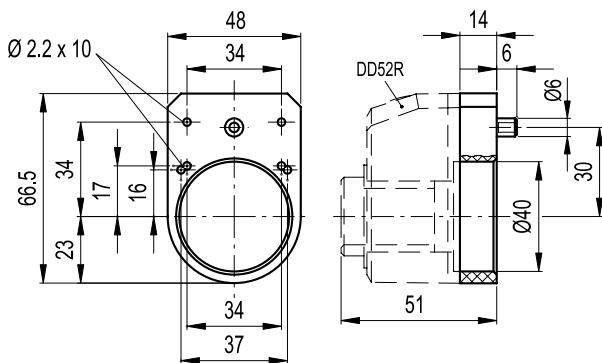

- **PE.6-10**: red technopolymer pin (code CE.83960).

