



4.3" Touchscreen HMI



- Security, Datalogging
- Trends, Plots
- Pass through mode
- Macros
- Serial & Ethernet

EasyAccess2.0  

System	CPU	32-bit RISC Cortex-A8, 600 MHz
	Memory (RAM)	128 MB
	Memory (Flash)	128 MB
	RTC	Built-in
I/O Ports	Serial	1 x DE9P COM1: RS-232/RS-485 2 or 4 wire, COM 3: RS-485 2 wire
	LAN	1 x 10/100 Base-T RJ-45
	CANbus	N/A
	USB Host	1 x USB 2.0
	USB Client	N/A
	Audio	N/A
	Video	N/A
	Wi-Fi	N/A
	HDMI®	N/A
	SD Card Slot	N/A
	Display	Display Type
Size (W x H)		3.74 x 2.13 inches [95 x 54 mm]
Resolution (pixels)		480 x 272
Max. Colors		16.7 M
Luminance (cd/m²)		400
Viewing Angle (H°/V°)		140/120
Contrast Ratio		500:1
Backlight Lifetime (hours)	30,000+	
Touch Screen	Type	4-wire resistive touch
	Active Area Accuracy	Length (X) ±2%, width (Y) ±2%
Electrical	Input Voltage	10.5 ~ 28 VDC
	Input Current	800 mA @ 12 VDC, 400 mA @ 24 VDC
	Input Power	9.6 W
	Power Isolation	Built-in
	Isolation Resistance	Exceed 50 MΩ at 500 VDC
Mechanical	Enclosure	Plastic, charcoal grey
	PCB Coating	N/A
	Dimensions (W x H x D)	5.04 x 4.02 x 1.26 inches [128 x 102 x 32 mm]
	Net Weight	Approx. 0.55 lbs. [0.25 kg]
	Mounting	Panel mounting
Environmental	Operating Temperature	32° ~ 122°F (0° ~ 50°C)
	Storage Temperature	-4° ~ 140°F (-20° ~ 60°C)
	Relative Humidity	10% ~ 90% (non-condensing)
	Vibration Endurance	10 to 25 Hz (X, Y, Z direction, 2G, 30 minutes)
	Ratings	NEMA 4, IP65 compliant front panel
Certifications	CE, RoHS	
Software	EBPro (v6.00.01.174 or later), Modbus, VNC Server	
Notes	Specifications subject to change without notice	

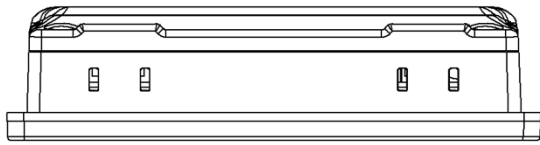

Top View

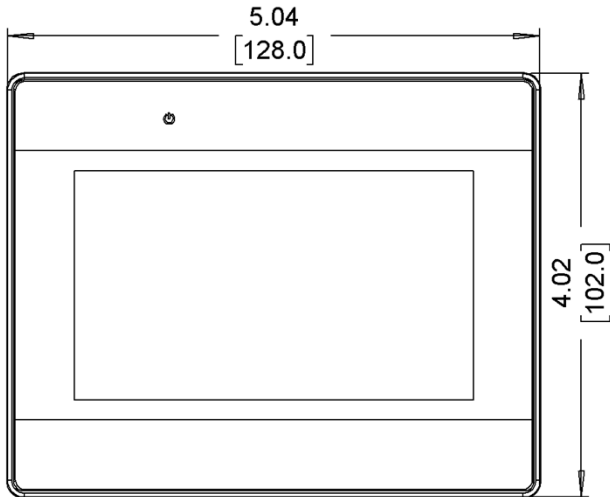

Front View

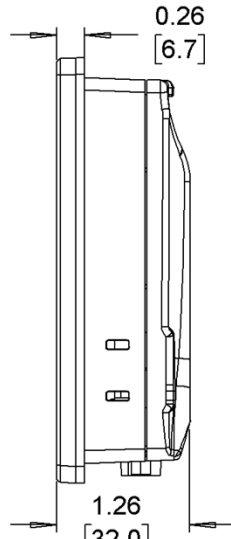

Side View

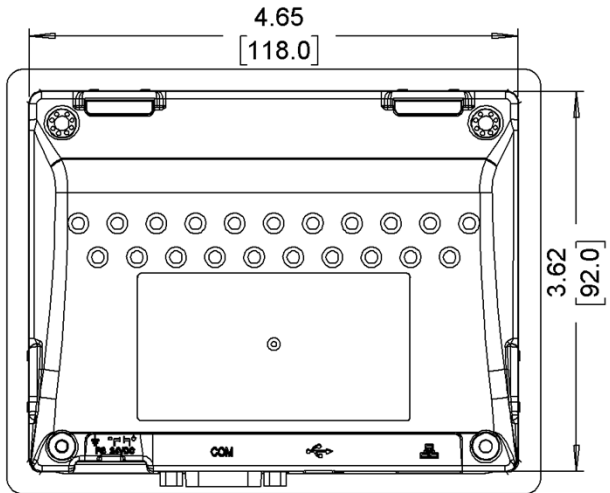

Rear View

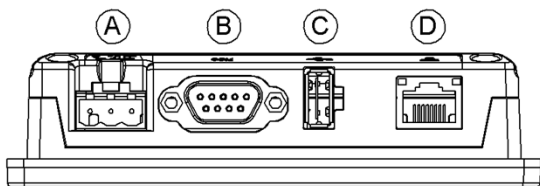

Bottom View

Dimensions are in inches [mm]

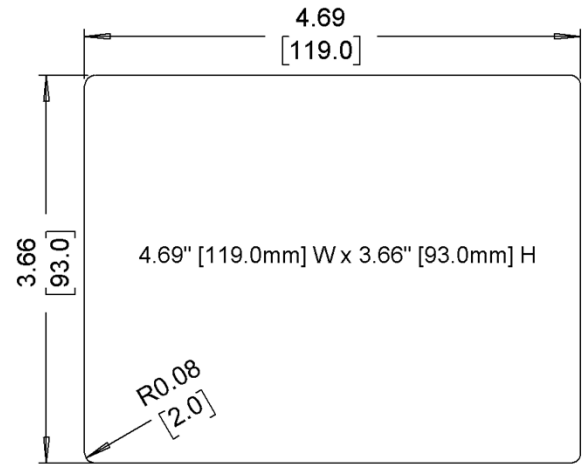

Cutout Dimensions

- A Power Connector
- B COM Port DE9P
- C USB 2.0 Host Port
- D Ethernet Port