

SF

HIGH PERFORMANCE SWITCH MODE EMI FILTER

FEATURES

- » **Rated currents include 3A, 5A, 7.5A, 10A, 15A, 20A, 24A, 30A, 45A and 60A**
- » Available with **QD** (tabs), **S** (studs) and **C** (connectors) option
- » End Mount, Low Profile, Connector & Flange Mount Available
- » Agency Approved to UL E78081, CSA LR53652, TUV
- » Y-cap value can be adjusted to fit specification

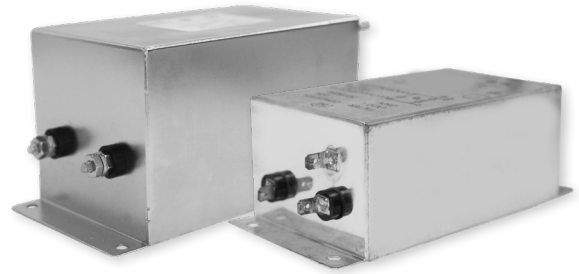

ELECTRICAL SCHEMATIC

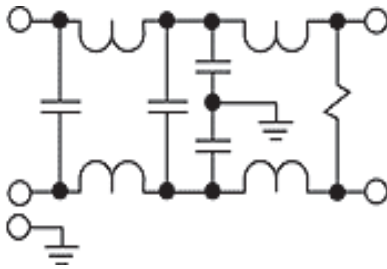

SPECIFICATIONS

OPERATING FREQUENCY	50/60Hz
MAX. OPERATING VOLTAGE	250VAC +10%
TERMINALS (-T)	QD: 0.25 TABS STUDS: 8-32 (1-5A), 10-32(10-45A) 1/4-20 (60A)
TYP. WEIGHT, LBS (KG)	0.36 - 10.7 (0.16 - 4.85)

LEAKAGE CURRENT	
@ 250 VAC 60 Hz	0 - 2.1 mA Max.

HIPOT RATINGS	
LINE TO GROUND	2200 VDC - 2700 VDC

TYPICAL APPLICATIONS

- ✓ Household Appliances
- ✓ Industrial Equipment
- ✓ Switch Mode Power Supplies
- ✓ Consumer Electronics
- ✓ Office Automation Equipment
- ✓ Data Processing Systems

HOW TO ORDER

SF XX LF

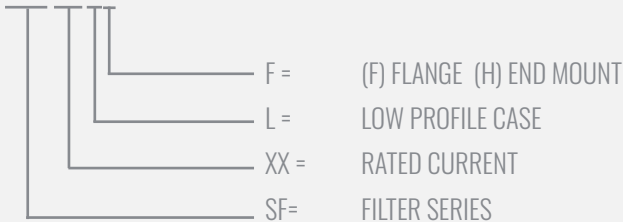

NOTE: USE ANY COMBINATION OF -X (AMPS) WITH ANY -Y RATINGS
E.G. **SF24 LF**(24 AMPS, LOW PROFILE CASE, FLANGE MOUNT)

SF

HIGH PERFORMANCE SWITCH MODE EMI FILTER

MODEL NO.	RATED CURRENT (A) @ 40° C	Y-CAP, nF	LEAKAGE CURRENT, mA @ 250V AC, 60 Hz	TERMINAL OPTIONS			MAX. DIMENSIONS" (MM)		
				(QD) INPUT/ OUTPUT	(S) INPUT/ OUTPUT	(C) INPUT/ OUTPUT	WIDTH	(LENGTH)	HEIGHT
SF3 S	3	2x.0047µF	*			✓	2"	*	1.25"
SF3C	3	2x.0047µF	.80			✓	2.03"	3.1"	1.5"
SF3C S	3	2x.0047µF	.80			✓	2.03"	3.13"	1.5"
SF3	3	2x.0047µF	.80	✓			2.03"	3.2"	1.25"
SF5C	5	*	*			✓	*	*	*
SF7C	7.5	2x.0047µF	.8			✓	2.15"	3.47"	1.75"
SF7C S	7.5	2x.0047µF	.8			✓	2.15"	3.5"	1.75"
SF7	7.5	2x.0047µF	.80	✓			2.03"	3.7"	1.5"
SF7 S	7.5	2x.0047µF	.80		✓		2.03"	3.76"	1.5"
SF10	10	2x.0047µF	.80	✓			2.15"	4.07"	1.78"
SF10 S	10	2x.0047µF	.80		✓		2.15"	4.13"	1.78"
SF15	15	2x.0047µF	.80	✓			2.91"	4.26"	2"
SF15L	15	2x.0047µF	.80	✓			2.05"	6.44"	1.5"
SF15 S	15	2x.0047µF	.80		✓		2.91"	4.32"	2"
SF15L S	15	2x.0047µF	.80		✓		2.05"	6.5"	1.5"
SF15A	15	2x.0047µF/2x .0022µF	1.2	✓			2.91"	4.26"	2"
SF20	20	2x.0047µF	.80		✓		4.12"	5.17"	1.5"
SF20A	20	2x.0047µF/2x .0022µF	1.1		✓		4.12"	5.17"	1.5"
SF20L	20	2x.0068µF	.9		✓		2.05"	6.5"	1.5"
SF20AL	20	2x.0068µF/2x .0033µF	1.2		✓		2.05"	6.5"	1.5"
SF24 LF	24	2x.0068µF	1.0		✓		4.25"	8.11"	2.25"
SF24L	24	2x.0068µF	1.0		✓		3.06"	6.26"	2.25"
SF24 LH	24	*	1.0				*	*	*
SF30 F	30	2x.01µF	1.4		✓		3"	5.51"	2.75"
SF30A F	30	2x.01µF/2x .0047µF	2.1		✓		3"	6.11"	2.75"
SF30	30	*	1.4				*	*	*
SF45 F	45	2x.01µF	1.4		✓		3"	8.86"	2.75"
SF45 H	45	2x.01µF	1.4		✓		3"	8.86"	2.75"
SF45A H	45	2x.01µF/2x .0047µF	2.1		✓		3"	8.86"	2.75"
SF45	45	*	1.4				*	*	*
SF60 F	60	2x.01µF/2x .001µF	1.6		✓		4"	9.24"	4"
SF60	60	*	1.6				*	*	*

*Contact factory for part data.

SF

HIGH PERFORMANCE SWITCH MODE EMI FILTER

SF MECHANICAL OUTLINES (MM)

QD TABS (3A)

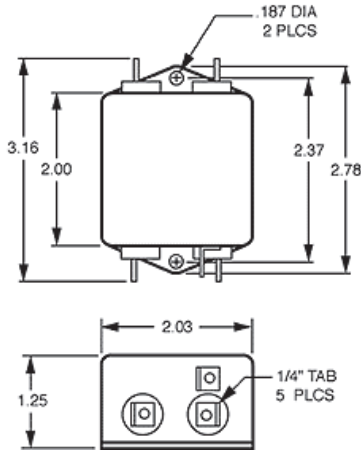

QD TABS (7.5A)

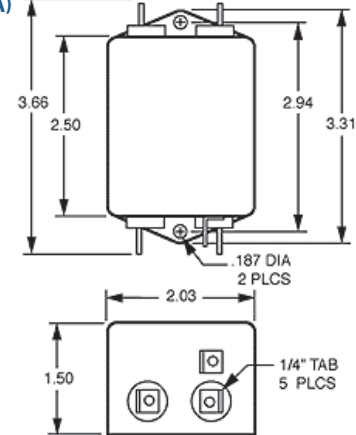

QD TABS (10A)

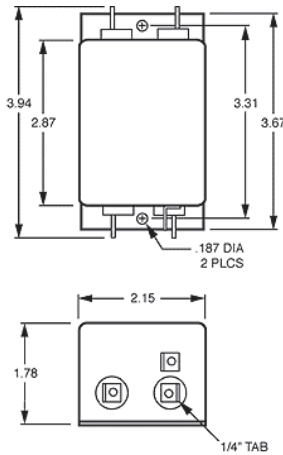

QD TABS (15A)

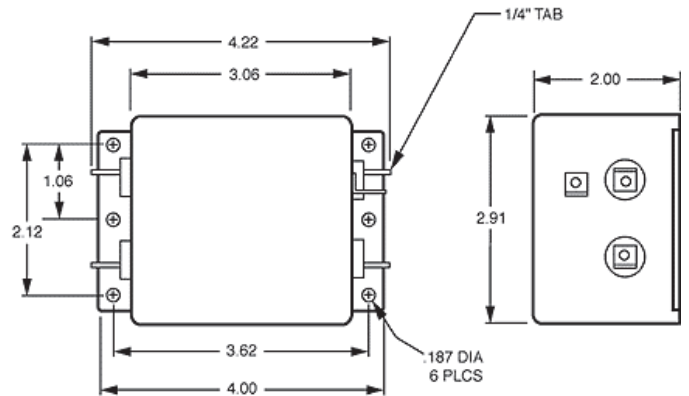

QD TABS (15A) LOW PROFILE

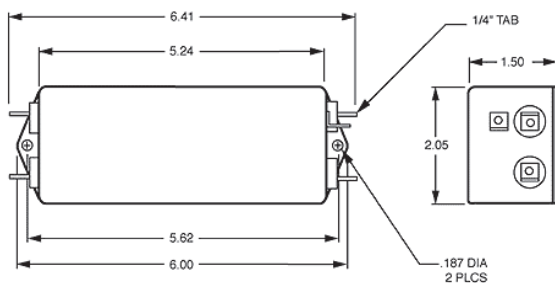

STUDS (20A)

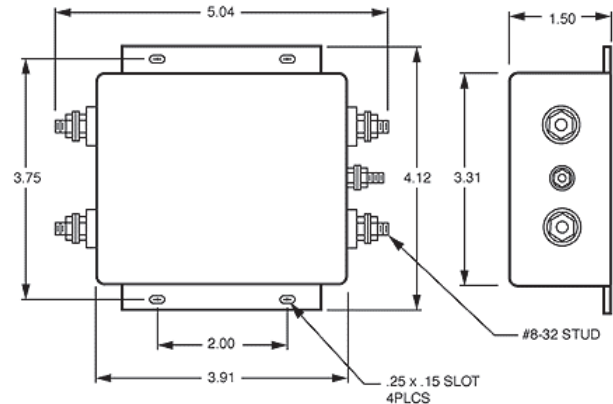

SF

HIGH PERFORMANCE SWITCH MODE EMI FILTER

STUDS (20A) LOW PROFILE

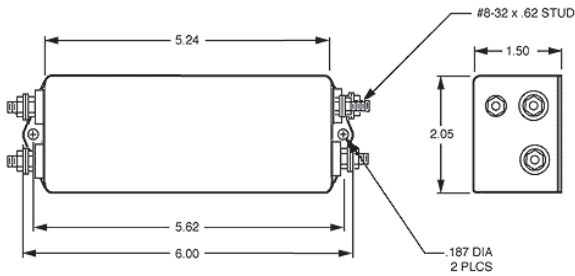

STUDS (24A)

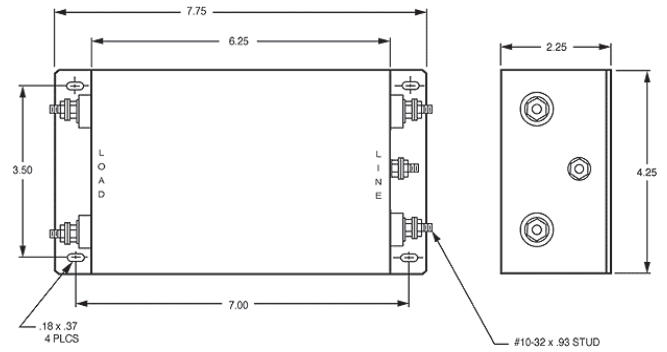

STUDS (24A) LOW PROFILE

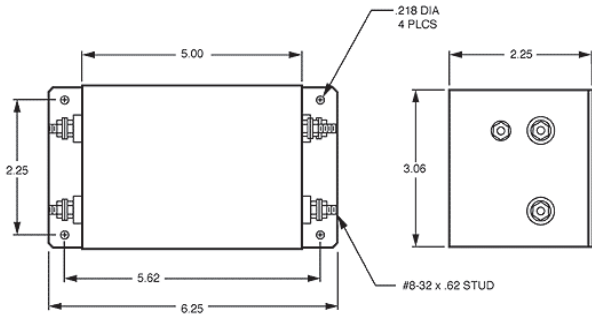

STUDS (30A)

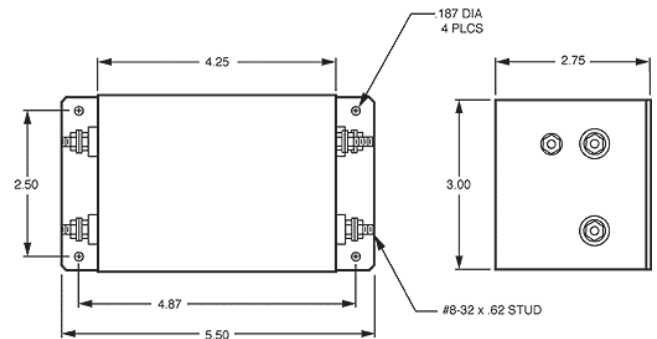

STUDS (45A)

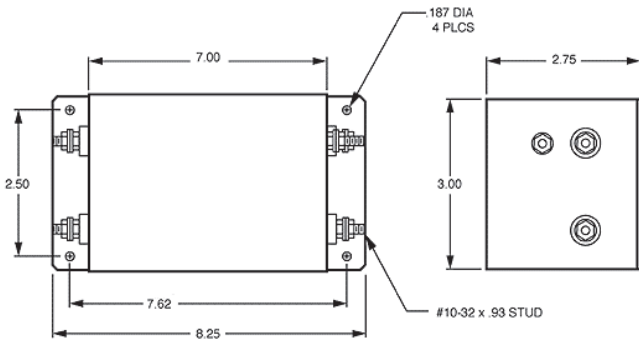

STUDS (45A) LOW PROFILE

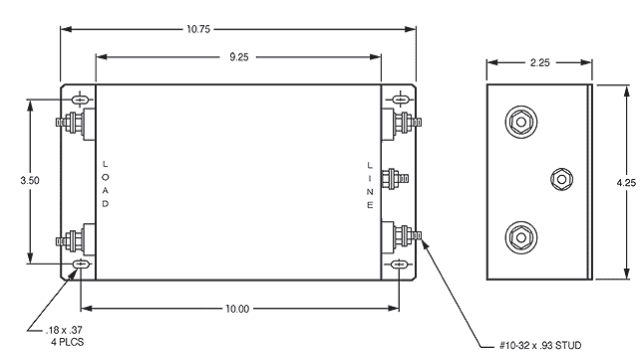

TYPICAL TOLERANCE: +/-0.02" (0.50MM)

SF

HIGH PERFORMANCE SWITCH MODE EMI FILTER

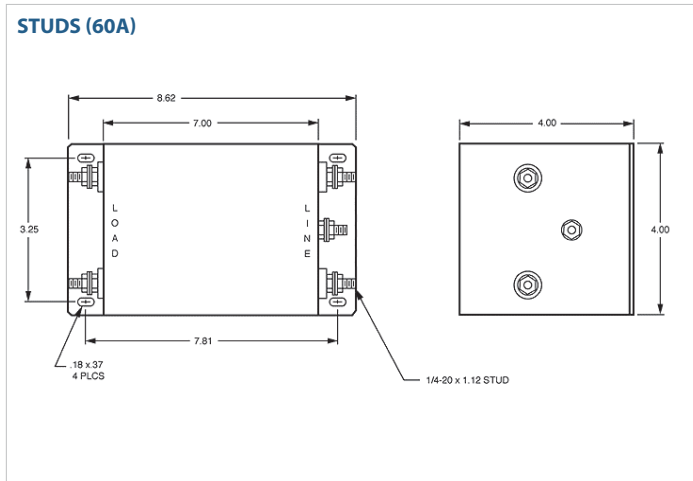

TYPICAL TOLERANCE: +/-0.02" (0.50MM)

TYPICAL INSERTION LOSS, dB (50/50 Ohm)

Amps	Freq (MHz)	0.15	0.5	1.0	10	30
3	CM (dB)	45	60	51	67	74
	DM (dB)	45	65	52	69	78
5	CM (dB)	45	60	51	67	74
	DM (dB)	45	65	52	69	78
7.5	CM (dB)	30	60	51	67	74
	DM (dB)	45	65	52	69	78
10	CM (dB)	45	50	51	67	74
	DM (dB)	45	65	52	69	78
15	CM (dB)	50	60	51	67	74
	DM (dB)	42	65	52	69	78
20	CM (dB)	45	60	51	67	74
	DM (dB)	43	65	52	69	78
24	CM (dB)	45	60	51	67	74
	DM (dB)	45	60	52	69	78
30	CM (dB)	50	65	51	67	74
	DM (dB)	45	65	52	69	78
45	CM (dB)	45	55	51	67	74
	DM (dB)	45	60	52	69	78
60	CM (dB)	45	60	51	67	74
	DM (dB)	45	65	52	69	78