

GN 374 Flat springs

for control mechanisms GN 264 and GN 268

VL.140+I Control handwheels

with revolving handle, Duroplast

- 1
- 2
- 3
- 4
- 5
- 6
- 7
- 8
- 9
- 10
- 11
- 12
- 13
- 14
- 15
- 16
- 17
- 18



MATERIAL
Steel.

FEATURES AND APPLICATIONS

GN 374 flat springs are an excellent and practical element for connecting GN 264 (see page 704) graduated rings, shafts and flanges GN 268 (see page 705). The assembly with these flanges creates the control mechanism as shown in the drawing.

When the operator sets the shaft, the flat springs guarantee the movement of the graduated ring without the possibility of the same ring to rotate when the shaft does not turn.

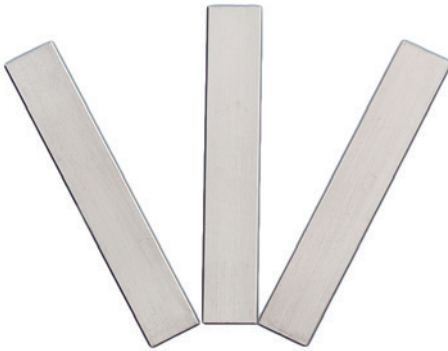

Control mechanisms composition

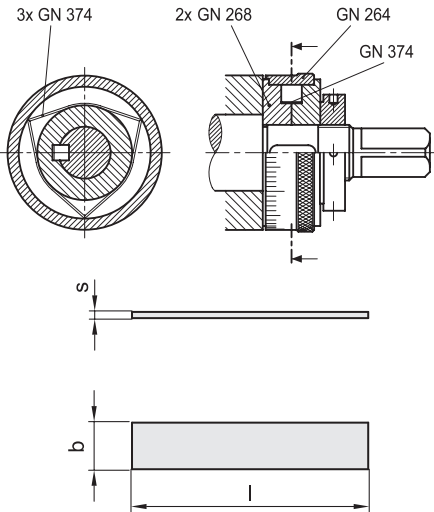

		METRIC			
Code	Description	s	b	l	
GN.26276	GN 374-0.3-10	0.3	10	21	1
GN.26277	GN 374-0.4-10	0.4	10	29	1
GN.26278	GN 374-0.6-10	0.6	10	45	3
GN.26279	GN 374-0.8-10	0.8	10	60	4



MATERIAL

Phenolic based (PF) Duroplast, black colour, glossy finish.

REVOLVING HANDLE

l.281+x (see page 662) in Duroplast.

STANDARD EXECUTION

Black-oxide steel hub, with pre-drilled blind hole.



ELESA Original design

Conversion Table	
1 mm = 0.039 inch	
D	
mm	inch
82	3.23
99	3.90
129	5.08

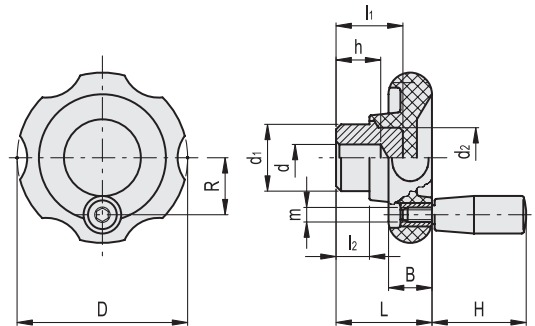

		METRIC													
Code	Description	D	dH9	d-0.1	L	B	l1	l2	d1	d2	h	H	M	R	
74431	VL.140/80+I	82	-	6	40	19	23	12	24	20	15	40	M6	26	180
74521	VL.140/100+I	99	8	-	44	20	31	14	36	30	22	50	M8	32	385
74621	VL.140/130+I	129	8	-	47	22	30	13	40	40	20	65	M8	43	585