

PART NO.

RFD-4195-HPL

REV	DESCRIPTION	DWN	DATE	APPROVED
-	ENGINEERING RELEASE	CZS	08/14/14	JDMc

ASSEMBLY INSTRUCTIONS:

- Step 1: Cut end of cable evenly. Strip cable to dimensions as shown. All cuts are to be clean and square. Do not nick center conductor when cutting. If using heat shrink tubing slide onto cable first.
- Step 2: Slide spacer and pin onto cable center conductor until it yields against the cable dielectric. Solder pin in place.
- Step 3: Insert the pin into the body until it yields against the back of the connector. Solder connector and cable outer conductor in place.

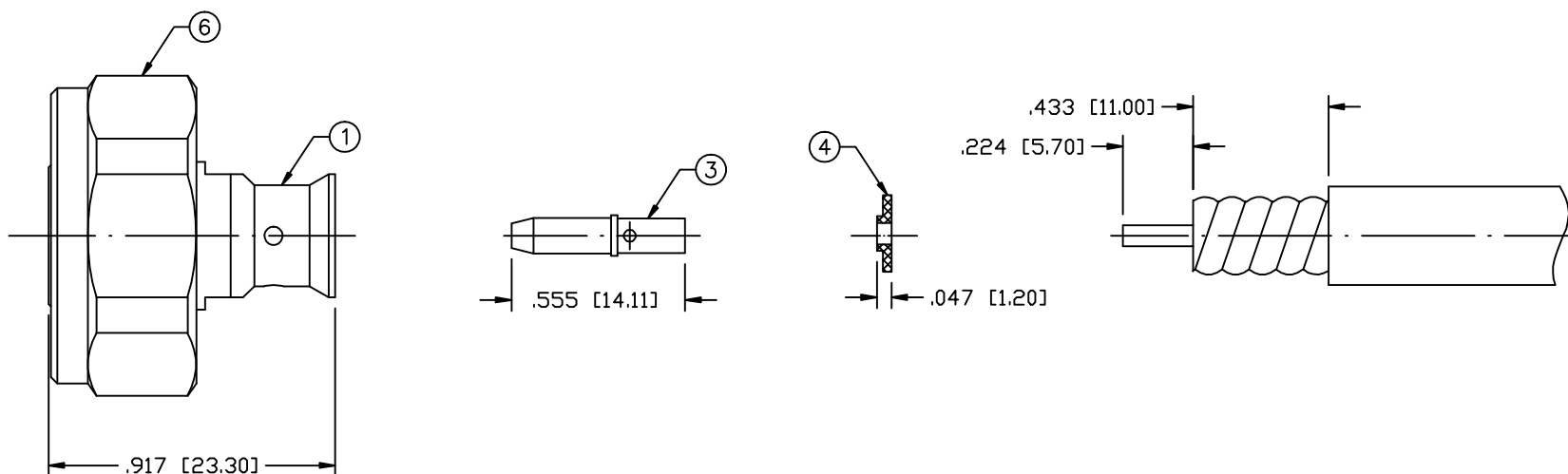

SPECIFICATIONS:

IMPEDANCE: 50 Ohms
 FREQUENCY RANGE: 0-3 GHz
 VSWR: <1.2:1 THRU 3GHz
 INSERTION LOSS: >-.1dB
 PIM: ≤-155 dBc
 TEMPERATURE RANGE: -55°C TO 200°C
 FOR SPP-250-LLPL

6	SHELL	1	BRASS	WHITE BRONZE
5	O-RING	1	SILICONE	----
4	SPACER	1	PTFE	----
3	PIN	1	BRASS	SILVER
2	INSULATOR	1	PTFE	----
1	BODY	1	BRASS	WHITE BRONZE
#	DESCRIPTION	QTY	MATERIAL	FINISH

CUSTOMER OUTLINE DRAWING	
ALL DIMENSIONS ARE REFERENCE ONLY	
UNLESS OTHERWISE SPECIFIED: DIMENSIONS ARE IN INCHES AND [MILLIMETERS]	
DRAWN C. ZUNIGA	10/27/16
CHECKED	
ORJ DRAWN C. ZUNIGA	08/14/14

R O H S
COMPLIANT

PROPRIETARY AND CONFIDENTIAL
 THIS DRAWING CONTAINS
 INFORMATION PROPRIETARY TO
 RF INDUSTRIES. ANY
 UNAUTHORIZED USE OF THIS
 DRAWING IS EXPRESSLY
 PROHIBITED WITHOUT WRITTEN
 PERMISSION FROM RF
 INDUSTRIES. ANY VIOLATION IS
 PUNISHABLE UNDER U.S.
 COPYRIGHT LAWS.

RFconnectors
 DIVISION OF RF INDUSTRIES, LTD. (858) 549-6345 FAX
 7610 MIRAMAR RD.
 SAN DIEGO, CA 92126
 (858) 549-6340

4.1/9.5 PLUG, SOLDER FOR SPP-250

SIZE A	CABLE GROUP N/A	DWG NO. RFD-4195-HPL	REV ---
SCALE: NTS	ENGINEERING ID: 000000	SHEET 1 OF 1	