

STRAIGHT BULKHEAD JACK FULL CRIMP

R125.313.120

CABLE 2.6/50 D

Series : FOR SMA

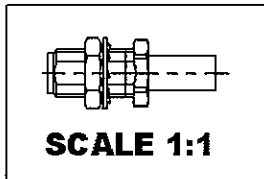
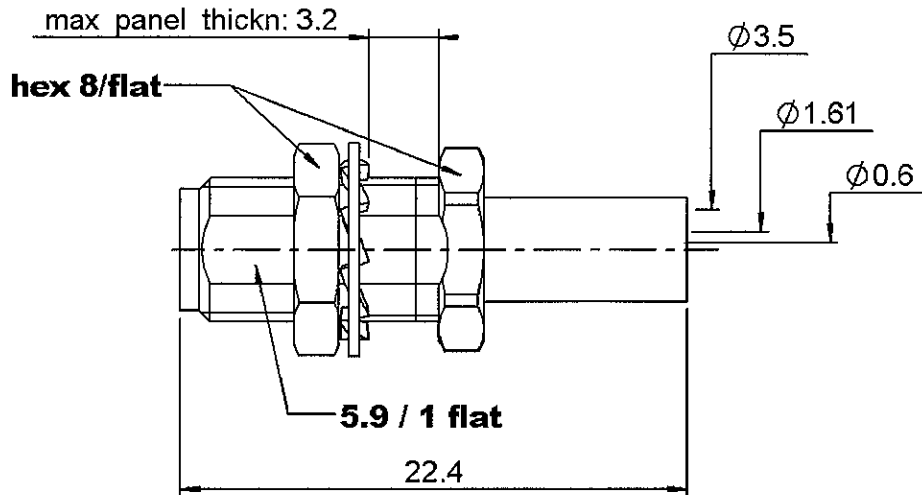

PANEL CUT OUT

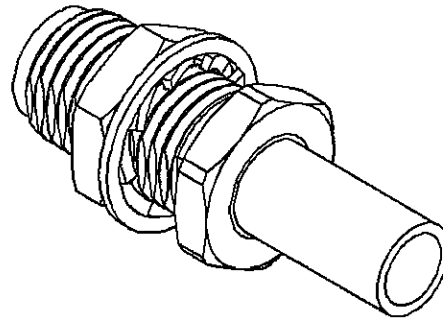
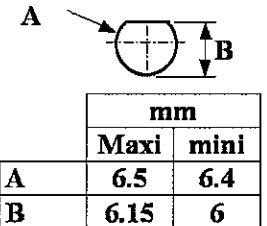

All dimensions are in mm.

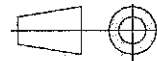

COMPONENTS	MATERIALS	PLATINGS (µm)
BODY	STAINLESS STEEL	GOLD 0.5 OVER NICKEL 2
CENTER CONTACT	BERYLLIUM COPPER	GOLD 1.3 OVER NICKEL 2
OUTER CONTACT	-	-
INSULATOR	PTFE	-
GASKET	-	-
OTHERS PARTS	BRASS	GOLD 0.2 OVER NICKEL 2
-	-	-
-	-	-

Issue : 0539 B

In the effort to improve our products, we reserve the right to make changes judged to be necessary.



STRAIGHT BULKHEAD JACK FULL CRIMP

R125.313.120

CABLE 2.6/50 D

Series : FOR SMA

PACKAGING

Standard	Unit	Other
100	'W' option	Contact us

SPECIFICATION

ELECTRICAL CHARACTERISTICS

Impedance		50 Ω
Frequency		0-12.4 GHz
VSWR	1.15 +	0.020 x F(GHz) Maxi
Insertion loss		0.05 √F(GHz) dB Maxi
RF leakage	- (- F(GHz)) dB Maxi
Voltage rating		250 Veff Maxi
Dielectric withstanding voltage		750 Veff mini
Insulation resistance		5000 MΩ mini

CABLE ASSEMBLY

Stripping mm	a	b	c	d	e	f
	3.00	6.30	10.8	0.00	7.80	0.00

Assembly instruction : **Crimp 01**

Recommended cable(s)
RD 316
K02252D

N

Characteristics indicated on this data sheet are those that can be achieved with the highest performance cable. Intrinsic limitations of the cable may diminish the performance of the assembly

Cable retention

- pull off **110** N mini
- torque - N.cm

MECHANICAL CHARACTERISTICS

Center contact retention		
Axial force – Mating end	18	N mini
Axial force – Opposite end	18	N mini
Torque	NA	N.cm mini

TOOLING

Part Number	Description	Hexagon
.	.	.
R282.281.000	CRIMPING TOOL	2X4 CC
R282.967.012	POSITONER FOR CRIMPING TOOL	Pos.5
. And - (et)		
R282.271.000	CRIMPING TOOL	3.84 (fer)
. Or - (ou)		
R282.293.000	CRIMPING TOOL	
R282.235.037	CRIMPING DIES	3.84 (fer)

Recommended torque		
Mating	NA	N.cm
Panel nut	150	N.cm
Clamp nut	NA	N.cm
A/F clamp nut	0.000	mm

Mating life	500	Cycles mini
Weight	3.420	g

ENVIRONMENTAL

Operating temperature	-65/+165	° C
Hermetic seal	NA	Atm.cm3/s
Panel leakage	NA	

OTHERS CHARACTERISTICS

Issue : 0539 B

In the effort to improve our products, we reserve the right to make changes judged to be necessary.



RADIALL®