

# Collaborative Robots

# TM5

## Collaborative robot for assembly, packaging, inspection and logistics

- Designed to promote a safe and harmonious workplace between humans and machines.
- Easy-to-use graphical programming environment for quick startup and operation.
- Built-in vision-based robot control enables visual serving, inspection, and measurement operations.
- TMvision and landmark allows truly flexible, fast changeover.
- Plug & Play ecosystem provides the tools and versatility for many manufacturing needs.
- Capability to integrate with mobile robots enables fully autonomous machine tending and logistics handling applications.

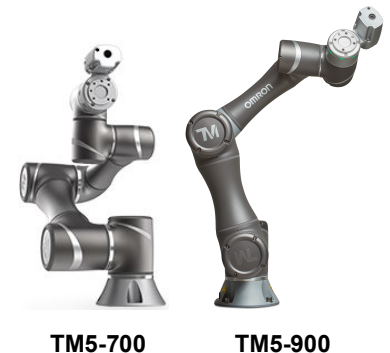

## Specification

		TM5					
Product Name		TM5-700	TM5M-700	TM5M-700 SEMI	TM5-900	TM5M-900	TM5M-900 SEMI
Weight (kg)		22.1			22.6		
Controller Weight (kg)		13.5	14.5	14.5	13.5	14.5	14.5
Max Payload (kg)		6			4		
Reach (mm)		700			900		
Mounting		Wall, Table, Ceiling					
Typical Speed (m/s)		1.1			1.4		
Joint Range	Joint 1	±270°					
	Joint 2, 4, 5	±180°					
	Joint 3	±155°					
	Joint 6	±270°					
Joint Speeds	Joint 1, 2, 3	180°/s					
	Joint 4, 5, 6	225°/s					
Repeatability (mm)		±0.05					
IP		IP54 (robot arm), IP32 (control box), IP40 (robot stick)					
Cleanroom Class		ISO Class 5					
Food Grade Grease Version		Yes	No	No	Yes	No	No
Operating Temperature and Humidity		0 to 50°C, 85% max. (with no condensation)					
Storage Temperature and Humidity		-20 to 60°C, 75% max. (with no condensation)					
Operating and Storage Atmosphere		No corrosive gases or exposure to water-soluble cutting oil*					
Power Supply		100-240 VAC, 50-60 Hz	22-60 VDC	22-60 VDC	100-240 VAC, 50-60 Hz	22-60 VDC	22-60 VDC
Robot Arm Cable Length		3m/12m	1.5m	1.5m	3m/12m	1.5m	1.5m
I/O Ports	Control Box	Digital In: 16 Digital Out: 16 Analog In: 2 Analog Out: 1					
	Tool	Digital In: 4 Digital Out: 4 Analog In: 1 Analog Out: 0					
I/O Interface		3 X COM, 1 X HDMI, 3 X LAN, 4 X USB2.0, 2 X USB3.0					
Communication		RS232, Ethernet (master), Modbus TCP/RTU (master & slave), Optional Fieldbus (EtherNet/IP or PROFINET)					
Integrated Camera		5M pixels, color	5M pixels, color	5M pixels, color	5M pixels, color	5M pixels, color	5M pixels, color
I/O Power Supply		24V 1.5A (control box and tool)					
Programming Environment		TMflow, flowchart based					
SEMI S2 Certified*		No	No	Yes	No	No	Yes

\* SEMI safety SEMI safety guidelines are issued by an industry association with the same name: SEMI (Semiconductor Equipment and Materials International), which is the central global network of manufacturers of micro- and nano-electronics industries.

\* SEMI S2 is the most well-known standard in semiconductor manufacturing equipment for Environmental, Health, and Safety (EHS).

\* If water-soluble cutting oil is present, use a protective sleeve to prevent damage to the robot housing. OMRON offers enhanced joint covers for these applications. Contact your local OMRON representative for more information.

# Collaborative Robots TM12/14

## Collaborative robot for assembly, packaging, inspection and logistics

- Designed to promote a safe and harmonious workplace between humans and machines.
- Easy-to-use graphical programming environment for quick startup and operation.
- Built-in vision-based robot control enables visual serving, inspection, and measurement operations.
- TMvision and landmark allows truly flexible, fast changeover.
- Plug & Play ecosystem provides the tools and versatility for many manufacturing needs.
- Capability to integrate with mobile robots enables fully autonomous machine tending and logistics handling applications.



TM12

TM14

## Specifications

		TM12			TM14		
Product Name		TM12	TM12M	TM12M SEMI	TM14	TM14M	TM14M SEMI
Weight (kg)		33.3			32.6		
Controller Weight (kg)		13.8	14.5	14.5	13.8	14.5	14.5
Max Payload (kg)		12			14		
Reach (mm)		1300			1100		
Mounting		Wall, Table, Ceiling					
Typical Speed (m/s)		1.3			1.1		
Joint Range	Joint 1	±270°					
	Joint 2, 4, 5	±180°					
	Joint 3	±166°			±163°		
	Joint 6	±270°					
Joint Speeds	Joint 1, 2	120°/s					
	Joint 3	180°/s					
	Joint 4, 5	180°/s			150°/s		
	Joint 6	180°/s					
Repeatability (mm)		±0.1					
IP		IP54 (robot arm), IP32 (control box), IP40 (robot stick)					
Cleanroom Class		ISO Class 5					
Food Grade Grease Version		Yes	No	No	Yes	No	No
Operating Temperature and Humidity		0 to 50°C, 85% max. (with no condensation)					
Storage Temperature and Humidity		-20 to 60°C, 75% max. (with no condensation)					
Operating and Storage Atmosphere		No corrosive gases or exposure to water-soluble cutting oil*					
Power Supply		100-240 VAC, 50-60 Hz	22-60 VDC	22-60 VDC	100-240 VAC, 50-60 Hz	22-60 VDC	22-60 VDC
Robot Arm Cable Length		3m/12m	1.5m	1.5m	3m/12m	1.5m	1.5m
I/O Ports	Control Box	Digital In: 16 Digital Out: 16 Analog In: 2 Analog Out: 1					
	Tool	Digital In: 4 Digital Out: 4 Analog In: 1 Analog Out: 0					
I/O Interface		3 X COM, 1 X HDMI, 3 X LAN, 4 X USB2.0, 2 X USB3.0					
Communication		RS232, Ethernet(master), Modbus TCP/RTU (master & slave), Optional Fieldbus (EtherNet/IP or PROFINET)					
Integrated Camera		5M pixels, color	5M pixels, color	5M pixels, color	5M pixels, color	5M pixels, color	5M pixels, color
I/O Power Supply		24V 1.5A (control box and tool)					
Programming Environment		TMflow, flowchart based					
SEMI S2 Certified*		No	No	Yes	No	No	Yes

\* SEMI safety guidelines are issued by an industry association with the same name: SEMI (Semiconductor Equipment and Materials International), which is the central global network of manufacturers of micro- and nano-electronics industries. SEMI S2 is the most well-known standard in semiconductor manufacturing equipment for EHS.

\* If water-soluble cutting oil is present, use a protective sleeve to prevent damage to the robot housing. OMRON offers enhanced joint covers for these applications. Contact your OMRON representative for more information.

# Collaborative Robots

# TM16

## Collaborative robot for assembly, packaging, inspection and logistics

- Designed to promote a safe and harmonious workplace between humans and machines.
- Easy-to-use graphical programming environment for quick startup and operation.
- Built-in vision-based robot control enables visual serving, inspection, and measurement operations.
- TMvision and landmark allows truly flexible, fast changeover.
- Plug & Play ecosystem provides the tools and versatility for many manufacturing needs.
- Capability to integrate with mobile robots enables fully autonomous machine tending and logistics handling applications.



TM16

## Specifications

		TM16			
Product Name		TM16	TM16M	TM16M SEMI	TM16X
Weight (kg)		32.2			31.9
Controller Weight (kg)		14.1			
Max Payload (kg)		16			
Reach (mm)		900			
Mounting		Wall, Table, Ceiling			
Typical Speed (m/s)		1.1			
Joint Range	Joint 1	±270°			±360°
	Joint 2, 4, 5	±180°			±360°
	Joint 3	±166°			±163°
	Joint 6	±270°			±360°
Joint Speeds	Joint 1, 2	±120°			
	Joint 3, 4, 5, 6	±180°			
Repeatability (mm)		±0.1			
IP		IP54 (robot arm), IP32 (control box), IP40 (robot stick)			
Cleanroom Class		ISO Class 5			
Operating Temperature and Humidity		0 to 50°C, 85% max. (with no condensation)			
Storage Temperature and Humidity		-20 to 60°C, 75% max. (with no condensation)			
Operating and Storage Atmosphere		No corrosive gases or exposure to water-soluble cutting oil*			
Power Supply		100-240 VAC, 50-60 Hz	22-60 VDC	22-60 VDC	100-240 VAC, 50-60 Hz
Robot Arm Cable Length		3m/12m	1.5m	1.5m	3m/12m
I/O Ports	Control Box	Digital In: 16 Digital Out: 16 Analog In: 2 Analog Out: 1			
	Tool	Digital In: 4 Digital Out: 4 Analog In: 1 Analog Out: 0			
I/O Interface		3 X COM, 1 X HDMI, 3 X LAN, 4 X USB2.0, 2 X USB3.0			
Communication		RS232, Ethernet(master), Modbus TCP/RTU (master & slave), Optional Fieldbus (EtherNet/IP or PROFINET)			
Integrated Camera		5M pixels, color			
I/O Power Supply		24V 1.5A (control box and tool)			
Programming Environment		TMflow, flowchart based			
SEMI S2 Certified*		No	No	Yes	No

\* SEMI safety guidelines are issued by an industry association with the same name: SEMI (Semiconductor Equipment and Materials International), which is the central global network of manufacturers of micro- and nano-electronics industries. SEMI S2 is the most well-known standard in semiconductor manufacturing equipment for EHS.

\* If water-soluble cutting oil is present, use a protective sleeve to prevent damage to the robot housing. OMRON offers enhanced joint covers for these applications. Contact your OMRON representative for more information.

# Ordering Information

## Model Number Legend

**RT6** - □ □ □ □ □ □ □ □  
 (1) (2) (3) (4) (5) (6) (7) (8)

No.	Item	Specifications	Symbol
(1)	Collaborative Robots - Omron Techman		
(2)	Model Type	TM5	0
		TM12	1
		TM14	2
		TM 16	8
(3)	Power Supply	AC	0
		DC	1
(4)	Vision System	Integrated Camera	0
		No Camera (X Model)	1
(5)(6)	Arm Length	700 (TM5)	70
		900 (TM5 and TM16)	90
		1300 (TM12)	13
		1100 (TM14)	11
(7)	Other Options	Standard	0
		SEMI S2 Certified	1
		Fieldbus (Ethernet/IP or PROFINET)	2
(8)	Cable Length	Standard Length (3m/1.5m) *2	1
		Extended Length (12m) *3	2















\*1. X model refers to robot models without integrated camera system.  
 \*2. 1.5m cable is only standard on DC models. 12m cable is not available on DC models.









## Robot Parts Code and Bundled Accessories

Type	TM5-700					TM5-900				
Product Name	TM5-700	TM5M-700	TM5M-700 SEMI	TM5X-700	TM5MX-700	TM5-900	TM5M-900	TM5M-900 SEMI	TM5X-900	TM5MX-900
<b>Overview</b>	Robot and control box with built-in vision system				Robot and control box without vision system	Robot and control box with built-in vision system				Robot and control box without vision system
<b>Purpose</b>	Typical for use in single collaborative robot system					Typical for use in single collaborative robot system				
<b>Bundled Accessories</b>	<ul style="list-style-type: none"> <li>• TM5-700 robot arm (1), standard cable length 300 cm, optional 600 cm and 1200 cm</li> <li>• Robot stick (1), 300 cm</li> <li>• Control box (1)</li> <li>• Calibration plates (one large and one small) (not included with the X model bundles)</li> <li>• IO cables,(2 ) 100 cm</li> <li>• Landmark (2) (not included with the X model bundles)</li> <li>• Ground wire (2), 300 cm</li> <li>• Jumper wire (2), 3 cm</li> <li>• Power cable for the control box,(4 cable, Type B, I, G, F), 180 cm, (4 standard part number, 1 mobile part number)</li> <li>• SEMI emergency OFF switch (SEMI model only)</li> <li>• SEMI Estop cable (1), 300 cm</li> </ul>					<ul style="list-style-type: none"> <li>• TM5-900 robot arm (1), standard cable length 300 cm, optional 600 cm and 1200 cm</li> <li>• Robot stick (1), 300 cm</li> <li>• Control box (1)</li> <li>• Calibration plates (one large and one small) (not included with the X model bundles)</li> <li>• IO cables,(2 ) 100 cm</li> <li>• Landmark (2) (not included with the X model bundles)</li> <li>• Ground wire (2), 300 cm</li> <li>• Jumper wire (2), 3 cm</li> <li>• Power cable for the control box,(4 cable, Type B, I, G, F), 180 cm, (4 standard part number, 1 mobile part number)</li> <li>• SEMI emergency OFF switch (SEMI model only)</li> <li>• SEMI Estop cable (1), 300 cm</li> </ul>				
Type	TM12					TM14				
Product Name	TM12	TM12M	TM12M SEMI	TM12X	TM12MX	TM14	TM14M	TM14M SEMI	TM14X	TM14MX
<b>Overview</b>	Robot and control box with built-in vision system				Robot and control box without vision system	Robot and control box with built-in vision system				Robot and control box without vision system
<b>Purpose</b>	Typical for use in single collaborative robot system					Typical for use in single collaborative robot system				
<b>Bundled Accessories</b>	<ul style="list-style-type: none"> <li>• TM12 robot arm (1), standard cable length 300 cm, optional 600 cm and 1200 cm</li> <li>• Robot stick (1), 300 cm</li> <li>• Control box (1)</li> <li>• Calibration plates (one large and one small) (not included with the X model bundles)</li> <li>• IO cables,(2 ) 100 cm</li> <li>• Landmark (2) (not included with the X model bundles)</li> <li>• Ground wire (2), 300 cm</li> <li>• Jumper wire (2), 3 cm</li> <li>• Power cable for the control box,(4 cable, Type B, I, G, F), 180 cm, (4 standard part number, 1 mobile part number)</li> <li>• SEMI emergency OFF switch (SEMI model only)</li> <li>• SEMI Estop cable (1), 300 cm</li> </ul>					<ul style="list-style-type: none"> <li>• TM14 robot arm (1), standard cable length 300 cm, optional 600 cm and 1200 cm</li> <li>• Robot stick (1), 300 cm</li> <li>• Control box (1)</li> <li>• Calibration plates (one large and one small) (not included with the X model bundles)</li> <li>• IO cables,(2 ) 100 cm</li> <li>• Landmark (2) (not included with the X model bundles)</li> <li>• Ground wire (2), 300 cm</li> <li>• Jumper wire (2), 3 cm</li> <li>• Power cable for the control box,(4 cable, Type B, I, G, F), 180 cm, (4 standard part number, 1 mobile part number)</li> <li>• SEMI emergency OFF switch (SEMI model only)</li> <li>• SEMI Estop cable (1), 300 cm</li> </ul>				

# Accessories & Software

## Accessories









Appearance	Product Name	Description	Remarks	Part Number
	Landmark	Robot positioning tool as a reference to the environment.	2 included with purchase of a robot. Compatible with all hardware versions.	RT6-A000021
	Landmark	Robot positioning tool as a reference to the environment.	Legacy version with TM logo. Compatible with all hardware versions.	RT6-A000008
	Mobile Workstation (MWS)	MWS is a convenient tool for users to mount the robot arm on work surface, and store the control box safely within. Users can move the MWS with the robot to different work cells easily.	Compatible with OMRON TM5 only.	RT6-A000010
	Robot stand	Similar to MWS, the robot stand can be moved with the robot to different work stations easily.	Height adjustable. Compatible with OMRON TM5 only.	RT6-A000009
	SSD with cable	128 GB solid state hard drive.	SATA cable included. Recommended for external cameras image logging.	RT6-A000012
	Kit, calibration set with additional pin	Toolkit for teaching a precise tool center point (TCP) that can be used for manual workspace calibration within TMvision	Required for TCP and manual vision calibration	RT6-A000002
	Robot stick stand	Mounting fixture for the robot stick.	Can be used on desktops, walls, and MWS.	RT6-A000000
	Pneumatic control box	Controls the inputs and outputs and monitors air pressure for Kilews screw driving applications.	Compatible with Kilews screw driving solution kit only. Recommended to attach to the robot stand.	RT6-A000015
	Air Filter (ROHS)	Replacement air filter for the control box.	The filter must be changed regularly to maintain efficiency. The replacement procedure can be found in the Hardware Installation Manual.	19936-443F
	Fieldbus Communication Adapter	Fieldbus retrofit kit for Omron TM cobots. Adds EtherNet/IP and Profinet communication capabilities.	Installation must be performed by Omron personnel.	19936-820F
	Robotiq Adaptive Gripper 2-Finger 85/140 for OMRON TM robot	A 2-finger adaptive gripper that can adapt to parts of various shapes and sizes. Comes in two stroke options – 85mm and 140mm.	Each kit includes: - End effector coupling kit - 10-meter communication cable - RS485 to RS232 converter - RS485 to USB converter - Screw kit - Quick start guide	85 kit: AGC-OMRON-KIT-85 140 kit: AGC-OMRON-KIT-140
	Robotiq Hand-E gripper for OMRON TM robot	A 2-finger parallel gripper with an IP67 rating. 50mm stroke.	Each kit includes: - Fingertip starting kit - End effector coupling kit - 10-meter communication cable - RS485 to RS232 converter - RS485 to USB converter - Screw kit - Quick start guide	HND-OMRON-KIT
	Robotiq EPick for Omron TM robot	A vacuum gripper that uses an integrated vacuum generator.	1 vacuum cup	VAC-OMRON-EPICK-KIT1
		Each kit includes: -Basic gripper unit -End effector coupling kit -10-meter communicable cable -RS485 to RS232 converter -RS485 to USB converter -Quick start guide -Vacuum cup(s): 1.5 bellows, 55mm diameter	A suction system for 2 cups	VAC-OMRON-EPICK-KIT2
			A suction system for 4 cups	VAC-OMRON-EPICK-KIT4











Appearance	Product Name	Description	Remarks	Part Number
	Robotiq AirPick for Omron TM robot	A vacuum gripper that uses an external pneumatic supply.  Each kit includes: -Basic gripper unit -Tubing 8mm-8m -End effector coupling kit -RS485 to RS232 converter -RS485 to USB converter -Quick start guide -Vacuum cup(s): 1.5 bellows, 55mm diameter	1 vacuum cup	VAC-OMRON-AIRPICK-KIT1
			A suction system for 2 cups	VAC-OMRON-AIRPICK-KIT2
			A suction system for 4 cups	VA-OMRON-AIRPICK-KIT4
	Robotiq I/O Coupling	Component that connects the Robotiq adaptive/vacuum gripper to the wrist of the OMRON TM robot to eliminate the need for an external serial communication cable.	Each kit includes: - I/O Coupling - Screw kit - Micro-USB to USB cable	IO-CPL-OMRON-KIT
	Robotiq Dual-Grip Adapter Plate	Adapter plate and mounting screws to mount two grippers onto the OMRON TM robot.		AGC-APL-159-002
	Robotiq 2F-85 Dual kit for OMRON Robots	Kit that enables dual gripper setting.	Each kit includes: - Chosen gripper x 2 - Mechanical coupling x 2 - USB to RS485 Adapter - Communication Cable - M12 5 Pins Splitter - Dual-Grip Adapter Plate - Screw kit x 2	OMRON-DUAL-AGC-85
	Robotiq 2F-140 Dual kit for OMRON Robots			OMRON-DUAL-AGC-140
	Robotiq HAND-E Dual kit for OMRON Robots			OMRON-DUAL-HND
	Robotiq Force sensor FTS-300	Six-axis force/torque sensor with RS485 Serial Communication.	Each kit includes: - Coupling - RS485 to RS232 converter - Power and communication cable	FTS-300-OMRON-KIT
	Basler GigE Camera	External camera for eye-to-hand robot applications. Maximum 2 external cameras per robot.	Monochrome, 640 x 480, 120 fps, CCD (1/4-inch equivalent) 24114-100	
			Monochrome, 1600 x 1200, 60 fps, CMOS (1/1.8-inch equivalent) 24114-250	
			Monochrome, 2048 x 2048, 25 fps, CMOS (1-inch equivalent)	24114-300
	NexCobot	A handheld operating teach pendant and well-integrated with OMRON TM Robot. Features an ergonomic housing with safety	TP Package-Plug&Play for OM	RT6-A000020

## Software









Product Name	Add-On Product Names	Part Number	Add-On Part Numbers	Remarks
USB Dongle	-	RT6-A000004	-	Required for all extra software licenses.
TMflow	-	N/A, Free Download	-	Software required to control the cobot.
	TM Identify & Measure	-	RT6-S100000	License, add-on to TMflow. Includes: identification of pose variation, specific color area size, subtract reference image, line/circle burr, counting and gauge.
	TM External Vision	-	RT6-S100002	License, add-on to TMflow. Required when using eye-to-hand cameras.
	TM OCR	-	RT6-S100003	License, add-on to TMflow. Includes: Text OCR and Number OCR.
TMflow Editor	-	RT6-S200001	-	License, provides a convenient way to open and edit project offline.
	TMflow Editor - Offline AOI	-	RT6-S100005	License, add-on to TMflow Editor. Enables TMflow Editor to offline edit a TMflow project that includes AOI vision.

## Recommended Plug & Play Hardware







Category	Appearance	Company	Product Name	Manufacturer SKU Number*	Description
Grippers		OnRobot	RG2-FT	102075	The RG2-FT has 2 force/torque sensors and 2 time-of-flight based proximity sensors integrated in the fingertips. It's a state of the art gripper with added sensing and intelligence, capable of controlling the robot and itself to achieve what the operator would like it to do, even when the exact parameters cannot be programmed in advance. It includes: <ul style="list-style-type: none"> <li>- RG2-FT Gripper</li> <li>- Fingertip adapter (pre-mounted)</li> <li>- Cable</li> <li>- Cable holder and screws</li> </ul> Required option for mounting on the robot: <ul style="list-style-type: none"> <li>- single quick changer (robot side)</li> <li>- dual quick changer (robot side)</li> <li>- HEX QC</li> </ul> Required option for connecting to the robot: <ul style="list-style-type: none"> <li>- connection kit with compute box</li> </ul>
			RG6 Gripper	102021	Electric 2-finger gripper with larger stroke. Each kit includes: <ul style="list-style-type: none"> <li>- RG2 Gripper</li> <li>- Fingertip adapters (pre-mounted)</li> <li>- Integrated Quick Changer (tool side)</li> <li>- Torx key</li> </ul>
			VG10 Electric Vacuum Gripper	101661	Flexible and adjustable electrical vacuum gripper. Each kit includes: <ul style="list-style-type: none"> <li>- VG10 Gripper</li> <li>- d30mm suction cups x 16 (pre-mounted)</li> <li>- Integrated Quick Changer (tool side)</li> <li>- d40mm suction cups x4</li> <li>- d15mm suction cups x4</li> <li>- Blind screws x16</li> <li>- Positioning arrows</li> <li>- Torx key</li> </ul>
			Single Pad Gecko	104086 SP1 104087 SP3 104088 SP5	Compact, lightweight Gecko Single Pad Gripper requires no cables, electricity, air or programming. The Gecko SP is available in 3 sizes; SP1, SP3, and SP5 named after the grippers payload in kilos, featuring the ability to lift a wide range of flat, smooth, shiny or perforated surfaces. Options are: Gecko SP1 (with 35mm pad) Gecko SP3 (with 60mm pad) Gecko SP5 (with 75mm pad)
			OMRON TM Robot Kit	102359	This kit must be purchased for the use of OnRobot grippers on OMRON TM collaborative robot. Each kit includes: <ul style="list-style-type: none"> <li>- Compute Box</li> <li>- Power supply</li> <li>- Adapter plate (included in all kits but only necessary for VG10 and Gecko grippers)</li> <li>- USB stick with software components and User Manual</li> <li>- Device cable 5m</li> <li>- UTP cable 0.5m</li> <li>- I/O cable 0.3m</li> <li>- Cable management hook/loop</li> </ul>
			3FG15-3 Finger Gripper	103666	The 3FG15 is ideal for gripping a wide range of cylindrical objects in machine-tending applications such as CNC lathe machines. The grippers design automatically centers workpieces, with payload up to 15kg. It includes: <ul style="list-style-type: none"> <li>- 3FG15</li> <li>- Torx Key T20</li> <li>- 3 x Steel Fingertip Ø13</li> <li>- 3 x Rubber Fingertip Ø 16,5</li> </ul>
			Soft Gripper	103546 SG Base Part 103689 SG-a-H 103860 SG-a-S 103691 SG-b-H	This is available with three interchangeable silicon-molded cups to handle a wide array of irregular shapes and delicate items, making it ideal for pick-and-place applications in food and beverage and other "clean" production applications. The silicon cups are dishwasher-safe and comply with FDA 21 CFR (for non-fatty items) and EC 1935/2004 for food handling. Maximum payload of 2.2 kg, and grip dimensions range from 11mm to 118mm, depending on cup used.
			VGC10	102844	This flexible electric vacuum gripper has changeable suction cup options for unlimited customization possibilities. It's smaller and at half the weight of VG10 but with the same payload. It includes: <ul style="list-style-type: none"> <li>- D40mm Vacuum Cups</li> <li>- D30mm Vacuum Cups</li> <li>- D15mm Vacuum Cups</li> <li>- Fittings</li> <li>- Push-in fittings</li> <li>- M6x10mm Screws</li> <li>- Blind Screws</li> <li>- Torx T30</li> <li>- Allen 3mm Keys</li> <li>- Adapter Plate</li> <li>- Extension pipe 50mm</li> </ul>



Category	Appearance	Company	Product Name	Manufacturer SKU Number*	Description
Grippers		Schmalz	ROB-SET ECBPI OMRON	10.03.01.00544	Complete vacuum gripper for collaborative robots. Each kit includes: - Vacuum generator (ECBPI) - End-effector coupling kit - Connection cable - Mounting flange - Flat suction cup - Bellows suction cup - Bolts and t-nuts - Operating instructions
			ROB-SET FXCB OMRON	10.01.43.00120	Area gripper equipped with integrated pneumatic vacuum generation. (Needs external air supply.) Each kit includes: - Pneumatic area gripper (FXCB) - Connection cable - Mounting flange - Bolts and t-nuts - Operating instructions
		Schunk	Co-act EGP-C 40 N-N-TMID	1374363	Electric 2-finger parallel gripper certified for collaborative operation with actuation via 24 V and digital I/O. Each kit includes: - Co-act EGP-C gripper - Assembly and Operating Manual - Accessory pack
			Co-act AUB EGP 40/12	1401285	Gripping fingers for Co-act EGP-C.
			Co-act AUB EGP 40/24	1401286	
		Co-act AUB-F EGP 40/xx	1409839		
		SMC	Air Gripper	JMHZ2X7400BTM	Air gripper equipped with a high precision linear guide. Compact, lightweight product with high gripping force due to air operation. Operate by simply connecting one air supply tube and an electrical wiring M8 connector. Each kit includes: - Air gripper unit - Parallel pin (6x10mm) x 1 - Hexagon socket head cap screw (M6x23) x 4 - Protective cover x1 set (valve side, S.W side) - Hexagon socket head cap screw (M4x10) x 4 - Tube for piping (TU0425BU) 2m - User manual
			Vacuum Gripper	ZXP-X1	Operate by simply connecting one compressed air supply tube and an electrical wiring M8 connector. The wide variety of SMC suction cup variations can apply to a wide range of picking applications. The adsorbing detection is made easy with sensor signals. Each kit includes: - Vacuum gripper unit - Robot mounting flange - 6x10, parallel pin - 8 pcs x M6 x 10, Hexagon socket head cap screw - 2m, Polyurethane tube: TU0604 - Plug 4 pcs (cup mounting flange) - 4 pcs x suction cup with adapter (suction cup)
		CKD	Compact Gripper RLSH-TM	RLSH-A20D1NL1-FY2-TM	Small, lightweight, pneumatic gripper with high gripping force. Easy installation with a dedicated common flange and tool-less replacement with a clamp ring, and teaching support is supported with the dedicated software "Pneumatic Gripper." Equipped with an edgeless resin cover and an LED indicator lamp that is visible 360 degrees, it is designed with consideration for safety and supports the introduction of collaborative robots by all customers.
	Long Stroke Gripper RHLF-TM		RHLF-16CSFY2-TM		
	3-way Finger Gripper RCKL-TM		RCKL-16CSFY3-TM		



Category	Appearance	Company	Product Name	Manufacturer SKU Number*	Description
Tool Changers		KOSMEK	Robotic Tool Changer	Master Cylinder: SWR0070-M□-□ SWR0120-M□-□ Conversion Plate Set: SWRZ0070-MF4 SWRZ0120-MF4 Tool Adapter: SWR0070-T-□ SWR0120-T-□	High-precision robotic tool changer with many features enables multiple functions of robots and setup time reduction. It enhances the productivity of the automated production line.
		OnRobot	Quick Changer-robot side	102037	Manual tool changer to attach on the robot's end-of-arm. Either the Quick Changer (robot side) or the Dual Quick Changer must be purchased for use of all OnRobot grippers. Each kit includes: - Quick Changer robot side - Screws - Torx key
			Quick Changer- tool side	102014	Manual tool changer to attach on the tool side. (All OnRobot grippers have this component integrated, so this is only necessary when user is developing own tool.)
			Quick Changer Kit	102277	Each kit includes: - Quick Changer (robot side)x1 - Quick Changer (tool side)x2 - Torx key - Screws and pins
			Dual Quick Changer	101788	Manual tool changer to attach on the robot's end-of-arm for dual gripper configuration. Either the Quick Changer (robot side) or the Dual Quick Changer must be purchased for use of all OnRobot grippers. Each kit includes: - Dual Quick Changer - Screws - Torx key
3D Bin Picking		Pick-it	Pick-it M	PI-M-2.0	Plug & Play 3D camera and software for picking objects sized 50x50x10mm or larger. Each kit includes: - Pre-calibrated 3D camera - Pick-it software - Industrial processor - 3G dongle to connect directly to Pick-it support - Calibration plate and ROi box teaching markers - All connection cables (plug & play) - Quick start guide
			Pick-it M-HD	PI-M-HD	Plug & Play 3D camera and software for picking objects sized 10x10x5mm or larger. Each kit includes: - Pre-calibrated 3D camera - Pick-it software - Industrial processor - 3G dongle to connect directly to Pick-it support - Calibration plate and ROi box teaching markers - All connection cables (plug & play) - Quick start guide
Screw Driving		Kilews	Screw Driving Solution Kit	TM-BN512LAD-□.□	Kilews screwdriver kit. Pneumatic control box (RT6-A000015) is required and sold separately. Each kit includes: -Screwdriver SKD-BN512LM -Power control Box SKP-32BC-60W -Flange E31700-3 -Air Nozzle KS-TM-B500-□0 -Singal Box KL-SCBSN
OnRobot Screwdriving Tool		OnRobot	Screwdriver	103961 105121 104363 104374 105870	Smart screwdriver with screw feeder easily automates multiple screw driving processes with no downtime for manual changeovers. Precise torque control and intelligent error detection ensure quality and consistency. The following accessories are required depending on the screw size. -Screwdriver Accessory Kit Metric: Screwdriver bit system for various screw types and sizes -Screw Feeder M1-6: Automatic feeder for M1 to 6 size screws -Screw Feeder M2-6: Automatic feeder for M2 to 6 size screws -Angle Bracket

\* Manufacturer SKU numbers are 3rd party part numbers, not OMRON part numbers.

Category	Appearance	Company	Product Name	Manufacturer SKU Number*	Description
Vision		Basler	GigE camera, color, 5MP, CMOS 1/2.5", 14 fps	acA2500-14gc, Rolling Shutter	External camera for eye-to-hand robot applications. Maximum 2 external cameras per robot.
			GigE camera, mono, 5MP, CMOS 1/2.5", 14 fps	acA2500-14gm, Rolling Shutter	
			GigE camera, color, 5MP, CMOS 1", 21fps	acA2500-20gc, Global Shutter	
			GigE camera, mono, 5MP, CMOS 1", 21 fps	acA2500-20gm, Global Shutter	
			GigE camera, color, 5MP, CMOS 2/3", 23fps	acA2440-20gc, Global Shutter	
			GigE camera, mono, 5MP, CMOS 2/3", 23 fps	acA2440-20gm, Global Shutter	
			GigE, camera, color, 10MP, CMOS 1/2.3", 10 fps	acA3800-10gc, Rolling Shutter	
			GigE, camera, mono, 10MP, CMOS 1/2.3", 10 fps	acA3800-10gm, Rolling Shutter	
			GigE, camera, color, 12.2 MP, CMOS 1/1.7", 8 fps	acA4024-8gc, Rolling Shutter	
			GigE, camera, mono, 12.2 MP, CMOS 1/1.7", 8 fps	acA4024-8gm, Rolling Shutter	
Force sensor		ATI	Axia80	9105-TM-Axia80	Six-axis force/torque sensor with EtherCAT communication. Each kit includes: - Interface plate - Power and Ethernet cable - Digital delivery of calibration documents and user manual
		OnRobot	HEX-E/H	- 100551 HEX-H w/ EtherCAT Converter & Flange A - 100535 HEX-E w/ EtherCAT Converter & Flange A	HEX six-axis force torque sensors use a unique, optical principle to detect the smallest forces acting on the tool, with EtherCAT communication. The OnRobot force control software package is optimized for these sensors. It includes: - HEX-E or HEX H - Mounting plate - Screws - Cable - Torx key Required to connect the sensor to the robots: - Connection kit with Compute Box
7th Axis		Ewellix	LIFTKIT	LIFTKIT-OM-601	A ready-to-install system that includes a telescopic column with a mounting interface and controller. Stroke options (mm): 500, 600, 700, 800, 900. Each kit includes: - Telescopic pillar - Controller - TM attachment plate - Bottom fixation plate - Handswitch - Cables and screws
Connectivity		ADLINK	EtherCAT I/O Expansion Modules KIT	EPS - 9905+6000+2032+1132	A Kit that includes: chassis w/ EtherCAT ports and voltage input, 32-channel digital output module, 32-channel digital input module.
			EtherCAT I/O Expansion Modules (DO Module)	EPS-2032	32-channel digital output module.
			EtherCAT I/O Expansion Modules (DI Module)	EPS-1132	32-channel digital input module.
		Advantech	Serial Device Server EKI-1524-CE	EKI-1524-CE	External device with serial ports that communicates with the robot via TCP/IP.
Modbus to PROFINET Gateways			EKI-1242IPNMS	A gateway to transform Omron TM cobot's Modbus to PROFINET, whereby Omron TM cobot as slave could communicate with PROFINET master devices.	

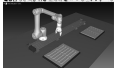
Category	Appearance	Company	Product Name	Manufacturer SKU Number*	Description
Cable Management		Murrplastik	FHS-C-SET TM5 (TM5-700 & TM5-900)	83693500	Cable management dress pack. Each kit includes: Conduit (Cable routing hose, Length:2m, Interior diameter: ~21mm) 4x Attachment straps 2x End plugs Cable insertion tool Installation instructions
			FHS-C-SET TM12 / TM14 (TM12 & TM14)	83693501	Cable management dress pack. Each kit includes: Conduit (Cable routing hose, Length:2m, Interior diameter: ~21mm) 2x Conduit clamps Self-retracting hose guide (2x Ball joint fixing, Ball joint strain relief, Feedback system, System holder) Tool-end clamp End sleeve Cable puller Installation instructions
			FHS-RS-SET TM5 (TM5-700 & TM5-900)	83693506	Cable management dress pack. Each kit includes: Conduit (Cable routing hose, Length:2m, Interior diameter: ~21mm) 2x Conduit clamps Self-retracting hose guide (2x Ball joint fixing, Ball joint strain relief, Feedback system, System holder) Tool-end clamp End sleeve Cable puller Installation instructions
			FHS-RS-SET TM12 / TM14 (TM12 & TM14)	83693507	Cable management dress pack. Each kit includes: Conduit (Cable routing hose, Length:2m, Interior diameter: ~21mm) 2x Conduit clamps Self-retracting hose guide (2x Ball joint fixing, Ball joint strain relief, Feedback system, System holder) Tool-end clamp End sleeve Cable puller Installation instructions
Robot Covers		12OZ 1000-DENIER NYLON OMRON/TM COLLABORATIVE ROBOSUIT		<ul style="list-style-type: none"> <li>• Excellent general use material for basic protection from dust, dirt and large grit</li> <li>• Not suited for use in wet applications as the material is breathable</li> <li>• Very low level of abrasion resistance</li> <li>• Wide range of color choices available</li> </ul>	
		18OZ FIRE-RETARDANT VINYL OMRON/TM COLLABORATIVE ROBOSUIT		<ul style="list-style-type: none"> <li>• Excellent general use material for most water-soluble coolants and cutting fluids, fine mesh grits and powders, de-ionized water, and limited protection from pressurized water spray/mist</li> <li>• Very low level of chemical and abrasion resistance</li> <li>• Wide range of color choices available</li> </ul>	
		17OZ HYPALON® IMPREGNATED VINYL OMRON/TM COLLABORATIVE ROBOSUIT		<ul style="list-style-type: none"> <li>• Excellent material for use in high-abrasion environments as well as metal chips (de-burr/cutting)</li> <li>• Provides limited levels of protection from water spray/mist while offering good levels of chemical resistance</li> <li>• Limited range of color choices available</li> </ul>	
		ALUMINUM COATED KEVLAR® OMRON/TM COLLABORATIVE COLLABORATIVE ROBOSUIT		<ul style="list-style-type: none"> <li>• Excellent material for use in high and low heat environments, light sparks and for UV protection</li> <li>• Nominal insulating factor of R-0.7</li> <li>• Maximum radiant operating temperature of 1500F. Minimum operating temperature - 65F</li> <li>• Silver in color</li> </ul>	
		10-MIL LAMINATED TEFLON® OMRON/TM COLLABORATIVE ROBOSUIT		<ul style="list-style-type: none"> <li>• Excellent protection in (caustic) chemical environments</li> <li>• FDA approved option, however, that does not equate to the Robosuit® being FDA-approved</li> <li>• Maximum radiant operating temperature of 650F</li> <li>• Grey in color</li> </ul>	
		ISOTHERM® WELD SPLATTER OMRON/TM COLLABORATIVE ROBOSUIT		<ul style="list-style-type: none"> <li>• Excellent material for use in low-inertia weld splatter and heavy spark applications</li> <li>• Maximum sustain (radiant) operating temperature of 500F. Short-term exposure to 700F</li> <li>• Grey in color</li> </ul>	
Simulation Software		RoboDK	RoboDK Simulation Software	N/A, Download	RoboDK is a powerful and cost-effective simulator and programming tool. No programming skills are required to generate complex robot path. Custom 3D model can be imported to quickly simulate real life application.

\* Manufacturer SKU numbers are 3rd party part numbers, not OMRON part numbers.

# Dimensions

(Unit: mm)

## TM5-700

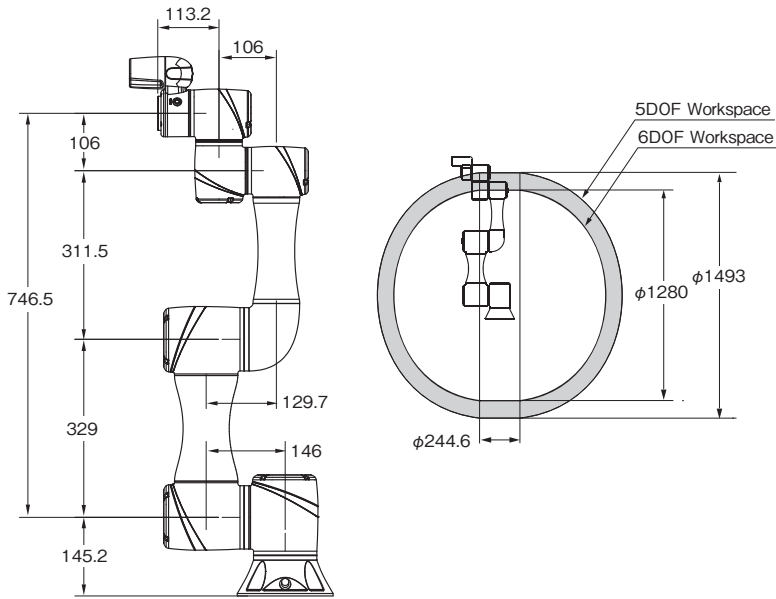

## Footprint

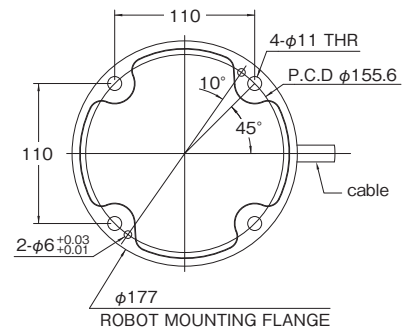

## Flange

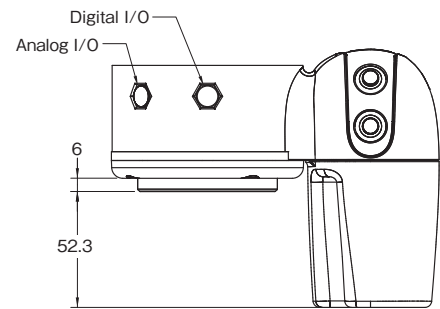

## TM5-900

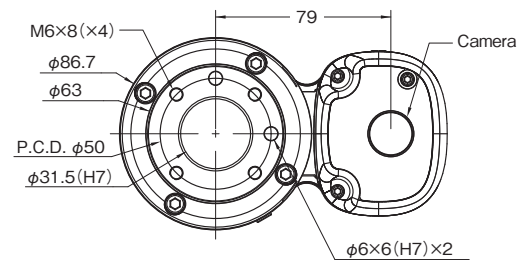
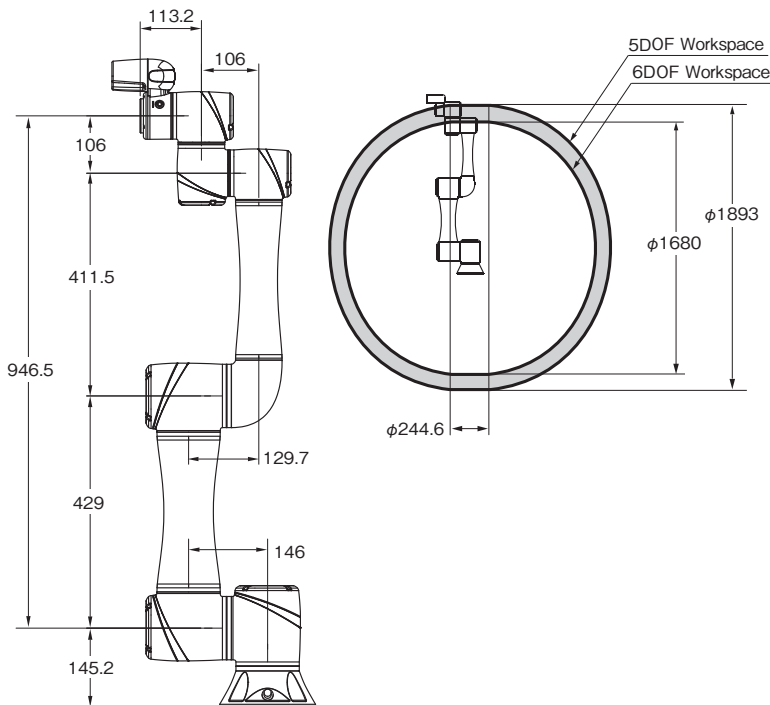

## Control Box

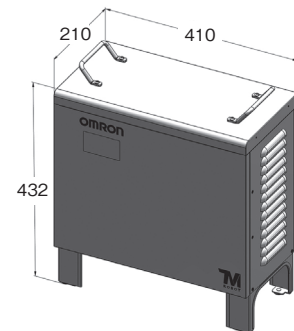

# Dimensions

(Unit: mm)

## TM12

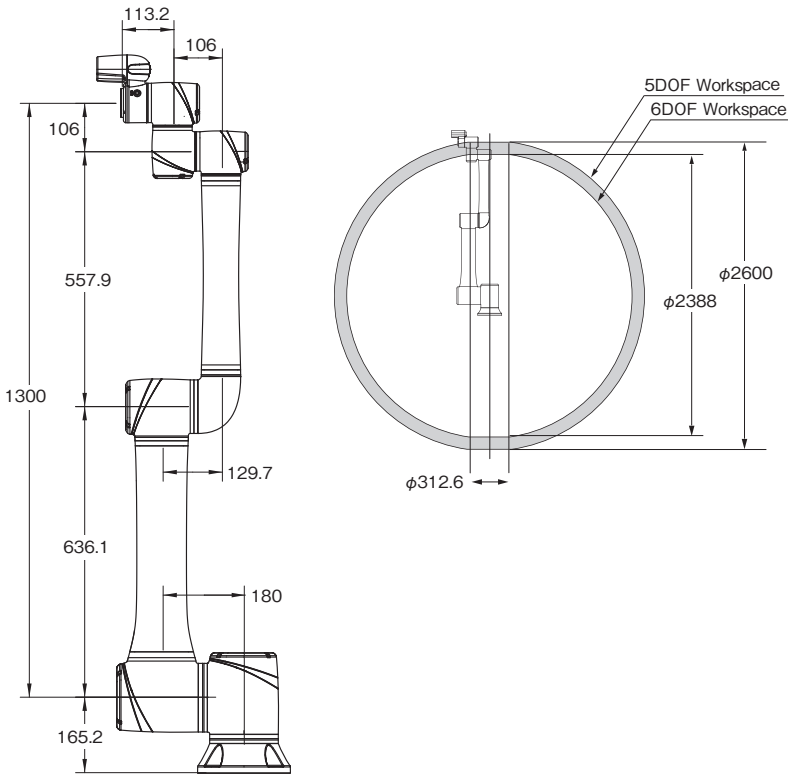

## Footprint

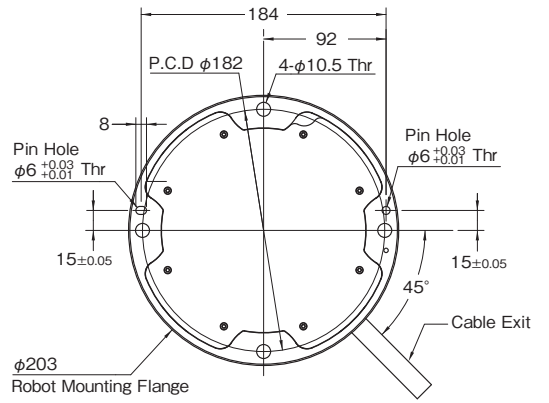

## Flange

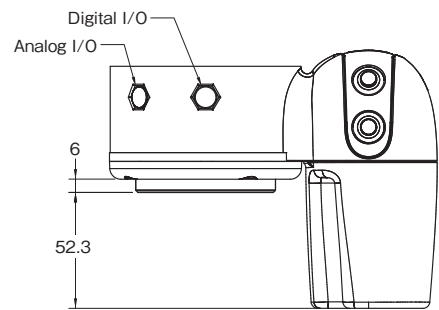

## TM14

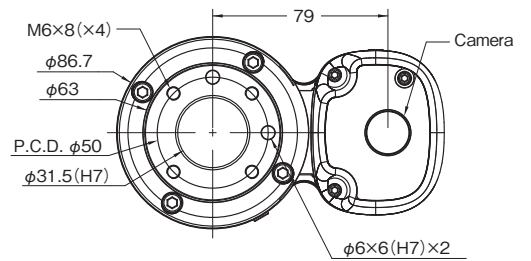
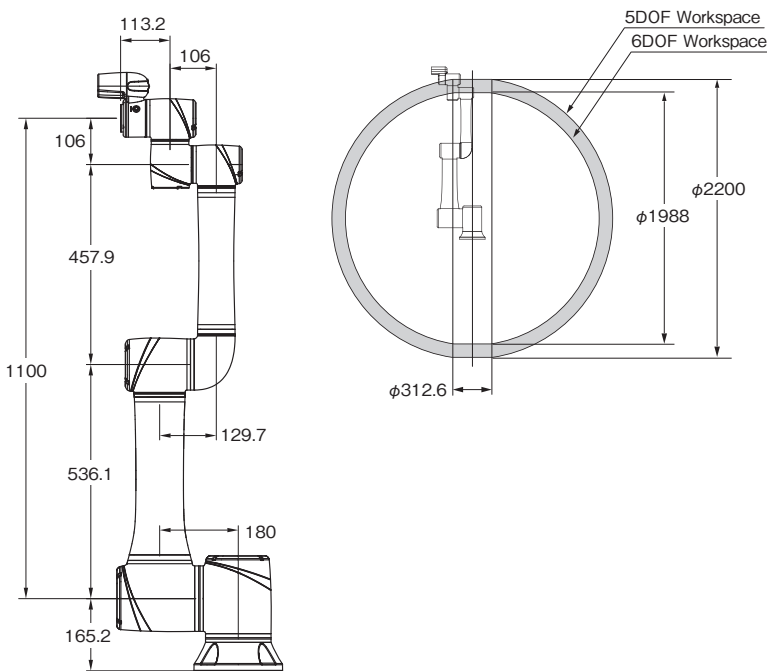

## Control Box

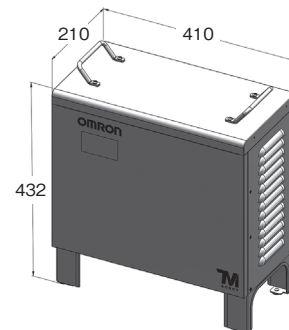

# Dimensions

(Unit: mm)

## TM16

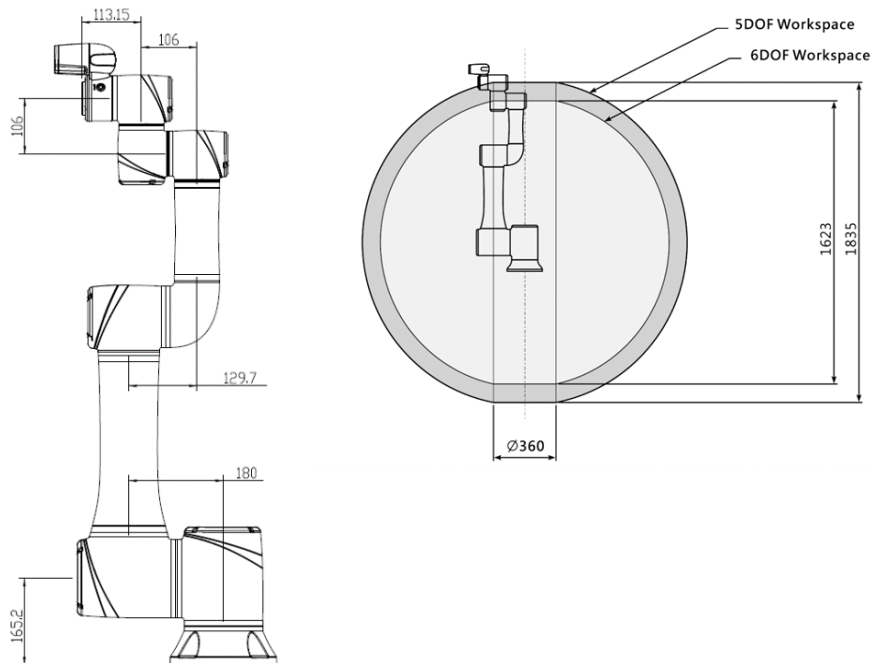

### Flange

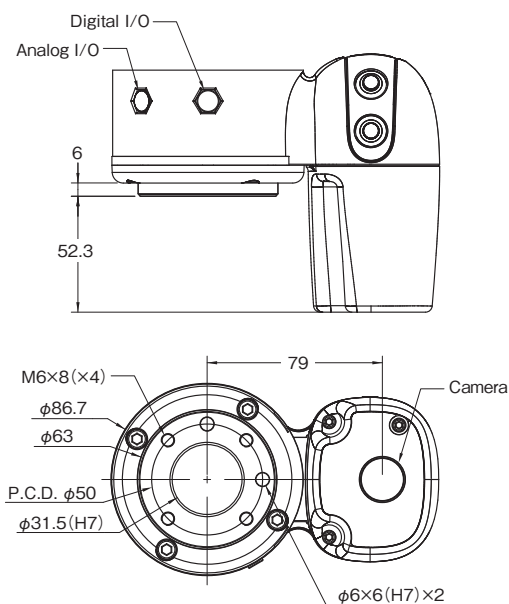

### Footprinting

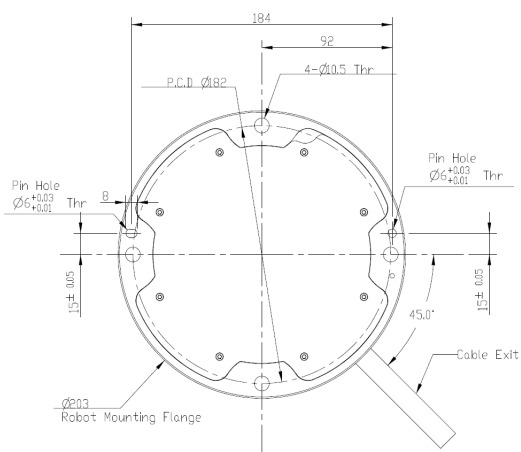

BOTTOM VIEW OF ROBOT BASE

### Control Box

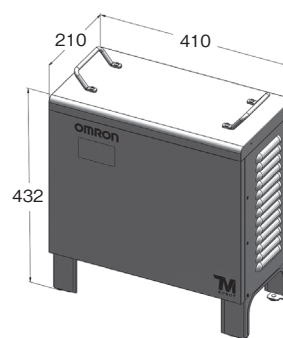

# Accessories Dimensions

(Unit: mm)

## Mobile Work Station (MWS)

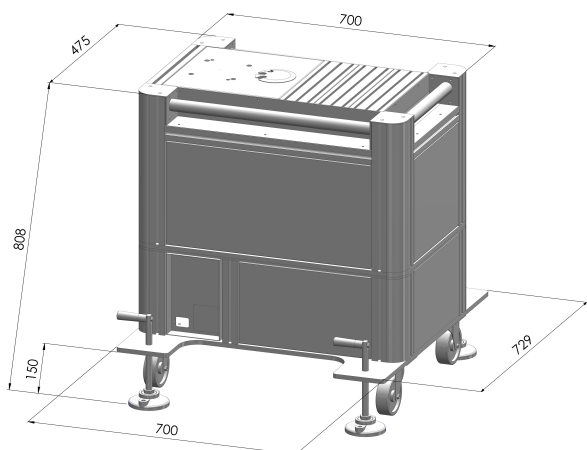

## Robot Stand

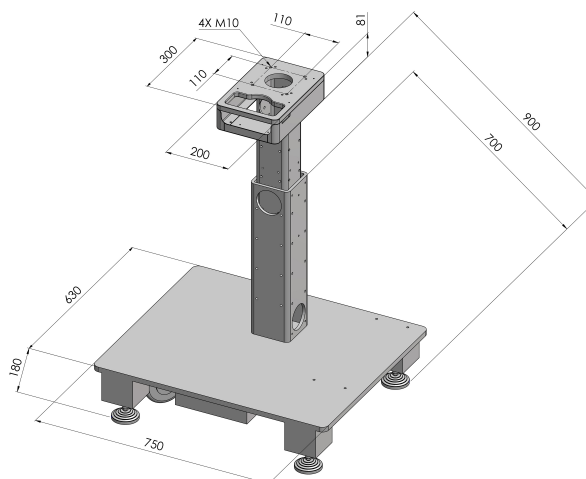

## Pneumatic Control Box

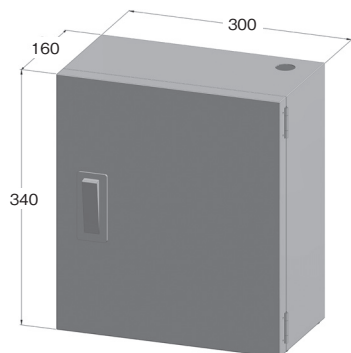

## Related Manuals

Manual No.	English Title
I623	TM5 Regular Payload Series Hardware Installation Manual
I624	TM12 & TM14 Medium & Heavy Payload Series Hardware Installation Manual
I626	Software Manual TMflow
I627	Software Manual TMvision
I628	TM Mobile Work Station Manual
I629	TM Robot Stand Manual
I630	Pneumatic Control Box Manual
I648	Safety Manual Safety System 3.2
I848	Expression Editor and Listen Node Reference Guide

**OMRON AUTOMATION AMERICAS HEADQUARTERS** • Chicago, IL USA • 847.843.7900 • 800.556.6766 • automation.omron.com

**OMRON CANADA, INC. • HEAD OFFICE**

Toronto, ON, Canada • 416.286.6465 • 866.986.6766 • automation.omron.com

**OMRON ELECTRONICS DE MEXICO • HEAD OFFICE**

Ciudad de México • 52.55.5901.4300 • 01.800.386.6766 • mela@omron.com

**OMRON ELECTRONICS DE MEXICO • SALES OFFICE**

San Pedro Garza García, N.L. • 81.12.53.7392 • 01.800.386.6766 • mela@omron.com

**OMRON ELECTRONICS DE MEXICO • SALES OFFICE**

Eugenio Garza Sada, León, Gto • 01.800.386.6766 • mela@omron.com

**OMRON ELETRÔNICA DO BRASIL LTDA • HEAD OFFICE**

São Paulo, SP, Brasil • 55 11 5171-8920 • automation.omron.com

**OMRON ARGENTINA • SALES OFFICE**

Buenos Aires, Argentina • +54.11.4521.8630 • +54.11.4523.8483  
mela@omron.com

**OTHER OMRON LATIN AMERICA SALES**

+54.11.4521.8630 • +54.11.4523.8483 • mela@omron.com

*Authorized Distributor:*

**Controllers & I/O**

- Machine Automation Controllers (MAC) • Motion Controllers
- Programmable Logic Controllers (PLC) • Temperature Controllers • Remote I/O

**Robotics**

- Industrial Robots • Mobile Robots

**Operator Interfaces**

- Human Machine Interface (HMI)

**Motion & Drives**

- Machine Automation Controllers (MAC) • Motion Controllers • Servo Systems
- Frequency Inverters

**Vision, Measurement & Identification**

- Vision Sensors & Systems • Measurement Sensors • Auto Identification Systems

**Sensing**

- Photoelectric Sensors • Fiber-Optic Sensors • Proximity Sensors
- Rotary Encoders • Ultrasonic Sensors

**Safety**

- Safety Light Curtains • Safety Laser Scanners • Programmable Safety Systems
- Safety Mats and Edges • Safety Door Switches • Emergency Stop Devices
- Safety Switches & Operator Controls • Safety Monitoring/Force-guided Relays

**Control Components**

- Power Supplies • Timers • Counters • Programmable Relays
- Digital Panel Meters • Monitoring Products

**Switches & Relays**

- Limit Switches • Pushbutton Switches • Electromechanical Relays
- Solid State Relays

**Software**

- Programming & Configuration • Runtime