

N-channel 600 V, 0.340 Ω typ., 11 A MDmesh™ M2 EP Power MOSFET in a TO-220 package

Datasheet - production data

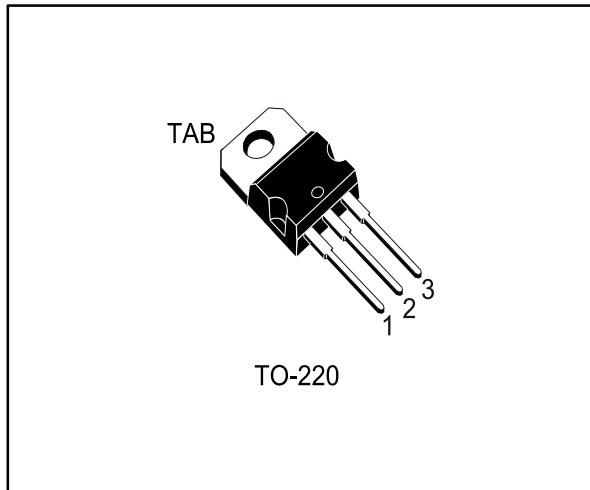
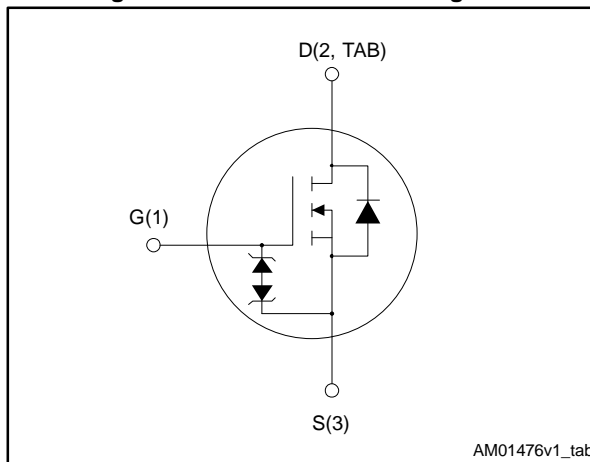

Figure 1: Internal schematic diagram



Features

| Order code | V_{DS} @ T_{Jmax} | $R_{DS(on)}$ max. | I_D |
|---------------|-----------------------|-------------------|-------|
| STP15N60M2-EP | 650 V | 0.378 Ω | 11 A |

- Extremely low gate charge
- Excellent output capacitance (C_{oss}) profile
- Very low turn-off switching losses
- 100% avalanche tested
- Zener-protected

Applications

- Switching applications
- Tailored for very high frequency converters ($f > 150$ kHz)

Description

This device is an N-channel Power MOSFET developed using MDmesh™ M2 EP enhanced performance technology. Thanks to its strip layout and an improved vertical structure, the device exhibits low on-resistance, optimized switching characteristics with very low turn-off switching losses, rendering it suitable for the most demanding very high frequency converters.

Table 1: Device summary

| Order code | Marking | Package | Packaging |
|---------------|-----------|---------|-----------|
| STP15N60M2-EP | 15N60M2EP | TO-220 | Tube |

Contents

| | | |
|----------|--|-----------|
| 1 | Electrical ratings | 3 |
| 2 | Electrical characteristics | 4 |
| | 2.1 Electrical characteristics (curves)..... | 6 |
| 3 | Test circuits | 8 |
| 4 | Package mechanical data | 10 |
| | 4.1 TO-220 type A package information..... | 11 |
| 5 | Revision history | 13 |

1 Electrical ratings

Table 2: Absolute maximum ratings

| Symbol | Parameter | Value | Unit |
|----------------|---|-------------|------|
| V_{GS} | Gate-source voltage | ± 25 | V |
| I_D | Drain current (continuous) at $T_C = 25\text{ °C}$ | 11 | A |
| I_D | Drain current (continuous) at $T_C = 100\text{ °C}$ | 7 | A |
| $I_{DM}^{(1)}$ | Drain current (pulsed) | 44 | A |
| P_{TOT} | Total dissipation at $T_C = 25\text{ °C}$ | 110 | W |
| $dv/dt^{(2)}$ | Peak diode recovery voltage slope | 15 | V/ns |
| $dv/dt^{(3)}$ | MOSFET dv/dt ruggedness | 50 | V/ns |
| T_{stg} | Storage temperature | - 55 to 150 | °C |
| T_j | Max. operating junction temperature | | |

Notes:

(1) Pulse width limited by safe operating area.

(2) $I_{SD} \leq 11\text{ A}$, $di/dt \leq 400\text{ A}/\mu\text{s}$; $V_{DS\text{ peak}} < V_{(BR)DSS}$, $V_{DD} = 400\text{ V}$.

(3) $V_{DS} \leq 480\text{ V}$

Table 3: Thermal data

| Symbol | Parameter | Value | Unit |
|----------------|---|-------|------|
| $R_{thj-case}$ | Thermal resistance junction-case max | 1.14 | °C/W |
| $R_{thj-amb}$ | Thermal resistance junction-ambient max | 62.5 | °C/W |

Table 4: Avalanche characteristics

| Symbol | Parameter | Value | Unit |
|----------|--|-------|------|
| I_{AR} | Avalanche current, repetetive or not repetetive (pulse width limited by T_{jmax}) | 2.8 | A |
| E_{AS} | Single pulse avalanche energy (starting $T_j = 25\text{ °C}$, $I_D = I_{AR}$; $V_{DD} = 50\text{ V}$) | 125 | mJ |

2 Electrical characteristics

$T_C = 25\text{ °C}$ unless otherwise specified

Table 5: On/off states

| Symbol | Parameter | Test conditions | Min. | Typ. | Max. | Unit |
|---------------|-----------------------------------|--|------|-------|----------|---------------|
| $V_{(BR)DSS}$ | Drain-source breakdown voltage | $V_{GS} = 0\text{ V}$, $I_D = 1\text{ mA}$ | 600 | | | V |
| I_{DSS} | Zero gate voltage Drain current | $V_{GS} = 0\text{ V}$, $V_{DS} = 600\text{ V}$ | | | 1 | μA |
| | | $V_{GS} = 0\text{ V}$, $V_{DS} = 600\text{ V}$, $T_C = 125\text{ °C}$ | | | 100 | μA |
| I_{GSS} | Gate-body leakage current | $V_{DS} = 0\text{ V}$, $V_{GS} = \pm 25\text{ V}$ | | | ± 10 | μA |
| $V_{GS(th)}$ | Gate threshold voltage | $V_{DS} = V_{GS}$, $I_D = 250\text{ }\mu\text{A}$ | 2 | 3 | 4 | V |
| $R_{DS(on)}$ | Static drain-source on-resistance | $V_{GS} = 10\text{ V}$, $I_D = 5.5\text{ A}$ | | 0.340 | 0.378 | Ω |

Table 6: Dynamic

| Symbol | Parameter | Test conditions | Min. | Typ. | Max. | Unit |
|----------------------------|-------------------------------|--|------|------|------|----------|
| C_{iss} | Input capacitance | $V_{DS} = 100\text{ V}$, $f = 1\text{ MHz}$, $V_{GS} = 0\text{ V}$ | - | 590 | - | pF |
| C_{oss} | Output capacitance | | - | 30 | - | pF |
| C_{rss} | Reverse transfer capacitance | | - | 1.1 | - | pF |
| $C_{oss\text{ eq.}}^{(1)}$ | Equivalent output capacitance | $V_{DS} = 0\text{ to }480\text{ V}$, $V_{GS} = 0\text{ V}$ | - | 148 | - | pF |
| R_G | Intrinsic gate resistance | $f = 1\text{ MHz}$, $I_D = 0\text{ A}$ | - | 7 | - | Ω |
| Q_g | Total gate charge | $V_{DD} = 480\text{ V}$, $I_D = 11\text{ A}$, $V_{GS} = 10\text{ V}$ (see Figure 15: "Gate charge test circuit") | - | 17 | - | nC |
| Q_{gs} | Gate-source charge | | - | 3.1 | - | nC |
| Q_{gd} | Gate-drain charge | | - | 7.3 | - | nC |

Notes:

⁽¹⁾ $C_{oss\text{ eq.}}$ is defined as a constant equivalent capacitance giving the same charging time as C_{oss} when V_{DS} increases from 0 to 80% V_{DSS}

Table 7: Switching energy

| Symbol | Parameter | Test conditions | Min. | Typ. | Max. | Unit |
|-------------|---|--|------|------|------|---------------|
| $E_{(off)}$ | Turn-off energy (from 90% V_{GS} to 0% I_D) | $V_{DD} = 400\text{ V}$, $I_D = 1.5\text{ A}$ $R_G = 4.7\text{ }\Omega$, $V_{GS} = 10\text{ V}$ | - | 4.7 | - | μJ |
| | | $V_{DD} = 400\text{ V}$, $I_D = 3.5\text{ A}$ $R_G = 4.7\text{ }\Omega$, $V_{GS} = 10\text{ V}$ | - | 5.2 | - | μJ |

Table 8: Switching times

| Symbol | Parameter | Test conditions | Min. | Typ. | Max. | Unit |
|--------------|---------------------|---|------|------|------|------|
| $t_{d(on)}$ | Turn-on delay time | $V_{DD} = 300\text{ V}$, $I_D = 5.5\text{ A}$, $R_G = 4.7\ \Omega$, $V_{GS} = 10\text{ V}$ (see Figure 14: "Switching times test circuit for resistive load" and Figure 19: "Switching time waveform") | - | 11 | - | ns |
| t_r | Rise time | | - | 10 | - | ns |
| $t_{d(off)}$ | Turn-off delay time | | - | 40 | - | ns |
| t_f | Fall time | | - | 15 | - | ns |

Table 9: Source drain diode

| Symbol | Parameter | Test conditions | Min. | Typ. | Max. | Unit |
|-----------------|-------------------------------|--|------|------|------|---------------|
| I_{SD} | Source-drain current | | - | | 11 | A |
| $I_{SDM}^{(1)}$ | Source-drain current (pulsed) | | - | | 44 | A |
| $V_{SD}^{(2)}$ | Forward on voltage | $V_{GS} = 0\text{ V}$, $I_{SD} = 11\text{ A}$ | - | | 1.6 | V |
| t_{rr} | Reverse recovery time | $I_{SD} = 11\text{ A}$, $di/dt = 100\text{ A}/\mu\text{s}$, $V_{DD} = 60\text{ V}$ (see Figure 16: "Test circuit for inductive load switching and diode recovery times") | - | 280 | | ns |
| Q_{rr} | Reverse recovery charge | | - | 2.7 | | μC |
| I_{RRM} | Reverse recovery current | | - | 19.5 | | A |
| t_{rr} | Reverse recovery time | $I_{SD} = 11\text{ A}$, $di/dt = 100\text{ A}/\mu\text{s}$, $V_{DD} = 60\text{ V}$, $T_j = 150\text{ }^\circ\text{C}$ (see Figure 16: "Test circuit for inductive load switching and diode recovery times") | - | 400 | | ns |
| Q_{rr} | Reverse recovery charge | | - | 3.8 | | μC |
| I_{RRM} | Reverse recovery current | | - | 19 | | A |

Notes:

(1)Pulse width is limited by safe operating area

(2)Pulsed: pulse duration = 300 μs , duty cycle 1.5%

2.2 Electrical characteristics (curves)

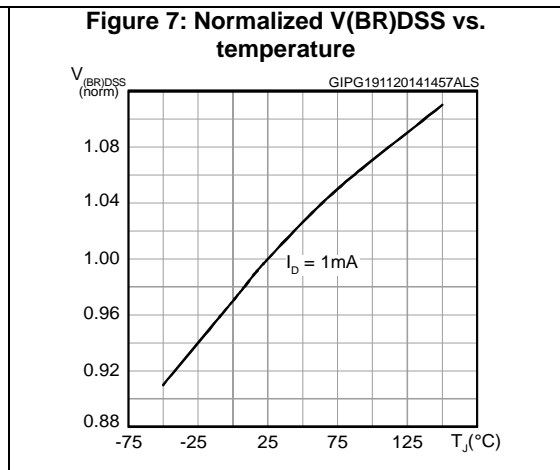
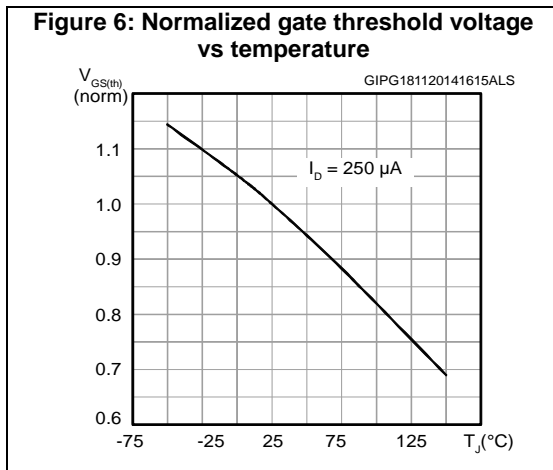
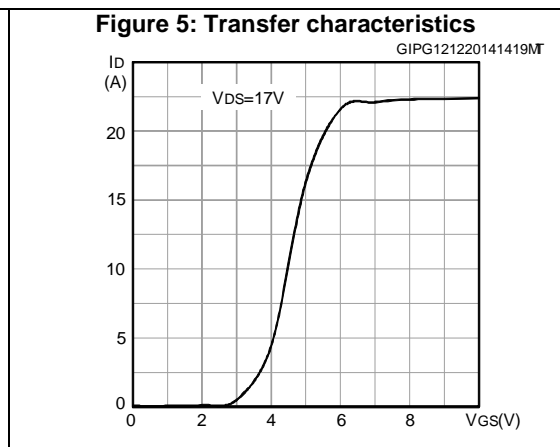
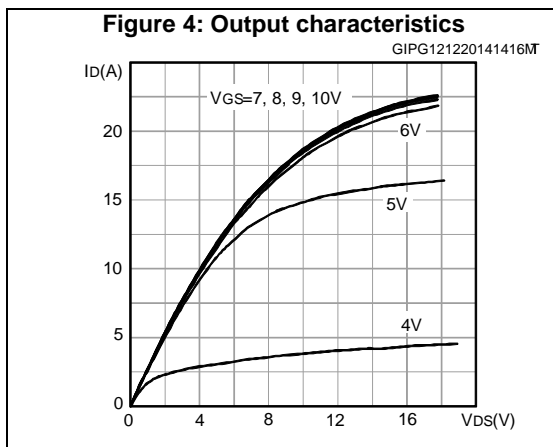
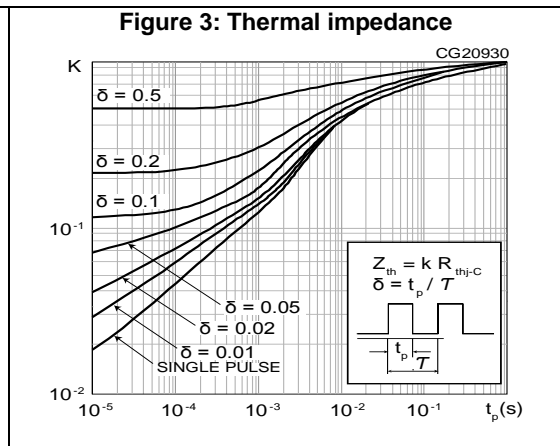
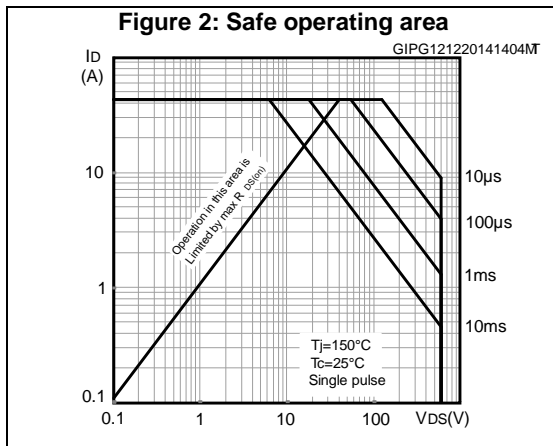

Figure 8: Static drain-source on-resistance

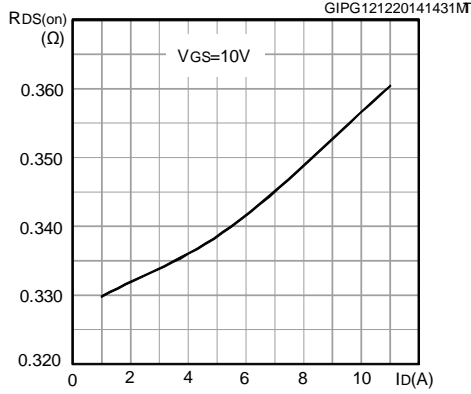

Figure 9: Normalized on-resistance vs temperature

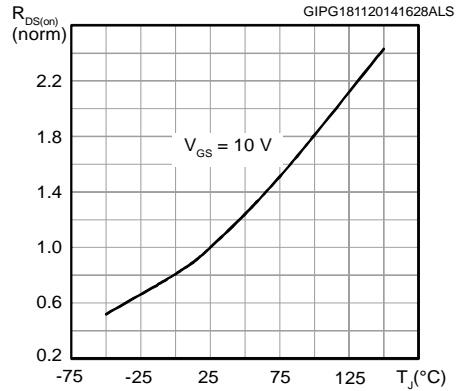

Figure 10: Gate charge vs. gate-source voltage

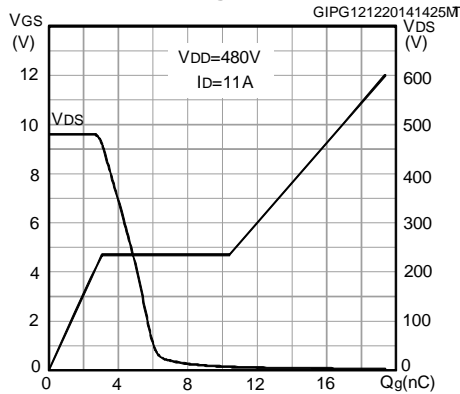

Figure 11: Capacitance variations

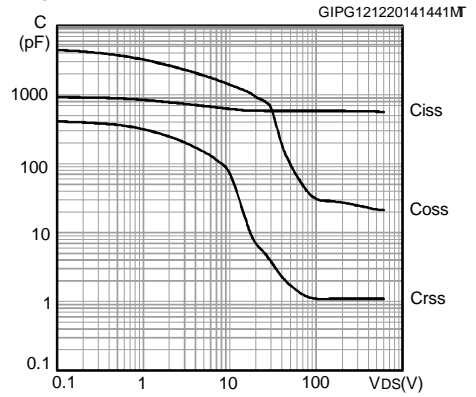

Figure 12: Turn-off switching loss vs drain current

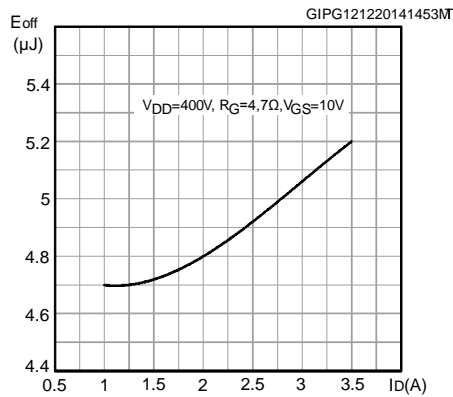
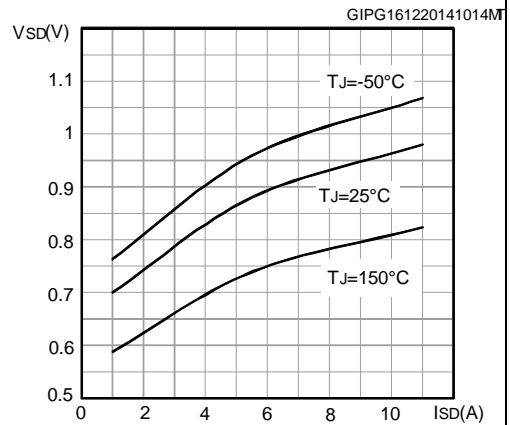
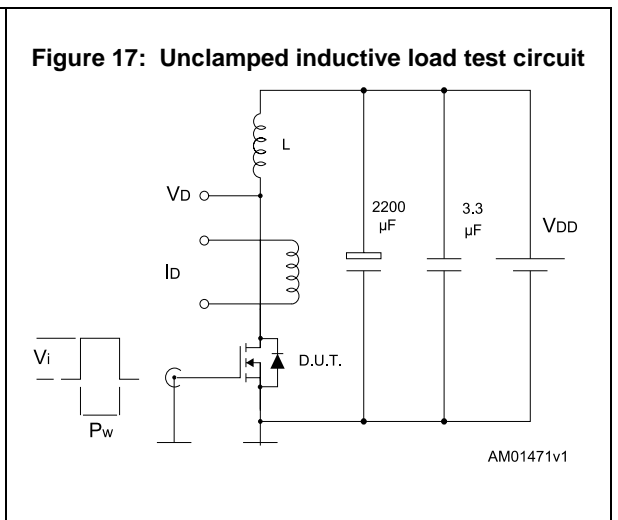
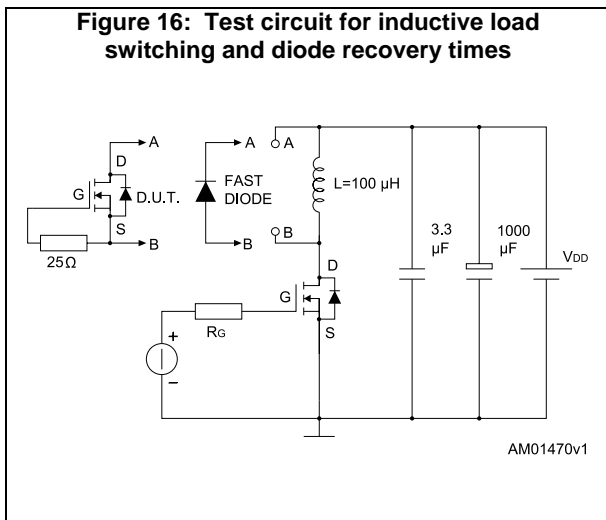
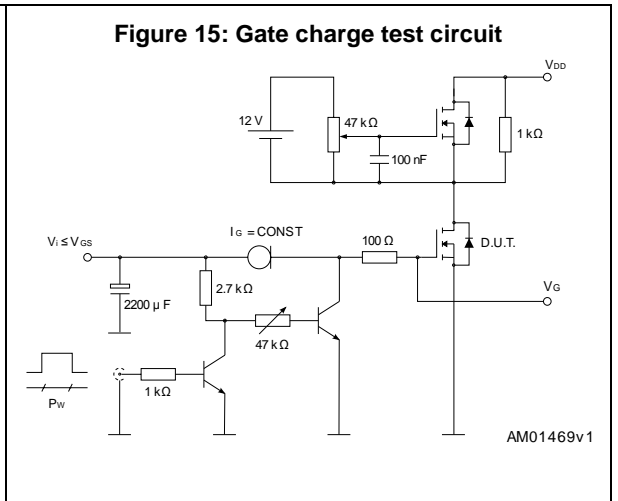
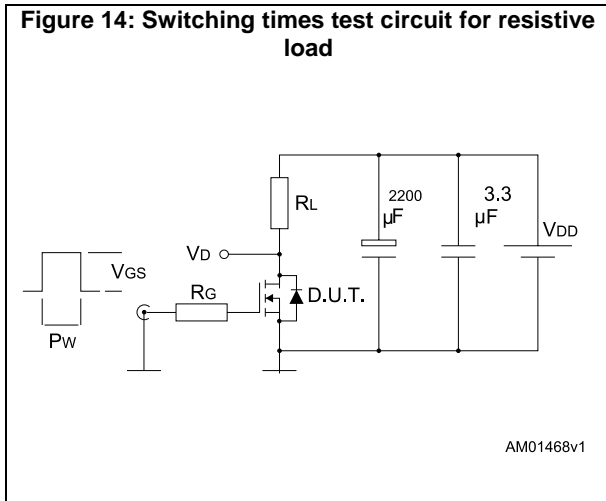
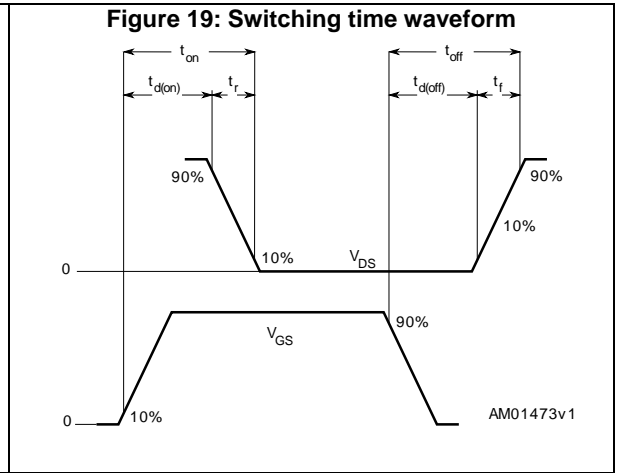
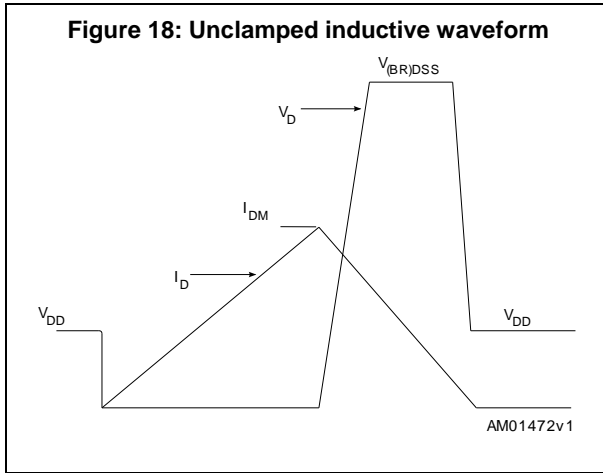

Figure 13: Source-drain diode forward characteristic



3 Test circuits





4 Package mechanical data

In order to meet environmental requirements, ST offers these devices in different grades of ECOPACK® packages, depending on their level of environmental compliance. ECOPACK® specifications, grade definitions and product status are available at: www.st.com. ECOPACK® is an ST trademark.

4.1 TO-220 type A package information

Figure 20: TO-220 type A package outline

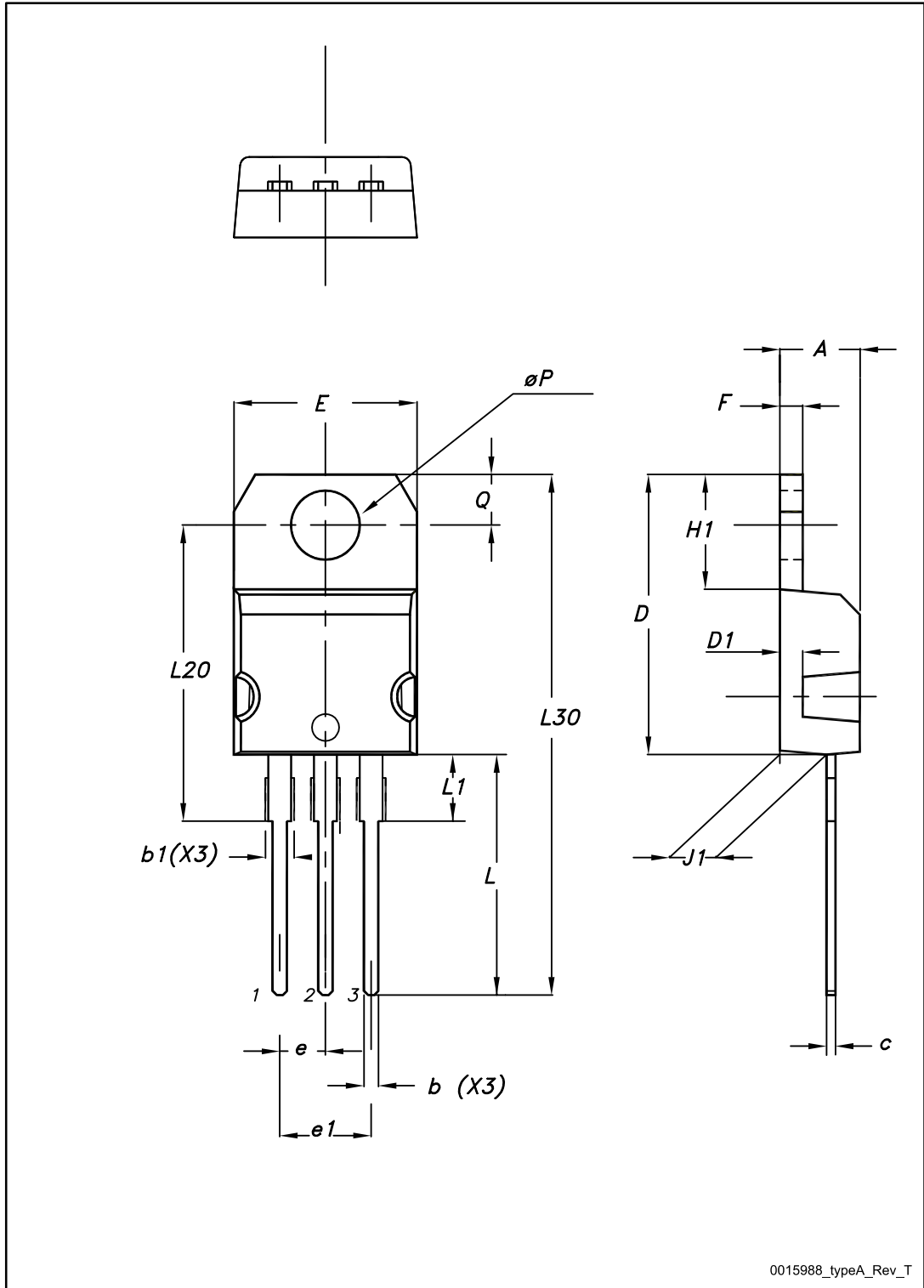

Table 10: TO-220 type A mechanical data

| Dim. | mm | | |
|------|-------|-------|-------|
| | Min. | Typ. | Max. |
| A | 4.40 | | 4.60 |
| b | 0.61 | | 0.88 |
| b1 | 1.14 | | 1.70 |
| c | 0.48 | | 0.70 |
| D | 15.25 | | 15.75 |
| D1 | | 1.27 | |
| E | 10 | | 10.40 |
| e | 2.40 | | 2.70 |
| e1 | 4.95 | | 5.15 |
| F | 1.23 | | 1.32 |
| H1 | 6.20 | | 6.60 |
| J1 | 2.40 | | 2.72 |
| L | 13 | | 14 |
| L1 | 3.50 | | 3.93 |
| L20 | | 16.40 | |
| L30 | | 28.90 | |
| øP | 3.75 | | 3.85 |
| Q | 2.65 | | 2.95 |

5 Revision history

Table 11: Document revision history

| Date | Revision | Changes |
|-------------|----------|---|
| 15-Dec-2014 | 1 | First release. |
| 18-Dec-2014 | 2 | Document status promoted from preliminary data to production data. Updated Table 6: "Dynamic" . Minor text changes. |

IMPORTANT NOTICE – PLEASE READ CAREFULLY

STMicroelectronics NV and its subsidiaries ("ST") reserve the right to make changes, corrections, enhancements, modifications, and improvements to ST products and/or to this document at any time without notice. Purchasers should obtain the latest relevant information on ST products before placing orders. ST products are sold pursuant to ST's terms and conditions of sale in place at the time of order acknowledgement.

Purchasers are solely responsible for the choice, selection, and use of ST products and ST assumes no liability for application assistance or the design of Purchasers' products.

No license, express or implied, to any intellectual property right is granted by ST herein.

Resale of ST products with provisions different from the information set forth herein shall void any warranty granted by ST for such product.

ST and the ST logo are trademarks of ST. All other product or service names are the property of their respective owners.

Information in this document supersedes and replaces information previously supplied in any prior versions of this document.

© 2014 STMicroelectronics – All rights reserved