

SERIES S0402

Hi-Rel Surface Mount Chip Inductors

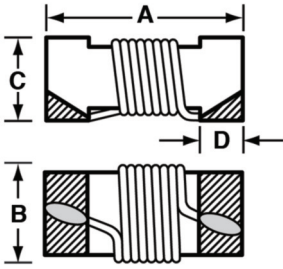

← Actual Size (Max.)

Physical Parameters

	Inches	Millimeters
A	0.037 - 0.043	0.940 - 1.092
B	0.018 - 0.025	0.457 - 0.635
C	0.030 Max.	0.762 Max.
D	0.006 - 0.010	0.152 - 0.254

Operating Temperature Range -55°C to +125°C

Current Rating at 90°C Ambient +35°C Rise

Insulation Resistance at 100 Vdc 1000 Mohm Min.

Dielectric Withstanding Voltage (DWV) 200 Vrms.

Core Material / Termination

Al₂O₃ / Sintered MoMn / Electroplated Ni / Electroplated Au Finish (RoHS)

- Termination Options:
1. Au Finish (RoHS)
 2. SnPb Solder
 3. Pb Free Solder (RoHS)

Electrical Characteristics Measured at +25°C

DASH NUMBER*	INDUCTANCE (nH) ±5%	Q MINIMUM	INDUCTANCE & Q TEST FREQUENCY (MHz)	SRF MINIMUM (MHz)	DC RESISTANCE MAXIMUM (OHMS)	CURRENT RATING MAXIMUM (mA)
--------------	---------------------	-----------	-------------------------------------	-------------------	------------------------------	-----------------------------

SERIES S0402						
-2N2J	2.2	18	250	8500	0.090	950
-3N3J	3.3	18	250	7000	0.080	800
-4N7J	4.7	14	250	4700	0.150	600
-6N8J	6.8	19	250	4800	0.100	600
-8N2J	8.2	20	250	4400	0.130	600
-10NJ	10.0	20	250	3900	0.210	475
-12NJ	12.0	21	250	3600	0.220	475
-15NJ	15.0	23	250	3280	0.220	475
-22NJ	22.0	24	250	2800	0.350	400
-27NJ	27.0	23	250	2480	0.360	400
-33NJ	33.0	23	250	2350	0.370	400
-47NJ	47.0	19	250	2100	0.830	150
-56NJ	56.0	21	250	1700	1.000	100
-68NJ	68.0	20	250	1620	1.180	100

Inductance Tolerance Options J (± 5%), H (± 3%), G (± 2%), F (± 1%)

S0402 Test Plan Advantages

- Provides multiple screening alternatives
- Eliminates necessity for SCD's
- Provides quicker delivery
- Reduces overall costs

Manufactured in Cleanroom

- ISO 7 (@0.5 micron) Air Cleanliness Classification
- Room Pressurization
- Air Change Rate
- HEPA Filter Leak Testing

How To Order:

S0402	8N2	G	2	S	(A) Inductor Series
(A)	(B)	(C)	(D)	(E)	(B) Inductance Value
					(C) Inductance Tolerance
					(D) Termination Finish
					(E) Test Plan Screening

S0402 Test Plan Options

Ordering Option Code		S	C	B	D	E	Y
Screening Level		MIL-STD-981 Class "S"	MIL-STD-981 Class "S" Modified	MIL-STD-981 Class "B"	MIL-STD-981 Class "B" Modified	High Temp	Commercial
Test	Method						
Thermal Shock	MIL-PRF-83446	25 Cycles 1/ (-55°C to +125°C)	25 Cycles (-55°C to +125°C)	25 Cycles 1/ (-55°C to +125°C)	25 Cycles (-55°C to +125°C)	5 Cycles (-55°C to +175°C)	
No-Load Burn-In	MIL-STD-981	125°C (96 hours)	125°C (96 hours)	125°C (96 hours)	125°C (96 hours)	200°C (96 hours)	
Dielectric Withstanding Voltage	MIL-PRF-83446	200 Vrms		200 Vrms			
Insulation Resistance	MIL-PRF-83446	1000 Mohms		1000 Mohms			
Electrical Characteristics: L, Q, DCR, SRF	MIL-PRF-83446	•	•	•	•	•	•
Radiographic Inspection	MIL-STD-981	•					
Visual & Dimensional Examination (external)	MIL-PRF-83446	•	•	•	•	•	•
* Electrical Characteristics (initial): L, Q, DCR, SRF	MIL-PRF-83446	•	•				
* Low Temperature Operation	MIL-PRF-83446	•	•				
* Temperature Rise	MIL-PRF-83446	•				•	
* Overload	MIL-PRF-83446	•	•			•	
* Moisture Resistance	MIL-PRF-83446	•					
* Electrical Characteristics: L and Q	MIL-PRF-83446	•	•				
* High Temperature Exposure	MIL-PRF-83446	•	•				
* Electrical Characteristics (final)	MIL-PRF-83446	•	•				
* Bond Strength	MIL-PRF-83446	•	•				
* Visual & Mechanical Examination (external)	MIL-PRF-83446	•	•				
* Visual & Mechanical Examination (internal)	MIL-STD-981	•					
* Solderability	MIL-PRF-83446	•	•				
* Electrical Characteristics (initial): L, Q, DCR, SRF	MIL-PRF-83446	•	•				
* Life	MIL-PRF-83446	2000 Hours (90°C Ambient)	500 Hours (90°C Ambient)			500 Hours (175°C Ambient)	
* Dielectric Withstanding Voltage	MIL-PRF-83446	80 Vrms	80 Vrms				
* Insulation Resistance	MIL-PRF-83446	1000 Mohms	1000 Mohms				
* Electrical Characteristics (final): L, Q, DCR, SRF	MIL-PRF-83446	•	•				
* Visual & Mechanical Examination (external)	MIL-PRF-83446	•	•				
Mechanical Shock/Vibration	MIL-STD-883					•	

*Destructive Test Units Required

1/ Continually monitor continuity during the entire final cycle to verify no intermittent conditions.

SERIES S0402

Hi-Rel Surface Mount
Chip Inductors

Suggested Land Patterns

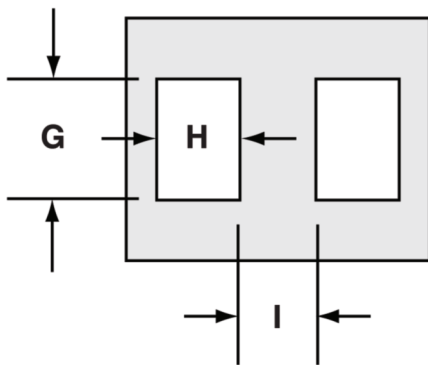

Delevan Series	G		H		I	
	Inches	mm	Inches	mm	Inches	mm
S0402 Series	0.026	0.660	0.014	0.356	0.018	0.457



S-Parameters (Typical)

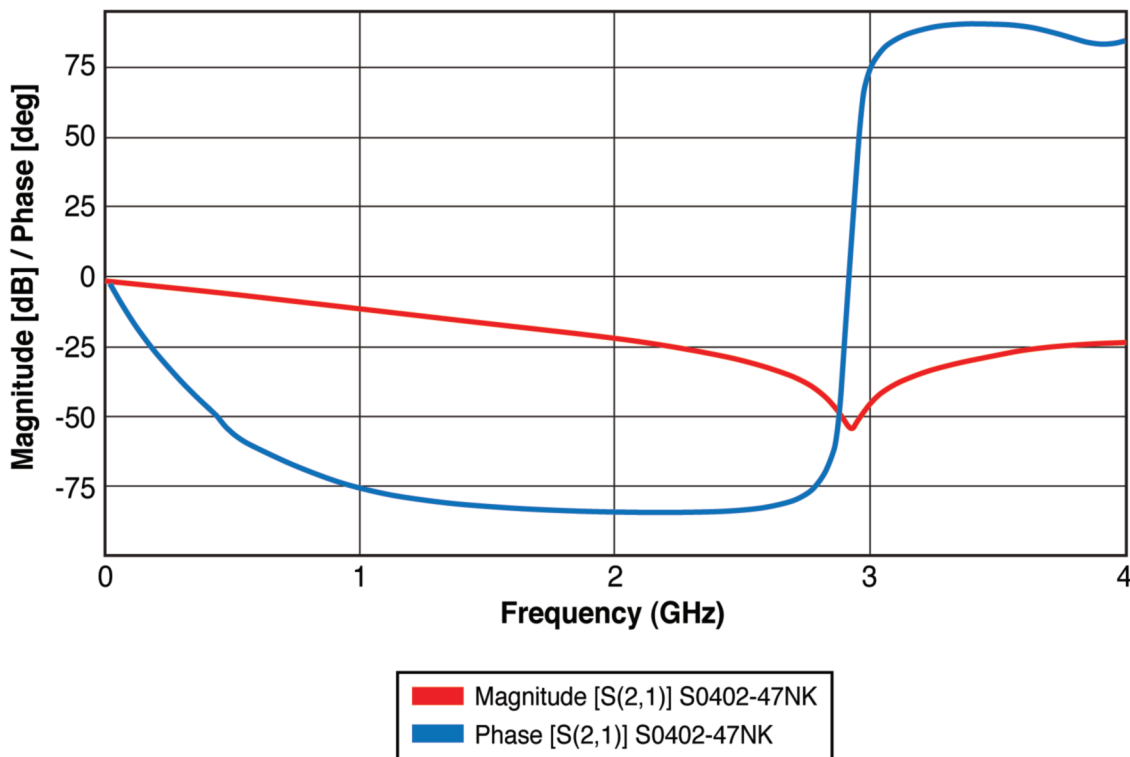

All product specifications and data contained herein are subject to change without notice to improve reliability, function, performance, design or otherwise.

