

DESCRIPTION

The IF-D98 is a very high-speed photologic detector housed in a “connector-less” style plastic fiber optic package. The detector contains an IC with a photodiode, linear amplifier and Schmitt trigger featuring an PECL logic compatible totem-pole output. Optical response of the IF-D98 extends from 400 to 1050 nm, making it compatible with a wide range of visible and IR LED and laser diode sources. The detector package features an internal micro-lens and a precision-molded PBT housing to ensure efficient optical coupling with standard 1000 μm core plastic fiber cable.

APPLICATION HIGHLIGHTS

The fast transition times of the IF-D98 make it suitable for high-speed digital data links. Link distances in excess of 75 meters at data rates of 155 Mbps are possible using standard 1000 μm core plastic fiber and an IF-E99 LED. The integrated design of the IF-D98 provides simple, cost-effective implementation in a variety of digital applications.

APPLICATIONS

- PC-to-Peripheral Data Links
- Motor Controller Triggering
- Ethernet LANs
- Medical Instruments
- Automotive Electronics
- Digitized Video and HDTV
- Sonet/SDH Receivers
- Robotics Communications
- Isolation from Lightning and Voltage Transients

FEATURES

- ◆ No Optical Design Required
- ◆ Mates with Standard 1000 μm Core, 2.2 mm Jacketed Plastic Fiber Cable
- ◆ Mates with 2.2 mm Jacketed Multimode Glass Fiber, 200/230 or 400/430 using Active Device Adapter – 51 0537; 51 0538
- ◆ Internal Micro-Lens for Efficient Coupling
- ◆ Inexpensive Plastic Connector Housing
- ◆ Connector-Less Fiber Termination and Connection
- ◆ Interference-Free Transmission from Light-Tight Housing
- ◆ Totem-Pole Output

MAXIMUM RATINGS

(T_A =25°C)

Operating Temperature Range
(T_{OP})-20° to 70°C

Storage Temperature Range
(T_{STG})-40° to 85°C

Soldering Temperature
(2mm from case bottom)
(T_S) t ≤ 5 s.....240°C

Supply Voltage, (V_S)..... -5 to 7 V

Power Dissipation
(P_{TOT}) T_A=25°C250 mW

De-rate Above 25°C1.7 mW/°C

CHARACTERISTICS (T_A =25°C)

| Parameter | Symbol | Min. | Typ. | Max. | Unit |
|--|---------------------------------|------|------------|------|-----------|
| Peak Sensitivity | λ _{PEAK} | - | 800 | - | nm |
| Spectral Bandwidth (S=10% of S _{MAX}) | Δλ | 400 | - | 1050 | nm |
| Operating Voltage | V _{CC} | 4.75 | 5 | 5.25 | V |
| Supply Current | I _{CC} | - | - | 40 | mA |
| Light Required to Trigger ^{1,2,3,4,5} (V _{CC} =5 V, λ=660 nm) | E _r (+) | - | 6.3 -22 | - | μW dBm |
| High Level Output Voltage ^{1,2,5} (I _{OH} = -1 mA) | V _{OH} | 3.9 | - | 4.3 | V |
| Low Level Output Voltage ^{1,2,5} (I _{OH} = -0.5 mA) | V _{OL} | 2.9 | - | 3.4 | V |
| Output Rise and Fall Times ^{1,2,5} | t _r , t _f | - | - | 3 | ns |
| Data Rate ^{6,7} | f _D | 4 | - | 156 | Mbps |
| Pulse Width Distortion | Δt | -3 | - | 3 | ns |
| Jitter | Δt _j | - | - | 3 | ns |

NOTES:

1. Input signal at 156 Mbps (Bi-phase signal)
2. 3 pF capacitor as load (including parasitic capacitance such as probes, connectors, and PCB patterns)
3. Optical input waveform is generated with IF-E99 LED
4. Average value, measured using plastic fiber (MH4001 by Mitsubishi Rayon)
5. 3 kΩ resistor externally connected to Q and Q̄
6. Bi-phase signal; NRZ conversion
7. With DC light, no light, and modulated light below 4 Mbps the high and low levels cannot be discerned.

CAUTION: The IF D98 is ESD sensitive. To minimize risk of damage observe appropriate precautions during handling and processing.

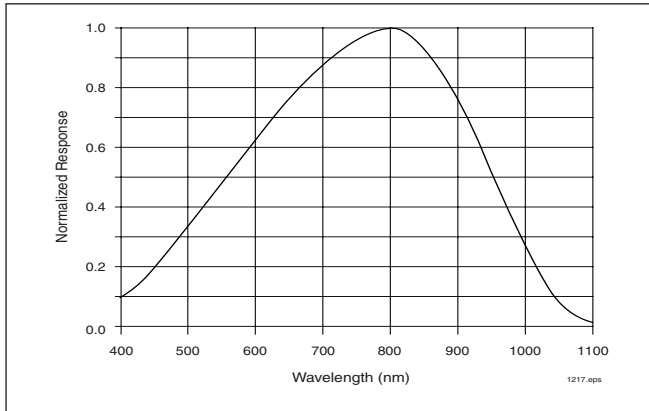

FIGURE 1. Normalized detector response versus wavelength.

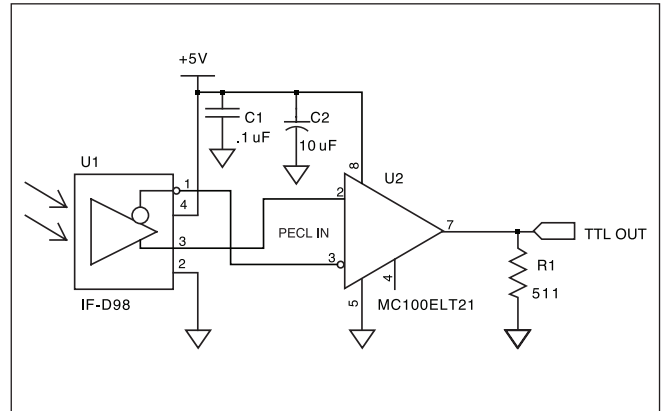

FIGURE 2. Typical interface circuit.

FIBER TERMINATION INSTRUCTIONS – PLASTIC OPTICAL FIBER

1. Cut off the ends of the optical fiber with a single-edge razor blade or sharp knife. Try to obtain a precise 90-degree angle (square).
2. Insert the fiber through the locking nut and into the connector until the core tip seats against the internal micro-lens.
3. Screw the connector locking nut down to a snug fit, locking the fiber in place. Do not exceed a torque of 0.4 N-m.

Glass fiber – Refer to instructions listed on manufacturer's data sheet for each active device adapter.

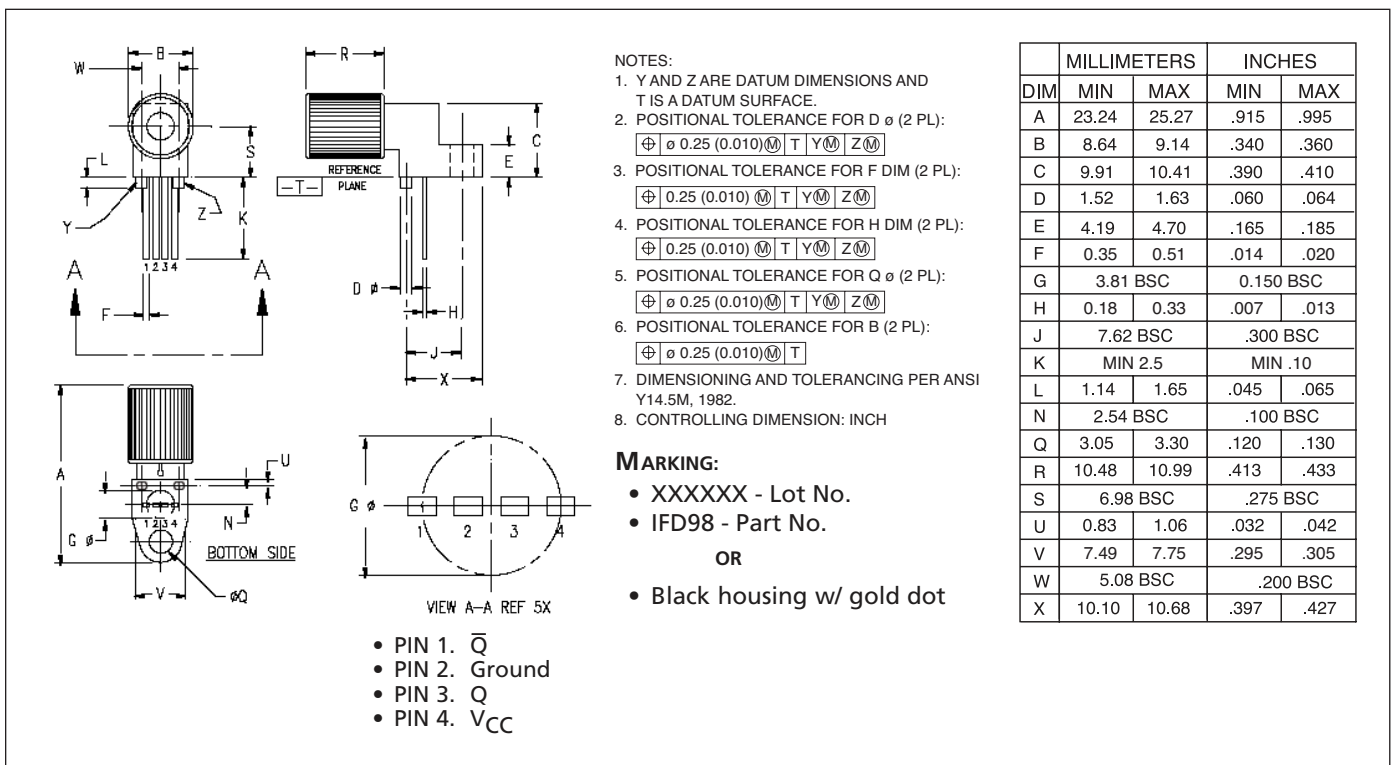

FIGURE 3. Case outline. Specifications are believed to be accurate but are subject to change. Industrial Fiber Optics assumes no responsibility for the consequences of using the information provided beyond replacement warranty for products not meeting stated specifications. Industrial Fiber Optics products are not authorized for use in life support applications without written approval from the President of Industrial Fiber Optics Corporation.

CAUTION:

- To avoid degraded device life due to package stress, do not bend or form leads outside the orientation shown on drawing.
- Ensure that solder flux does not migrate into the device and block the optical path, degrading the performance.
- If washing the device, liquid may become trapped in the part cavity. Ensure that all potentially corrosive materials are flushed out of the device.